

SABROE® PRODUCTS 2016

The big difference



SABROE® products are recognised and respected throughout the world for their build quality, long-term operating reliability and cost-effectiveness.

You – and your customers – also reap the benefits of our consistent focus on low life cycle costs and world-leading expertise in the use of naturally occurring refrigerants.



Contents

SABROE® products - the big difference	page 4
SABROE® compressors	page 10
SABROE® chillers	page 28
SABROE® heat pumps	page 42
SABROE® control systems	page 50
SABROE® End-of-Line Test Centre	page 72

Compressors

Chillers

Heat pumps

Control systems

The SABROE® brand has been in the business of industrial cooling and heating ever since 1897. We've proved we can repeatedly and consistently deliver on our customers' requirements – no matter how big and complex, or how small and straightforward.

We listen to what your real challenges are, and what you really want – and need. And then we focus well over a century of specialist knowledge on how best to achieve it.

Part of Johnson Controls

The SABROE® product brand is owned by Johnson Controls, a global diversified technology and industrial leader serving customers in more than 150 countries.



We are part of the Building Efficiency division of Johnson Controls, enabling us to provide SABROE® customers with a comprehensive range of products, systems and services for meeting heating, ventilating, air conditioning and refrigeration needs in industrial, commercial and residential buildings of all kinds.

SABROE® is a registered trade mark of Johnson Controls in the United States of America and other countries.

Other trade marks:
CMO™, SMC™, HPO™, HPC™, HPX™, TCMO™, TSMC™, SABflex®, SAB™, ChillPAC®, ComPAC™, PAC™, SABlight®, CAFP™, HeatPAC™, Unisab™, CP Optimiser™, ISAC™, AP1000™, iRIS™

SABROE® products – the big difference

The equipment you need – now and in the future

We provide the equipment you need to put thermal transfers to work in industrial and commercial installations – from a full spectrum of refrigeration compressors of all kinds to industrial chillers and heat pumps.

SABROE® systems are designed to be versatile and future-compatible, making it easy for you to repurpose, retrofit, expand and upgrade your installations and your thermal management capabilities, whenever the need arises.

Documented capabilities and performance

When you sign up for SABROE® solutions and equipment, we make sure you know exactly what you're getting. You don't just get average performance figures – you get exact, documented capabilities for your particular set-up, as tested at the state-of-the-art SABROE® test centre in Denmark, prior to delivery.

Full satisfaction – no surprises

We're committed to full transparency and helping our customers as much as possible. That's why we also use the same data and documentation in all subsequent SABROE® calculations about your set-up.

We document everything – and share the results with you and your staff, so there are no unwelcome surprises and you can put our specialist know-how to best possible use.

Know-how steers you away from risk

Reap the full potential of your equipment purchases

In the world of industrial refrigeration, the equipment you buy – whether standardised or individually customised – is just part of the overall picture.

You only reap the full potential of your equipment purchases when they are effectively integrated into your existing set-up and when all the operating parameters are fine-tuned to ensure you maximum cost-effectiveness.

Prevention is better than cure

With way over a century of heavyweight practical experience in everything even remotely related to industrial refrigeration compressors, SABROE® experts know pretty much all the on-site pitfalls, glitches and bottlenecks likely to occur.

This means that when you specify SABROE® equipment, you get more than you'd normally expect.

Our unique combination of market-leader expertise and first-mover technology capabilities means we know how to help prevent difficulties and downtime, rather than spending time and money dealing with them once they've cropped up.



Intelligent control opens up new opportunities

Cranking up practical value – boosting payback

Top-notch refrigeration set-ups depend heavily on the systems that control how they react to operating conditions and carry out their designated functions.

It's often the control systems that really determine the return on investment and practical, money-earning value.

Electronic advantages

SABROE® brings you the big benefits of world-leader expertise in all the nitty-gritty aspects of industrial refrigeration, seamlessly integrated from the same specialist manufacturer.

SABROE® electronic control and monitoring systems enable you to leverage the usefulness of your compressors, chillers and heat pumps, and to integrate them into industry-standard monitoring and control systems.

Information for better decisions

Data acquisition tells you exactly what's going on in your thermal transfer equipment and your primary processes – and enables you to match the work done to your exact needs at any given time.

Linking everything together

Seamlessly integrated, future-compatible control systems based on open architecture and industry-standard formats are crucial for the energy-efficient use of virtually all thermal transfer systems and equipment.

Better control means better results, and better results mean better return on investment.



The Unisab Event app enables you to keep tabs on everything going on in your refrigeration plant



Life cycle costs – an equation with many parts

Dealing with the real agendas

SABROE® experts have the practical experience to ask bang-on questions about what your company really needs. This often involves balancing lots of different parameters. That's why we can help you do the sums that give you the most cost-effective solution for your company's specific requirements.

Keeping costs down

The real cost of heating and cooling equipment stretches far beyond the purchase price, accumulating throughout its life cycle.

Everything about SABROE® compressors, chillers and heat pumps focuses on keeping your costs down – from delivery, commissioning and operations to service, retrofit and disposal.

From expenditure to benefits

The energy your system uses is the most important factor – by far – in determining your total cost of ownership. Even minor alterations in energy efficiency can mean a world of cost/benefit difference.

That's why SABROE® focuses on the complete picture – the life cycle costs (LCC) of your whole set-up – instead of just initial purchase costs.

This shifts your thermal transfer systems from being an expense to a benefit – with a visibly positive effect on operating costs, process effectiveness and final results.

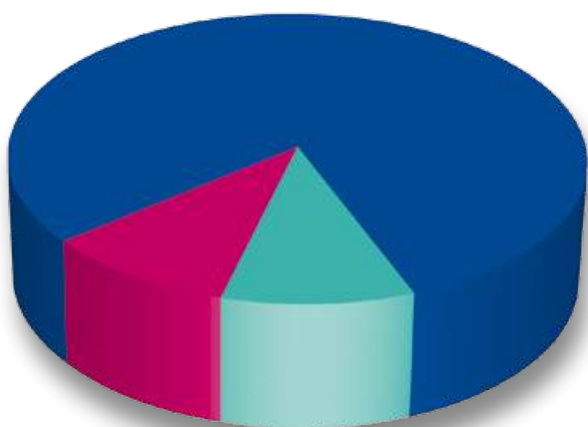

Operating costs

- Service costs
- Investment costs
- Energy costs

The advantages of using naturally occurring refrigerants

- Very energy-efficient
- No supply scarcity
- Low risk of prohibitive legislation or punitive duties
- Increasingly insisted upon throughout the industrial and consumer supply chain
- Available for virtually all kinds of industrial refrigeration.



Long service life saves you money

Tested to ensure reliability

SABROE® products and systems are renowned for exceptional reliability and technological advantages, backed by our ability to meet even the most demanding customer requirements.

One of the big advantages of doing business with SABROE® is that our compressor, chiller and heat pump products are all systematically tested before delivery. This ensures rapid, glitch-free commissioning and a bare minimum of interruption to your operations.

Industrial Refrigeration Parts Centre – global sourcing

The Industrial Refrigeration Parts Centre provides round-the-clock post-delivery support services that enable operators of SABROE® equipment to maximise return on investment and ensure the long-term stability of their operations.

Making the most of an effective worldwide logistics infrastructure and rapid-response inventory management, the Parts Centre dispatches any part to wherever in the world it may be needed, within just 24 hours (if the part is in stock).

Extensive specialist knowledge helps you

- identify minor malfunctions before they develop into major problems
- prevent unnecessary and expensive breakdowns
- cut operating costs by ensuring greater efficiency
- update your equipment and streamline your operating procedures
- extend the service life of your SABROE® equipment and installations.



AfterMarket Solutions (AMS)

Our AMS facility makes it supremely easy for you to source remanufactured compressor blocks to replace worn blocks, or have your own existing compressor blocks overhauled or repaired.

This facility is the overhaul, repair, re-manufacturing and stock centre for Johnson Controls industrial refrigeration companies throughout the world.

Screw or reciprocating compressor?

There is no simple answer to this constantly recurring question. Both technologies are viable alternatives for use in almost all installations, and both types are normally capable of doing the job.

Our sole aim is to make sure you get the best out of your particular set-up, and the best profit margins from your operations.

And to do that we can supply state-of-the-art compressors of both types, covering the full scope of normal capacities.

The criteria you have to balance normally include:

- Required capacity
- Operating conditions
- Available space
- Part-load requirements
- Temperature levels
- Energy consumption
- Choice of refrigerant
- Environmental concerns
- Maintenance issues
- Peak vs average ratio.

Variable-speed drive - only using what's needed

The vast majority of SABROE compressor models (both reciprocating and screw types) are available with variable-speed drive (VSD) to provide stepless control of your compressor capacity.

This helps you achieve maximum cooling effect using the minimum of energy, as well as keeping operating costs to the absolute minimum. The combination of a frequency converter, a VSD motor and the Unisab III integrated systems controller makes it possible to run the drive motor at speeds that match the load at any given time.

This enables you to reduce energy costs by as much as 30% compared with traditional fixed-speed compressors.



SABROE compressor programme

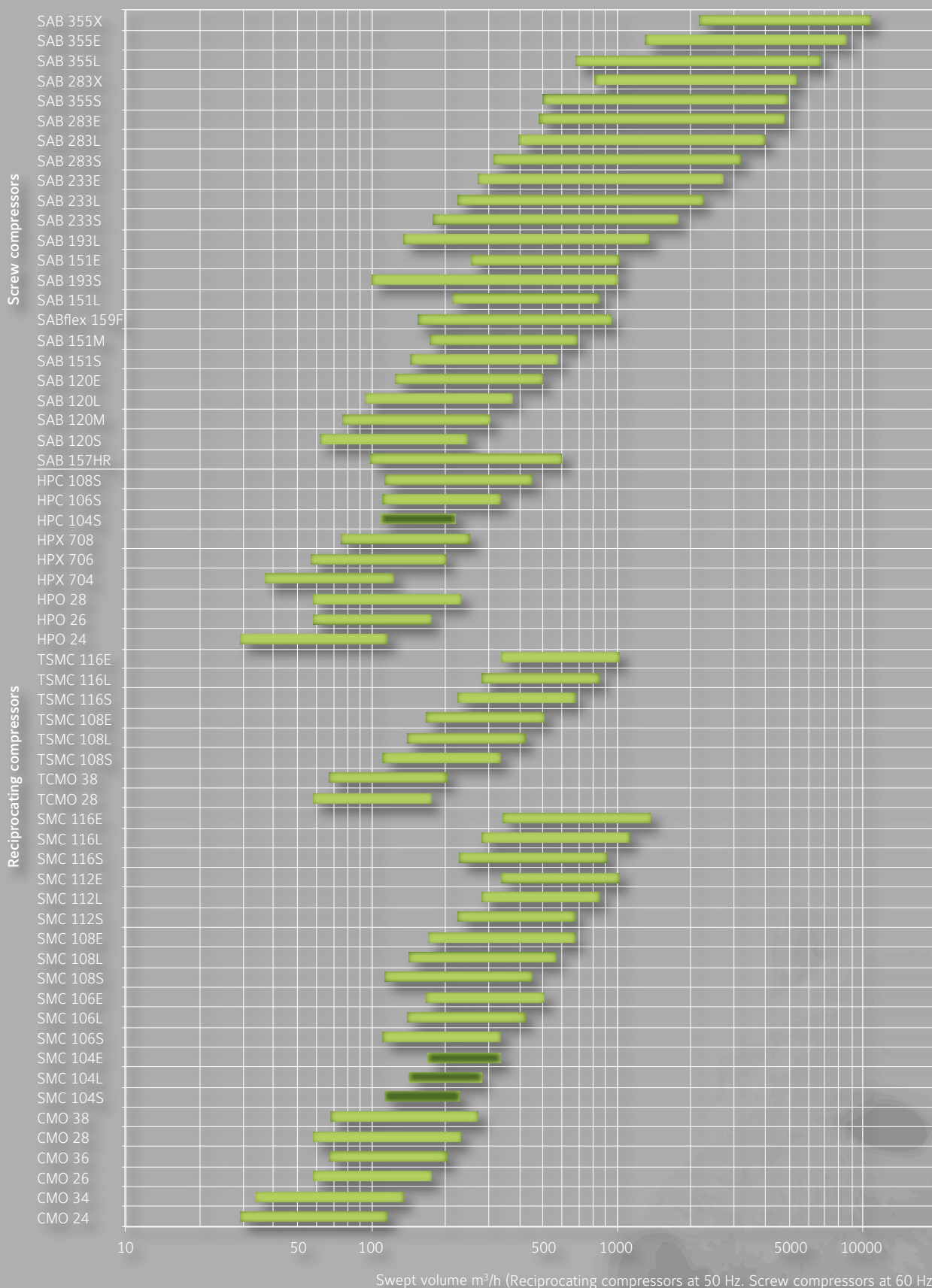

SABROE CMO™ reciprocating compressor units

Small single-stage compressors with swept volumes of 100–270 m³/h

CMO compressor units are small units specially designed for use in smaller-scale refrigeration installations where reliability is a particular concern, and uninterrupted service a big priority.

They are an economical, low-maintenance solution for smaller-scale, heavy-duty refrigeration installations, and are most commonly used as stand-alone units operating at full load, or as small back-up compressors.

Range

Six different models are available to provide swept volumes of between 97 and 273 m³/h.



CMO 24 reciprocating compressor unit with Unisab III systems controller

Advantages	Benefits
High coefficient of performance (COP), with excellent performance even under part-load conditions	Low power consumption, which greatly reduces operating costs
Special design ensures low noise and vibration	Wider range of possible mounting locations, and minimal expenditure on noise attenuation systems
Variable-speed drive (optional) provides stepless capacity control over the entire operating range	Power consumption and operating costs kept to a minimum
Repairs can be undertaken <i>in situ</i> , without removing the compressor	Lower repair costs and less downtime
Easy to access for service, with limited spare parts requirements	Easy, inexpensive maintenance, which helps limit downtime and reduce operating costs

Options

- Unisab III systems controller
- Variable-speed drive line (Unisab always included)
- Gauges, thermometers and temperature/pressure control switches
- Extended cylinder capacity control
- Oil level regulator (for use in parallel systems)
- ATEX-compliant configuration
- Oil separators with coalescing element
- Special vibration dampening.



CMO 28 reciprocating compressor block with gauges

Model	Number of cylinders	Swept volume at 1500 rpm m ³ /h	Swept volume at 1800 rpm m ³ /h	Nominal capacities in kW at 1500 rpm					Dimensions in mm			Weight excluding motor kg	Sound pressure level at 1500 rpm dB(A)
				R717		Booster -40/-10°C	R404A		L	W	H		
				Single/high stage -10/+35°C	0/+35°C		Single/high stage 0/+35°C	-10/+35°C					
CMO 24	4	97	116	53	85	14	85	54	1400-2150	800	900	480	69
CMO 26	6	146	175	79	127	21	127	81	1450-2175	800	900	520	71
CMO 28	8	194	233	105	170	28	169	108	1475-2200	800	900	550	72
CMO 34	4	113	136	62	100	17	99	63	1400-2150	800	900	480	70
CMO 36	6	170	204	93	149	25	149	95	1450-2175	800	900	520	72
CMO 38	8	228	273	123	199	33	198	127	1475-2200	800	900	550	73

Nominal capacities are based on 1500 rpm and 5K liquid subcooling.
 All refrigerants make it possible to operate CMO compressors at speeds of up to 1800 rpm.
 1500 rpm at 50 Hz.
 1800 rpm at 60 Hz or VSD.

Design pressure, HP side: 28 bar
 Design pressure, LP side: 18 bar

Sound pressure levels in free field, over reflecting plane and one metre distance from the unit.

All information is subject to change without notice.

SABROE SMC™ reciprocating compressor units

Large single-stage compressors with swept volumes of 200–1350 m³/h

SMC compressor units are ideal for use in medium-sized refrigeration installations where reliable service is a major priority. They are particularly effective under part-load conditions.

SABROE SMC compressors are world-renowned for their exceptional reliability, making them an economical, low-maintenance solution for heavy-duty refrigeration, using all common refrigerants.

Range

Fifteen different models are available to provide swept volumes of between 226 and 1357 m³/h.

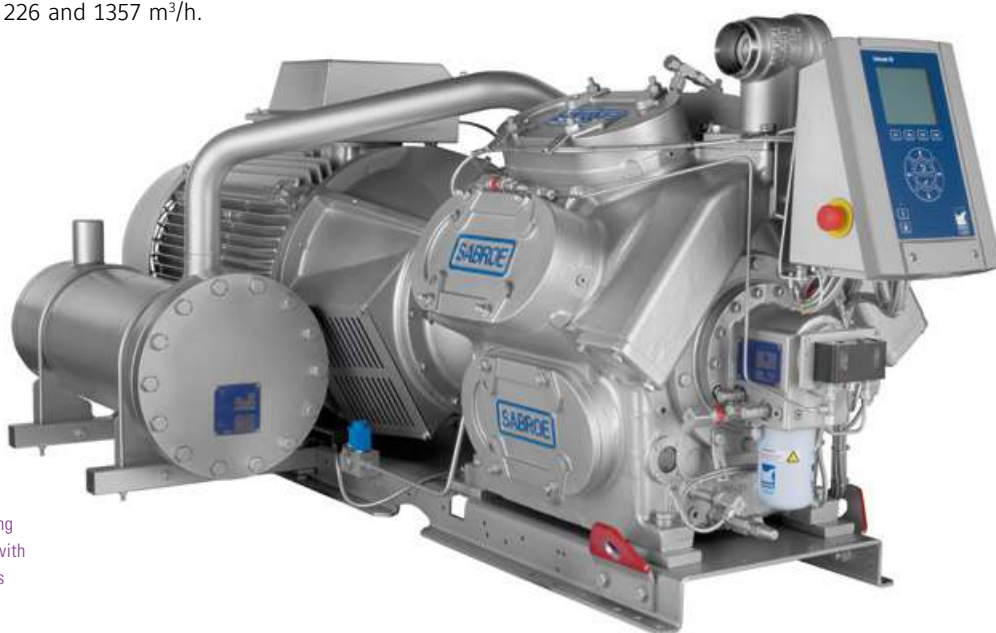

SMC 108 single-stage reciprocating compressor unit with Unisab III systems controller

Advantages

High coefficient of performance (COP), with excellent performance under part-load conditions

Variable-speed drive (optional) provides stepless capacity control over the entire operating range

Repairs can be undertaken *in situ*, without removing the compressor

Easy to access for service, with limited spare parts requirements

Special oil separator design based on coalescer technology

Benefits

Low power consumption, which greatly reduces operating costs

Power consumption and operating costs kept to a minimum

Lower repair costs and less downtime

Easy, inexpensive maintenance, which helps limit downtime and reduce operating costs

Low oil carry-over, which cuts back on oil costs

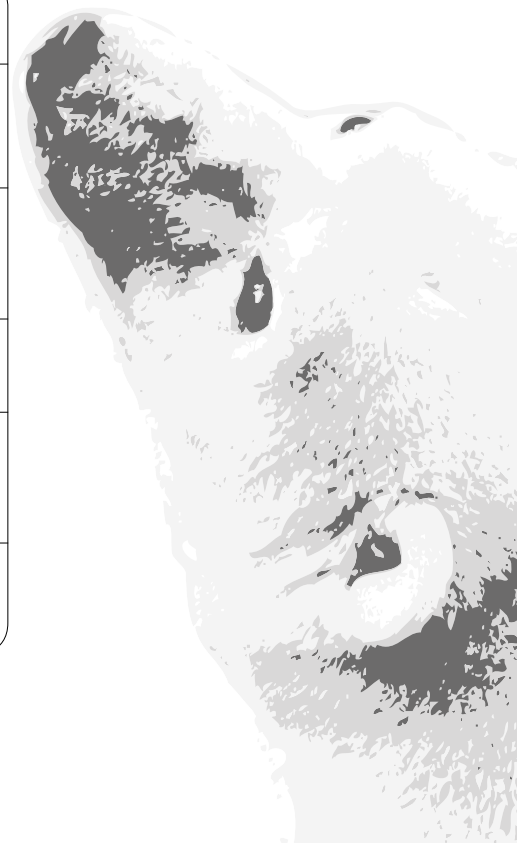

Options

- Unisab III systems controller
- Variable-speed drive line (Unisab always included)
- Gauges, thermometers and temperature/pressure control switches
- Extended cylinder capacity control
- Oil level regulator (for use in parallel systems)
- ATEX-compliant configuration
- Special vibration dampening.

To the left:
SMC 108 single-stage reciprocating compressor block with gauges



To the right:
SMC 112 single-stage reciprocating compressor block with Unisab III systems controller



Model	Number of cylinders	Swept volume at 1500 rpm m ³ /h	Swept volume at 1800 rpm m ³ /h	Nominal capacities in kW at 1500 rpm					Dimensions in mm			Weight excluding motor kg	Sound pressure level at 1500 rpm dB(A)
				R717		Booster -40/-10°C	R404A		L	W	H		
				Single/high stage -10/+35°C	0/+35°C		Single/high stage 0/+35°C	-10/+35°C					
SMC 104 S	4	226	271	129	209	35	205	132	2400-2800	1228	1103	830	80
SMC 104 L	4	283	339	167	266	46	208	235	2400-2800	1228	1103	830	81
SMC 104 E	4	339	N/A	206	324	57	N/A	N/A	2400-2800	1228	1103	830	81
SMC 106 S	6	339	407	194	313	52	308	197	2400-2800	1190	1108	925	81
SMC 106 L	6	424	509	251	398	70	312	202	2400-2800	1190	1108	925	82
SMC 106 E	6	509	N/A	309	486	86	N/A	N/A	2400-2800	1190	1108	925	82
SMC 108 S	8	453	543	259	417	70	410	263	2400-2800	1201	1103	990	82
SMC 108 L	8	566	679	335	531	93	416	270	2400-2800	1201	1103	990	83
SMC 108 E	8	679	N/A	412	648	115	N/A	N/A	2400-2800	1201	1103	990	83
SMC 112 S	12	679	814	388	626	106	616	395	2425-3000	1290	1314	1660	83
SMC 112 L	12	848	1018	502	796	140	624	405	2425-3000	1290	1314	1660	83
SMC 112 E	12	1018	N/A	618	972	172	N/A	N/A	2425-3000	1290	1314	1660	83
SMC 116 S	16	905	1086	517	834	141	821	526	2475-3200	1301	1314	1760	84
SMC 116 L	16	1131	1357	669	1062	187	831	539	2475-3200	1301	1314	1760	84
SMC 116 E	16	1357	N/A	824	1297	230	N/A	N/A	2475-3200	1301	1314	1760	84

Nominal capacities are based on 1500 rpm and 5K liquid subcooling.
1500 rpm at 50 Hz.

1800 rpm at 60 Hz or VSD.

Design pressure, HP side: 28 bar

Design pressure, LP side: 18 bar

Sound pressure levels in free field, over reflecting plane
and one metre distance from the unit.

Min./max. speed	R717	R404A
SMC S-series	500-1800 rpm	500-1800 rpm
SMC L-series	500-1800 rpm	500-1500 rpm
SMC E-series	500-1500 rpm	N/A

All information is
subject to change
without notice.

SABROE HPO™/HPC™/HPX™ high-pressure reciprocating compressor units

High-pressure hybrids of CMO and SMC reciprocating compressors, with swept volumes of 100–450 m³/h

The blocks of the compressor units in the HPO/HPC/HPX range are cast in high-strength ductile iron, making them particularly strong and capable of operating under exceptionally high pressures.

This results in condensing temperatures of up to 70°C, and makes HPO/HPC and HPX compressors (condensing temperatures up to 90°C) ideal for use in conjunction with heat pumps and hot water applications, and as an extra “supercharge” stage in traditional ammonia plants. The renowned SABROE high-pressure compressors are ideal for use with either ammonia or CO₂ as refrigerant.

Sabroe high-pressure compressors provide reliability and cost savings provide exceptional reliability and big savings on operating costs, because they are based on the high-volume CMO and SMC compressors, and they share the majority of castings and parts.

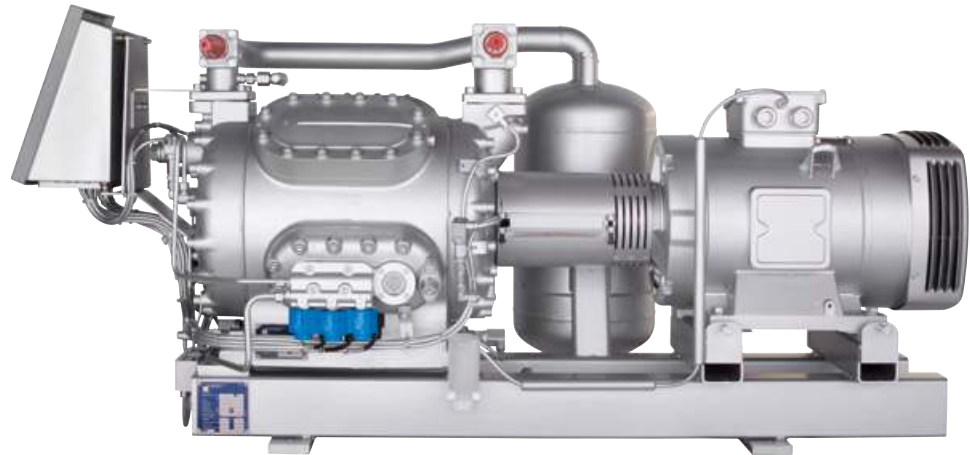

HPO 24 single-stage reciprocating compressor unit (50 bar) with Unisab III systems controller

Advantages	Benefits
High coefficient of performance (COP), with excellent performance under part-load conditions	Low power consumption, especially under part-load conditions. This greatly reduces operating costs
Variable-speed drive (optional) provides stepless capacity control over the entire operating range	Power consumption and operating costs kept to a minimum
Provides exceptionally high condensing temperatures – up to 70°C	Matches radiator temperature in most domestic/commercial heating systems, making HPO/HPC/HPX units ideal in district heating, etc
Designed for easy service access, and repairs can be undertaken <i>in situ</i> , without removing the compressor	Lower repair and maintenance costs, and less downtime
Special oil separator design based on coalescer technology	Low oil carry-over, which cuts back on oil costs

Range

Nine different models are available to provide swept volumes of between 97 and 452 m³/h.



HPC 108 single-stage reciprocating compressor block (40 bar) with Unisab III systems controller

Options

- Variable-speed drive line
- Gauges, thermometers and temperature/pressure control switches
- Extended cylinder capacity control
- ATEX-compliant configuration
- Special vibration dampening.

Model	Number of cylinders	Swept volume at 1500 rpm m ³ /h	Swept volume at 1800 rpm m ³ /h	Nominal capacities in kW at 1500 rpm (HPC) and 1800 rpm (HPO/HPX)					Dimensions in mm			Weight excluding motor kg	Sound pressure level at 1500 rpm dB(A)
				Heating	Cooling	Cooling	Cooling	Cooling	L	W	H		
				R717 +35/+72°C	R717 0/+55°C	R410A 0/+35°C	R744 -50/-10°C	R744 -40/-5°C					
HPO 24	4	97	116	267	71	117	92	138	1580-1930	835	985	510	74
HPO 26	6	146	175	397	106	176	138	207	1600-1950	940	985	550	76
HPO 28	8	194	233	529	141	235	184	276	1620-1970	940	985	580	77
HPC 104 S	4	226	N/A	629	168	284	228	338	2400-2800	1228	1103	850	81
HPC 106 S	6	339	N/A	942	252	426	343	507	2400-2800	1190	1108	1025	82
HPC 108 S	8	452	N/A	1256	335	568	457	676	2400-2800	1201	1103	1100	83
HPX 704	4	111	133	295*	92	N/A	124	185	2400-2800	1250	1100	850	84**
HPX 706	6	166	200	443*	138	N/A	185	275	2400-2800	1250	1100	1025	85**
HPX 708	8	222	266	590*	183	N/A	248	369	2400-2800	1250	1100	1100	86**

* HPX +35/+88°C

** Sound pressure level at HPX 1800rpm

For HPO

Design pressure, HP side: 50 bar

Design pressure, LP side: 26 bar

Differential pressure: 25 bar

For HPC

Design pressure, HP side: 40 bar

Design pressure, LP side: 26 bar

Differential pressure: 25 bar

For HPX

Design pressure, HP side: 60 bar

Design pressure, LP side: 26 bar

Differential pressure: 40 bar

Nominal capacities are based on max. 1500 rpm for HPC and 1800 rpm for HPO/HPX.

Nominal capacities for R744 are based on 0K subcooling in cascade cooler, 10K useful suction superheat.

Sound pressure levels in free field, over reflecting plane and one metre distance from the unit.

All information is subject to change without notice.

SABROE TCMO™/TSMC™ two-stage reciprocating compressor units

Two-stage versions of CMO and SMC reciprocating compressors, with swept volumes of 150–1000 m³/h

SABROE TCMO/TSMC two-stage reciprocating compressors are an economical operating alternative to single-stage compressors in smaller low-temperature refrigeration installations.

TCMO/TSMC compressor units are also ideal for medium-size industrial refrigeration installations that involve a big temperature range, such as freezer installations. Furthermore, these units are easy to customise with intermediate cooling systems.

Using a two-stage set-up built together as a single unit helps avoid equipment duplication – and thus reduce costs and save space.

Range

Eight different models are available to provide swept volumes of between 146 and 1018 m³/h.



TSMC 108 two-stage reciprocating compressor unit with intermediate cooling system and Unisab III systems controller

Advantages	Benefits
Splitting the temperature lift into two separate stages reduces overall energy consumption	Two-stage installations are relatively cost-effective, which helps reduce energy costs
Relatively small footprint	Can be installed in relatively small locations, or where space is limited
High coefficient of performance (COP), with excellent performance under part-load conditions	Low power consumption, which greatly reduces operating costs
Variable-speed drive (optional) provides stepless capacity control over the entire operating range	Power consumption and operating costs kept to a minimum

Options

- Unisab III systems controller
- Gauges, thermometers and temperature/pressure control switches
- Oil level regulator (for use in parallel systems)
- ATEX-compliant configuration
- Special vibration dampening.

Intermediate cooling systems (optional)

In plants with multiple two-stage compressors, TCMO/TSMC units can be connected to a shared intermediate cooler, in a separate installation.

Alternatively, a range of built-on intermediate cooling systems are available, as optional equipment.

- Injection inter-stage gas cooling without liquid sub-cooling
- Injection inter-stage gas cooling with liquid sub-cooling in a shell-and-tube heat exchanger
- Closed flash inter-stage cooling in a shell-and-coil intermediate cooler, with liquid sub-cooling in the coil.

Model	Number of cylinders low/high-pressure side	Swept volume at 1500 rpm m ³ /h	Swept volume at 1800 rpm m ³ /h	Nominal capacities in kW at 1500 rpm *) 1200 rpm				Dimensions in mm without intermediate cooler			Weight excluding motor kg	Sound pressure level at 1500 rpm dB(A)
				-40/+35°C				L	W	H		
				R717	R134a	R404A	R507					
TCMO 28	6 / 2	146	175	20	11	27	28	1400-1750	700	1000	500	71
TCMO 38	6 / 2	170	204	23	14	32	33	1400-1750	700	1000	500	71
TSMC 108 S	6 / 2	340	407	50	30	66	70	1900-2500	1050	1125	1000	82
TSMC 108 L	6 / 2	424	509	66	31 *	68 *	72 *	1900-2500	1050	1125	1000	83
TSMC 108 E	6 / 2	611	N/A	82	N/A	N/A	N/A	1900-2500	1050	1125	1000	83
TSMC 116 S	12 / 4	679	814	100	60	132	139	2475-3200	1150	1335	1800	84
TSMC 116 L	12 / 4	848	1018	133	62 *	136 *	144 *	2475-3200	1150	1335	1800	84
TSMC 116 E	12 / 4	1018	N/A	163	N/A	N/A	N/A	2475-3200	1150	1335	1800	84

Nominal capacities are at 1500 rpm except for * at 1200 rpm.

Nominal capacities are based on 2K subcooling from condenser, 2K superheat and liquid subcooling in intermediate cooler to 10°C above intermediate temperature.

1500 rpm at 50 Hz.

1800 rpm at 60 Hz or VSD.

For TCMO

Design pressure, HP side: 28 bar

Design pressure, LP side: 18 bar

For TSMC

Design pressure, HP side: 28 bar

Design pressure, LP side: 18 bar

Sound pressure levels in free field, over reflecting plane and one metre distance from the unit.

SABROE SABflex® screw compressor units

Small screw compressor units with swept volumes of 160–950 m³/h

SABROE SABflex screw compressors are specially designed for installations where the requirements for refrigeration capacity vary over time. These smaller-size units are optimised to ensure exceptional part-load performance as well as the best possible energy efficiency.

Everything about these units is configured for use with variable-speed drive (VSD), doing away with the traditional capacity slider and ensuring skip-free performance across the entire 1,000–6,000 rpm capacity range.

The VSD drive can be mounted on the unit, or separately in an appropriate switchboard room.

Range

SABflex units are available to provide swept volumes of 160–950 m³/h at 6000 rpm using a high-speed motor, or 160–570 m³/h at 3600 rpm using a standard motor.

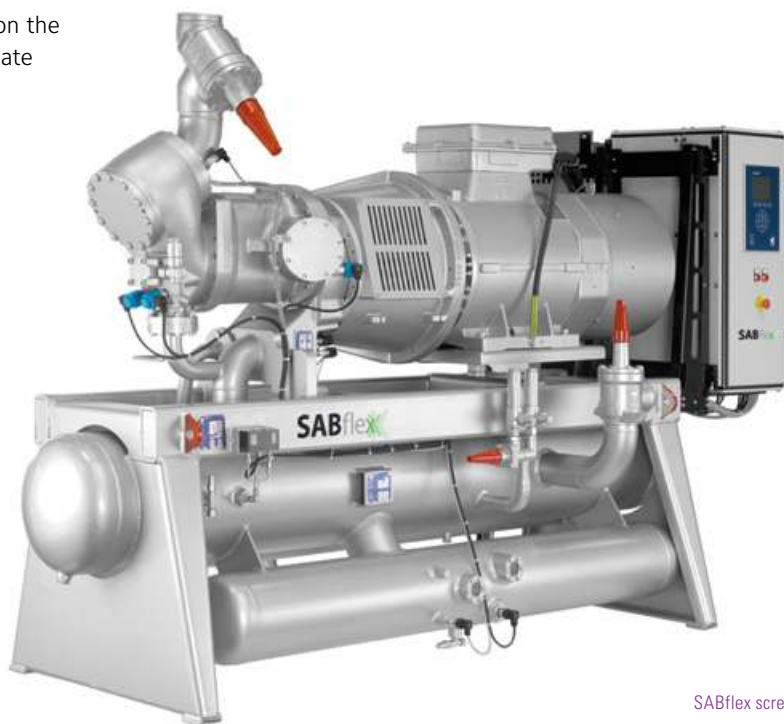

SABflex screw compressor unit

Advantages

Benefits

Stepless, skip-free capacity control ensures that output always matches requirements

Lowest possible operating costs and rapid return on investment

Consistently high performance at both full and part load

Maximum part-load efficiency and low life cycle costs

Uncomplicated design with fewer moving parts and very low vibration

Exceptional reliability and low maintenance costs

Supports Condition Based Service (CBS) schedules and the SABROE Block Swap Concept

Optimised service/maintenance intervals, and unscheduled downtime minimised

Standardised electrical panel and drive line, factory tested prior to delivery

Rapid commissioning and maximum in-service reliability

Options

- Thermosyphon and water-cooled oil coolers, with 3-way oil temperature control valve
- Complete economiser systems
- Demand oil pump – controlled by Unisab III systems controller.
- Dual Super-filter™ oil filters
- Complete economiser system.

Only for use with ammonia (R717) as refrigerant.

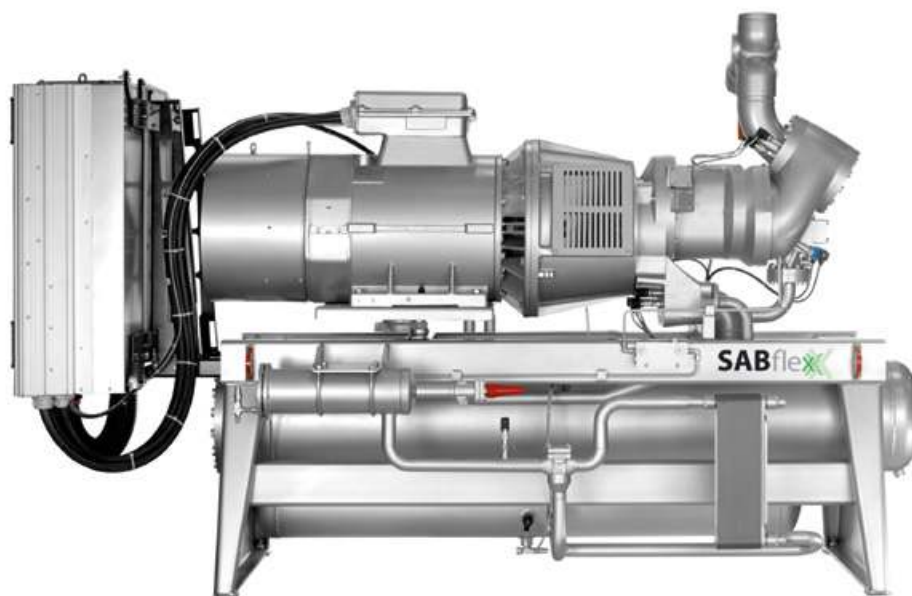

SABflex screw
compressor unit

Model	Swept volume m ³ /h	Nominal capacities in kW for R717			Dimensions in mm L x W x H	Weight excluding motor/oil kg	Sound pressure level dB(A)
		High stage -10/+35°C	Booster -40/-10°C	With economiser -40/+35°C			
SABflex at 3600 rpm	570	355	112	104	3250 x 1450 x 2100	2200	83
SABflex at 6000 rpm	950	592	187	173	3250 x 1450 x 2100	2200	89

Sound pressure levels in free field over reflecting plane and one metre distance from the unit.

All information is
subject to change
without notice.

SABROE SAB™ screw compressor units

Small single-stage compressors with swept volumes of 200–1000 m³/h

SABROE SAB screw compressors are designed and configured to tackle smaller-scale industrial refrigeration requirements where a combination of exceptional reliability, high performance and low operating costs is essential.

These small units can be used with all the most common refrigerants and process gases, and all the components are selected for good accessibility and ease of service, ensuring cost-effective maintenance.

Range

Eight different models are available to provide swept volumes of 204–1016 m³/h.

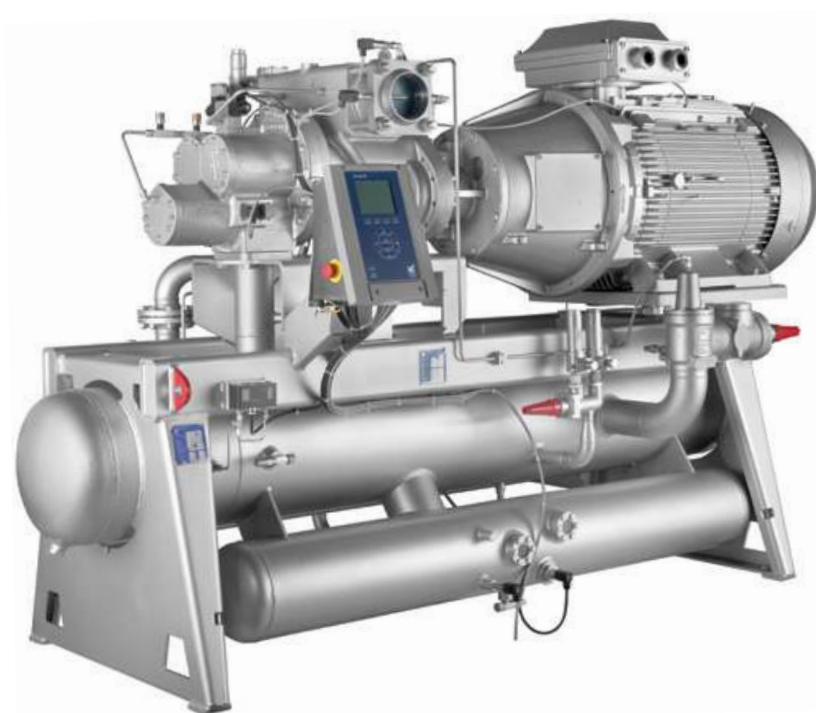

SAB 151 screw compressor unit with Unisab III systems controller

Advantages	Benefits
Variable-speed drive and stepless capacity control ensure that capacity is always adjusted to suit requirements	Maximum part-load efficiency and lowest possible operating costs
SAB screw compressor units are all equipped with a Unisab III systems controller	More efficient operating profile, less downtime and longer service life
Cold Start™ valve lubricates the compressor, with no oil pump needed	Lower operating costs and less maintenance
SuperFilter II™ oil filter captures 99 of all particles larger than 5 microns	Longer bearing life, providing maximum reliability and savings on both maintenance and replacement
Space-saving design with small footprint	Significant reductions in space requirements

Options

- Variable-speed drive
- Thermosyphon and water-cooled oil coolers, with 3-way oil temperature control valve
- Liquid injection oil cooling (EZ Cool™)
- Dual SuperFilter II™ oil filters (on SAB 151 models only)
- Complete economiser systems
- Demand oil pump – controlled by Unisab III systems controller
- Sensors and transmitters for control by external PLC systems.

Model	Swept volume at 3000 rpm* m ³ /h	Swept volume at 3600 rpm* m ³ /h	Nominal capacities in kW at 3000 rpm						Dimensions in mm L x W x H	Weight excluding motor/oil kg	Sound pressure level at 3000 rpm dB(A)
			R717		R404A		With economiser				
			High stage -10/+35°C	Booster -40/-10°C	High stage		R717 -40/+35°C	R404A			
SAB 120 S	204	245	121	36	115	157	36	47	2200 x 1300 x 1500	1200	85
SAB 120 M	255	306	156	48	152	207	47	63	2200 x 1300 x 1500	1200	86
SAB 120 L	316	379	200	61	195	265	61	80	2200 x 1300 x 1500	1300	88
SAB 120 E	413	496	270	83	261	355	82	107	2200 x 1300 x 1500	1300	89
SAB 151 S	484	581	305	97	305	416	87	126	3000 x 1450 x 1800	2050	90
SAB 151 M	571	685	369	117	367	500	105	151	3000 x 1450 x 1800	2050	91
SAB 151 L	708	850	469	149	466	635	133	192	3000 x 1450 x 1800	2050	91
SAB 151 E	847	1016	568	180	560	763	161	231	3000 x 1450 x 1800	2050	92

Nominal capacities are based on 3000 rpm.
3000 rpm at 50 Hz.
3600 rpm at 60 Hz or VSD.

*SAB 120 S for 4-pole motor:
1500 rpm at 50 Hz
1800 rpm at 60 Hz or VSD

Sound pressure levels in free field, over reflecting plane
and one metre distance from the unit.



SABROE SAB™ screw compressor units

Large single-stage compressors with swept volumes of 850–10900 m³/h

The bigger models of SABROE SAB screw compressors are specifically engineered to deal with larger-scale industrial refrigeration installations in which requirements prioritise exceptional reliability, high performance and low operating costs. All the components are designed and configured to ensure low maintenance costs as a result of good accessibility and ease of service.

Like their smaller counterparts, these large-capacity compressor units can be used with all common refrigerants and process gases.

Range

Thirteen different models are available to provide swept volumes of 838–10864 m³/h.



SAB 233 screw compressor unit with Unisab III systems controller

Advantages

Benefits

Variable-speed drive and stepless capacity control ensures that capacity is always adjusted to suit requirements

Maximum part-load efficiency and lowest possible operating costs

SAB screw compressor units are all equipped with a Unisab III systems controller

More efficient operating profile, less downtime and longer service life

Cold Start™ valve lubricates the compressor, with no oil pump needed

Lower operating costs and less maintenance

SuperFilter II™ oil filter captures 99% of all particles larger than 5 microns

Longer bearing life, providing maximum reliability and savings on both maintenance and replacement

Space-saving design with small footprint

Significant reductions in space requirements

Compact oil separator

Highly efficient oil carry-over as a result of two-stage separation

Options

- Variable-speed drive
- Thermosyphon and water-cooled oil coolers, with 3-way oil temperature control valve
- Liquid injection oil cooling (EZ Cool™)
- Dual external oil filters (SuperFilter II™ type)
- Complete economiser systems
- Demand oil pump – controlled by Unisab III systems controller
- Sensors and transmitters for control by external PLC systems.

Model	Swept volume at 3000 rpm m ³ /h	Swept volume at 3600 rpm m ³ /h	Swept volume at 4200 rpm m ³ /h	Nominal capacities in kW at 3000 rpm						Dimensions in mm L x W x H	Weight excluding motor/oil kg	Sound pressure level at 3000 rpm dB(A)
				R717		R404A		With economiser				
				High stage -10/+35°C	Booster -40/-10°C	High stage -10/+35°C	0/+40°C	R717 -40/+35°C	R404A			
SAB 193 S	848	1018	1188	541	164	524	779	155	213	3150 x 1500 x 1800	2700	84
SAB 193 L	1131	1358	1584	723	220	709	1041	207	289	3250 x 1500 x 1900	2800	84
SAB 233 S	1494	1792	2091	974	292	922	1404	271	379	3700 x 1700 x 2100	4600	86
SAB 233 L	1880	2257	2633	1220	366	1199	1760	340	492	3700 x 1800 x 2200	4750	86
SAB 233 E	2323	2788	3253	1520	456	1472	2191	424	606	3700 x 1800 x 2200	4800	86
SAB 283 S	2676	3211	3746	1767	530	1694	2544	500	707	3700 x 1800 x 2250	5500	88
SAB 283 L	3370	4044	4720	2215	664	2079	3190	627	874	4150 x 1900 x 2650	5850	88
SAB 283 E	4055	4865	5676	2667	800	2524	N/A	755	1064	4450 x 2100 x 2850	7650	88
SAB 355 S	4192	5031	5869	2785	836	2649	4033	786	1116	4550 x 2350 x 3500	10000	89
SAB 283 X	4580	5496	6412	3033	910	2832	N/A	844	1185	4600 x 2100 x 2850	8950	88
SAB 355 L	5716	6860	8003	3771	1131	3418	5459	1065	1457	4700 x 2350 x 3500	10000	89
SAB 355 E	7275	8730	10186	4793	1438	4300	6940	1354	1838	4850 x 2350 x 3500	10200	89
SAB 355 X	9180	11016	12852	N/A	1796	N/A	N/A	1681	2139	5000 x 2350 x 3500	10400	89

Nominal capacities are based on 3000 rpm.

3000 rpm at 50 Hz.

3600 rpm at 60 Hz or VSD.

4200 rpm at 70 Hz or VSD.

Available in 40 bar design:

SAB 193 S

SAB 233 S

SAB 283 S

SAB 355 S

Sound pressure levels in free field, over reflecting plane and one metre distance from the unit.

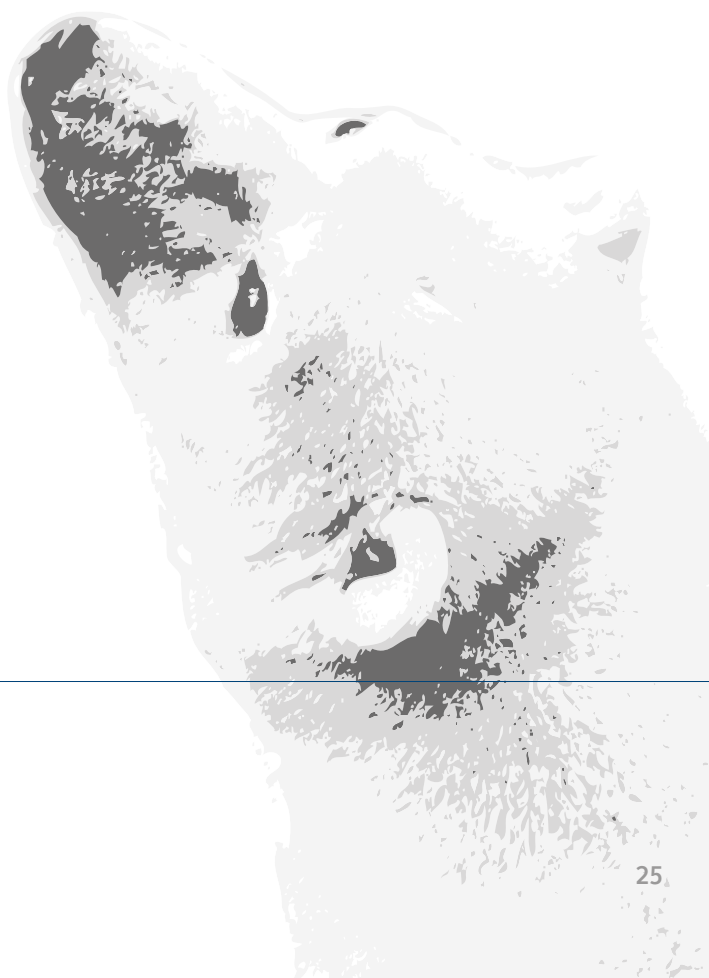

SABROE SAB™ 157 HR high-pressure screw compressor units

Variable-speed high-pressure screw compressor units with swept volumes of 100–600 m³/hour, for use with CO₂ or ammonia as refrigerant

These unique high-pressure compressor units are ideal for low-temperature two-stage freezer installations, such as carbon dioxide–ammonia (R744–R717) cascade refrigeration systems. The 52 bar configuration makes it possible to undertake freezing and defrosting in one single stage with condensing temperatures up to 15°C.

The game-changer SAB 157 HR design radically shifts the boundaries between low-stage and high-stage refrigeration, by keeping the inter-stage temperature above 0°C so that the thermal energy in the discharge gas can be used to defrost the cooling element (hot gas defrosting).

This in turn makes it possible to make big saving on installation, piping and compressor costs because a single SAB 157 HR unit can replace multiple compressors using traditional refrigerants.

Right from the outset, SAB 157 HR units are designed for variable-speed operation and maximum flexibility, doing away with traditional capacity slide valves. Capacity range: 1000–6000 rpm.



SAB 157 HR high-pressure screw compressor unit

Significant advantages	Customer benefits
Stepless, skip-free capacity control ensures that output always matches requirements	Lowest possible operating costs and rapid return on investment
Consistently high performance at both full and part load	Maximum part-load efficiency and low life cycle costs ??
Unique 52 bar unit designed specifically for CO ₂ applications	Makes it possible to undertake freezing and defrosting in one stage
Space-saving small footprint, with fewer moving parts and very low vibration	Exceptional reliability and low maintenance costs
Supports Condition Based Service (CBS) schedules and the SABROE Block Swap Concept	Optimised service/maintenance intervals, with a minimum of unscheduled downtime

Range

One model is available to provide swept volumes of 600 m³/hour at 6000 rpm.

Options

- Thermosyphon and water-cooled oil coolers, with 3-way oil temperature control valve
- Dual external oil filters



SAB 157 HR high-pressure screw compressor block



For R744

Model	Swept volume at 6000 rpm m ³ /h	Capacities in kW at 6000 rpm			Dimensions in mm L x W x H	Weight excluding motor/oil kg	Sound pressure level dB(A)
		Cooling -35/+5°C	-45/-5°C	-50/-5°C			
SAB 157 HR	596	939	630	585	3300 x 1500 x 2100	2600	On request

For R717

Model	Swept volume at 6000 rpm m ³ /h	Capacities in kW at 6000 rpm			Dimensions in mm L x W x H	Weight excluding motor/oil kg	Sound pressure level dB(A)
		Heating +40/90°C	+30/90°C	+20/90°C			
SAB 157 HR	596	1800	1430	1125	3300 x 1500 x 2100	2600	On request

Nominal capacities are based on 6000 rpm at 100 Hz.
The sound pressure level depends on the operating conditions.
SAB 157 HR for R717 is only sold on request.

Chillers based on SABROE core technologies

Chillers meet the demand for indirect cooling

Many industrial and commercial processes and installations require indirect rather than direct cooling. This is normally provided by special chiller units, in which a compressor – rather than acting directly – cools a secondary refrigerant that then provides the desired cooling effect.

The use of secondary refrigerants – water, glycol, brine, etc. – is increasing rapidly because of the demand for safer installations and an intense, continuous focus on energy efficiency.

Another driver lies in both national and international legislation that requires phasing out particular refrigerants because of their environmental impacts.

Meeting the demand for chillers

SABROE therefore provides a range of energy-efficient standardised packaged chiller configurations, all based on high-efficiency SABROE reciprocating and screw compressors that are world-renowned for their reliability.

As a result, SABROE chillers are at the forefront of this rapidly developing specialist market.

Compliance

All SABROE chiller units are fully compliant with appropriate major international design codes and the specifications laid down by the most common classification societies. Approval in accordance with other technical requirements, specific national legislation or other classification societies' requirements is available on request.



SABROE chiller programme

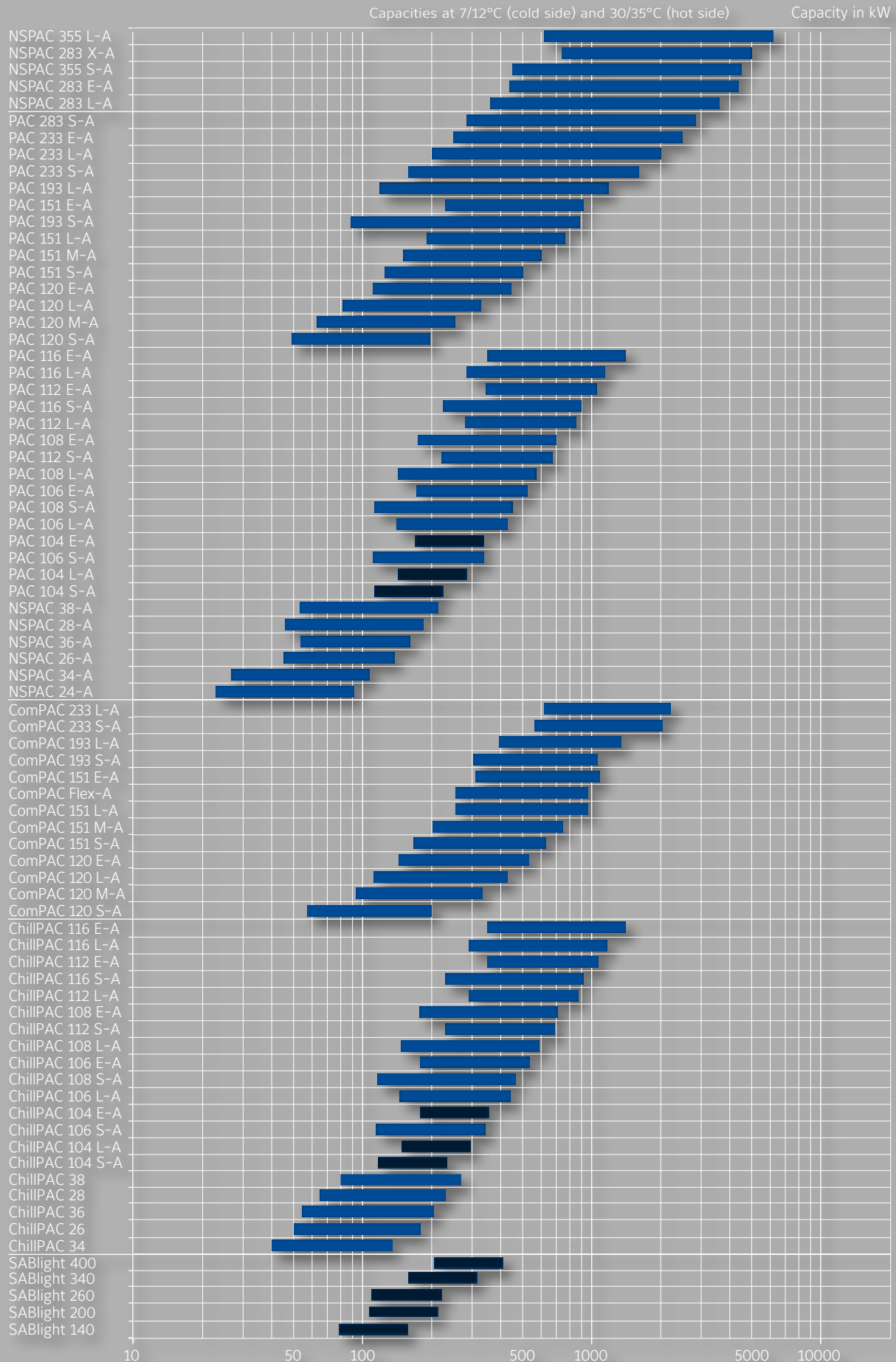

SABROE ChillPAC® chillers

Extremely compact packaged ammonia chillers based on reciprocating compressors, with a 100–1400 kW capacity range

ChillPAC ammonia-based chillers feature an ultra-compact format so narrow that they can even pass through a normal doorway. This is achieved by having an extra-compact shell-and-plate evaporator/condenser, oil separator and control system all built in and fully integrated into a unique vibration-resistant design.

This means ChillPAC units provide exceptional refrigeration capacity – taking full advantage of the many different models of ultra-reliable SABROE reciprocating compressors – while only taking up a minimum of space. This makes ChillPAC units ideal in installations where space is limited, and where there are restrictions on the refrigerant charge used.

ChillPAC chillers are most cost-effective when fitted with a variable-speed drive (VSD) that makes it easy to deal with changing circumstances and different operating requirements.

Range

There are 20 different models in the standard ChillPAC range, with capacities ranging from 90 kW to 1398 kW.



ChillPAC 108

Advantages	Benefits
Factory-assembled, pre-tested packaged units based on SABROE reciprocating compressors world-renowned for their reliability	Easy pre-commissioning makes installation and running-in both faster and cheaper. Factory acceptance tests (FAT) available (as an option)
Exceptionally compact design and fully integrated configuration results in less than half the footprint of bespoke chiller designs	Major savings on both weight and space, resulting in lower installation costs. Much less need for expensive separate machinery rooms
Indirect cooling and uncomplicated flooded evaporating system, using natural ammonia (R717) only	Greater safety and outstanding reliability
Exceptional COP and outstanding part-load performance	Greater cooling effect from a smaller refrigerant charge, and optimum load structure over the entire capacity range
Refrigerant charge 50% smaller than with conventional chillers, because of special condenser/evaporator design	Higher output per unit kW/kg refrigerant, lower unit cost and lower installation costs.

Options

- Variable-speed drive (VSD)
- Soft-starter or Y/D starter
- Desuperheater
- Sub-cooler
- External condenser
- Control panel mounted separately
- S and L models: 1800 rpm at 60 Hz or VSD
- Factory acceptance tests (FAT), customer-witnessed
- Heater package for low-temperature heat pump operation
- Shunt solution for high-temperature difference.

Water chillers (Water: inlet 12°C, outlet 7°C)

Type	Cooling capacity	E-motor	R717 charge	Dry weight	Dimensions in mm			Sound level
	kW	kW	kg	kg	L	W	H	dB(A)
ChillPAC 34	139 *	27	13	2000	2900	1000	2000	70
ChillPAC 26	177 *	33	14	2050	2900	1000	2000	71
ChillPAC 36	205 *	40	14	2100	2900	1000	2000	70
ChillPAC 28	234 *	45	15	2150	2900	1000	2000	73
ChillPAC 38	276 *	55	16	2350	2900	1000	2000	74
ChillPAC 104 S-A	233	45	14	2301	2900	1000	2000	78
ChillPAC 104 L-A	294	55	15	2410	2900	1000	2000	79
ChillPAC 106 S-A	346	75	17	2727	2900	1000	2000	79
ChillPAC 104 E-A	357	75	17	2652	2900	1000	2000	79
ChillPAC 106 L-A	440	90	21	2950	2900	1000	2000	80
ChillPAC 108 S-A	464	90	22	3060	2900	1000	2000	80
ChillPAC 106 E-A	536	110	24	3225	3100	1000	2000	81
ChillPAC 108 L-A	588	110	26	3526	3100	1000	2000	82
ChillPAC 112 S-A	690	132	29	4315	4000	1000	2200	82
ChillPAC 108 E-A	715	132	30	3880	3300	1000	2000	82
ChillPAC 112 L-A	878	160	36	4738	4500	1000	2200	83
ChillPAC 116 S-A	921	200	37	5044	4500	1000	2200	83
ChillPAC 112 E-A	1066	200	41	5196	4600	1000	2200	83
ChillPAC 116 L-A	1167	250	45	5556	4700	1000	2200	83
ChillPAC 116 E-A	1398	315	49	5878	5000	1000	2200	84

Brine chillers (Ethylene glycol 30%: inlet -4°C, outlet -8°C)

Type	Cooling capacity	E-motor	R717 charge	Dry weight	Dimensions in mm			Sound level
	kW	kW	kg	kg	L	W	H	dB(A)
ChillPAC 26	90 *	30	13	2000	2900	1000	2000	70
ChillPAC 36	105 *	33	13	2050	2900	1000	2000	72
ChillPAC 28	119 *	37	14	2100	2900	1000	2000	73
ChillPAC 38	139 *	45	15	2250	2900	1000	2000	73
ChillPAC 104 S-C	116	37	13	2253	2700	1000	2000	78
ChillPAC 104 L-C	150	55	15	2378	2900	1000	2000	79
ChillPAC 106 S-C	172	55	15	2505	2900	1000	2000	79
ChillPAC 104 E-C	185	75	17	2586	2900	1000	2000	79
ChillPAC 106 L-C	222	75	18	2701	2900	1000	2000	80
ChillPAC 108 S-C	227	75	18	2766	2900	1000	2000	80
ChillPAC 106 E-C	272	90	20	2866	2900	1000	2000	80
ChillPAC 108 L-C	295	110	22	3091	3100	1000	2000	82
ChillPAC 112 S-C	339	110	24	3696	3800	1000	2200	82
ChillPAC 108 E-C	363	132	25	3523	3300	1000	2000	82
ChillPAC 112 L-C	440	160	29	4290	4200	1000	2200	83
ChillPAC 116 S-C	450	160	29	4390	4200	1000	2200	83
ChillPAC 112 E-C	544	200	35	4733	4300	1000	2200	83
ChillPAC 116 L-C	586	200	37	4898	4300	1000	2200	83
ChillPAC 116 E-C	718	250	43	5322	4300	1000	2200	83

Condenser: water inlet 30°C, outlet 35°C.

The above data are only valid for the stated temperatures and operating conditions.

Capacities are nominal at 1500 rpm.

* Capacities are nominal at 1800 rpm.

Sound pressure levels in free field, over reflecting plane and one metre distance from the unit.

A = Air conditioning application (temperature above 0°C)

C = Chiller application (temperature below 0°C)

All data and nominal capacities kW at 1500 rpm. S and L models, 60 Hz or VSD operation possible.

Compliance

All SABROE chiller units are fully compliant with appropriate major international design codes and the specifications laid down by the most common classification societies. Approval in accordance with other technical requirements, specific national legislation or other classification societies' requirements is available on request.

All information is subject to change without notice.

SABROE ComPAC™ chillers

Packaged ammonia chillers based on screw compressors, with a 500–2200 kW capacity range

SABROE ComPAC ammonia chillers based on plate-and-shell heat exchangers and the comprehensive SABROE screw compressor programme (SAB 120-151 to SAB 193-233 and SABflex) are distinctive for their compactness. Frequency converter and panel solutions are supplied as standard.

ComPAC chillers with capacities below 1400 kW use the ultra-compact and extremely low-charge SABROE-patented plate-and-shell heat exchangers. Chillers with capacities above 1400 kW use condensers and evaporators of premium quality, integrated into a unique vibration-resistant design.

Range

There are 13 different standard models in this range of ComPAC chillers – both high- and low-temperature versions.

A comprehensive range of equipment options are available to ensure the best possible performance and application versatility.

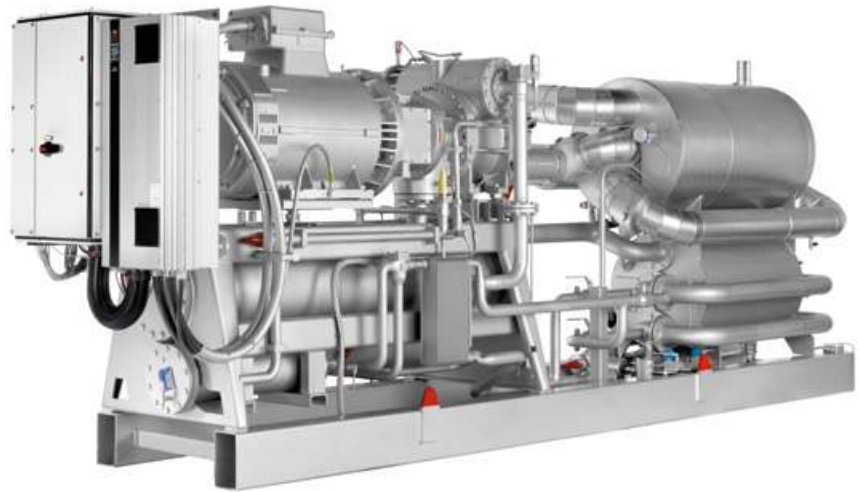

ComPAC chiller

Advantages	Benefits
Factory-assembled, pre-tested packaged units based on renowned SABROE screw compressors	Easy pre-commissioning makes installation and running-in both faster and cheaper. Factory acceptance tests (FAT) available (as an option)
Compact design with a very small footprint compared with bespoke chiller designs	Lower unit cost and lower installation costs
Indirect cooling and uncomplicated flooded evaporating system, using natural ammonia (R717) only	Major savings on both weight and space. Much less need for expensive separate machinery rooms
Exceptional COP and outstanding part-load performance	Greater safety and outstanding reliability
Small refrigerant charge, smaller than conventional chiller charges due to the special condenser/evaporator design	Greater cooling effect from a smaller refrigerant charge, and optimum load structure over the entire capacity range

Options

- Variable-speed drive (VSD)
- Soft-starter or Y/D starter
- Sound enclosure for outdoors mounting
- External condenser
- Control panel mounted separately
- Economiser option for low-temperature brine
- Factory acceptance tests (FAT), customer-witnessed
- Heater package for low-temperature operation
- Shunt solution for high-temperature difference.

Water chillers (Water: inlet 12°C, outlet 7°C)

Type	Cooling capacity	E-motor	R717 charge	Dry weight	Dimensions in mm			Sound level
	kW	kW	kg	kg	L	W	H	dB(A)
ComPAC 120 S-A	200	55	20	3600	5500	1200	2200	85
ComPAC 120 M-A	330	75	25	3800	5500	1200	2200	86
ComPAC 120 L-A	420	90	30	4000	5500	1200	2200	87
ComPAC 120 E-A	540	132	35	4200	5500	1200	2200	89
ComPAC Flex-A	575	160	40	5700	5500	1200	2200	89
ComPAC 151 S-A	630	142	40	5500	5500	1200	2200	91
ComPAC 151 M-A	750	172	45	5800	5500	1200	2200	92
ComPAC 151 L-A	945	223	55	5900	5500	1200	2200	92
ComPAC 151 E-A	1140	250	65	6300	5500	1200	2200	93
ComPAC 193 S-A	1100	250	65	7100	6500	1500	2200	85
ComPAC 193 L-A	1420	315	75	7400	6500	1500	2200	85
ComPAC 233 S-A	2000	400	330	12000	7000	1500	2500	86
ComPAC 233 L-A	2200	500	350	13000	7000	1500	2500	86

Brine chillers (Ethylene glycol 30%: inlet -4°C, outlet -8°C)

Type	Cooling capacity	E-motor	R717 charge	Dry weight	Dimensions in mm			Sound level
	kW	kW	kg	kg	L	W	H	dB(A)
ComPAC 120 S-C	115	45	20	3653	5500	1200	2200	85
ComPAC 120 M-C	185	75	25	3818	5500	1200	2200	86
ComPAC 120 L-C	235	90	30	3997	5500	1200	2200	87
ComPAC 120 E-C	310	117	35	4428	5500	1200	2200	89
ComPAC Flex-C	340	132	45	5667	5500	1200	2200	89
ComPAC 151 S-C	360	132	40	5304	5500	1200	2200	91
ComPAC 151 M-C	430	160	45	5584	5500	1200	2200	92
ComPAC 151 L-C	540	200	55	5833	5500	1200	2200	92
ComPAC 151 E-C	605	250	45	5824	5500	1200	2200	93
ComPAC 193 S-C	610	200	60	6836	6500	1500	2200	85
ComPAC 193 L-C	770	275	60	7165	6500	1500	2200	85
ComPAC 233 S-C	1110	368	230	11100	7000	1500	2500	86
ComPAC 233 L-C	1400	470	270	11900	7000	1500	2500	86

Condenser: water inlet 30°C, outlet 35°C. The above data are only valid for the stated temperatures and operating conditions.

Capacities are nominal at 3600 rpm. SABflex at 6000 rpm. ComPAC 120 S at 1470 rpm.

Sound pressure levels in free field, over reflecting plane and one metre distance from the unit.

A = Air conditioning application (temperature above 0°C)

C = Chiller application (temperature below 0°C)

Compliance

All SABROE chiller units are fully compliant with appropriate major international design codes and the specifications laid down by the most common classification societies.

Approval in accordance with other technical requirements, specific national legislation or other classification societies' requirements is available on request.

SABROE PAC™ chillers

Packaged ammonia chillers based on reciprocating compressors, with a 50–1400 kW capacity range

PAC ammonia-based chillers are fully integrated packaged units, designed to take full advantage of the many different models of ultra-reliable SABROE reciprocating compressors. They are popular because there is such a wide range of different standard sizes, and they are also particularly easy to customise to meet specific requirements.

The integrated design, with the plate evaporator/condenser, oil separator and control system all built in, means PAC units provide exceptional refrigeration capacity while only taking up a minimum of space. They are ideal for use in indirect cooling set-ups, and in installations where it is important to use future-compatible natural refrigerants, such as ammonia.

The advanced technology and the well-matched integration of the component systems make these chillers so energy efficient that their low operating costs make them the most economical choice over the lifetime of a refrigeration plant.

Range

There are 21 different standard models in this range of packaged chillers, with capacities ranging from 45 kW to 1419 kW.

Customised configurations are also available for use with remote air-cooled or evaporative condensers, and for twin or multi-packages, designed to provide particularly large cooling capacities.



PAC 116 chiller

Advantages	Benefits
Factory-assembled, pre-tested packaged units	Easy pre-commissioning makes installation and running-in both faster and cheaper. Factory acceptance tests (FAT) available as an option
Comprehensive selection of compressor capacities, making it easier to match particular requirements	Avoid paying for greater capacity than needed
Very easy access for service	Improves safety, ensures maximum reliability and global sourcing of parts
Indirect cooling and uncomplicated flooded evaporating system, using natural ammonia (R717) only	Greater safety and outstanding reliability
Plate evaporator/condenser are easy to open and service	Routine checks/service can be carried out by operator's own staff

Options

- Variable-speed drive (VSD)
- Soft-starter or Y/D starter
- Desuperheater
- Sub-cooler
- External condenser
- Control panel mounted separately
- NSPAC and PAC-S and -L models: 1800 rpm at 60 Hz or VSD
- Factory acceptance tests (FAT), customer-witnessed.

Water: inlet 12°C, outlet 7°C

Type	Capacity kW	E-motor kW	R717 charge kg	Dry weight kg	Dimensions in mm			Sound level dB(A)
					L	W	H	
NSPAC 24-A	92	22	20	1400	2500	1500	2200	67
NSPAC 34-A	108	22	21	1450	2500	1500	2200	68
NSPAC 26-A	138	30	22	1450	2500	1500	2200	68
NSPAC 36-A	161	37	28	1600	2700	1500	2200	69
NSPAC 28-A	184	37	32	1600	2700	1500	2200	69
NSPAC 38-A	215	45	34	1650	2900	1500	2200	70
PAC 104 S-A	225	45	48	3100	3300	1850	2300	77
PAC 104 L-A	286	55	49	3250	3300	1850	2300	77
PAC 106 S-A	337	75	51	3500	3300	1850	2300	78
PAC 104 E-A	349	75	51	3400	3300	1850	2300	78
PAC 106 L-A	429	90	54	3550	3300	1850	2300	79
PAC 108 S-A	452	90	54	3700	3300	1850	2300	79
PAC 106 E-A	527	110	57	3700	3550	1850	2300	79
PAC 108 L-A	576	110	58	3900	3550	1850	2300	80
PAC 112 S-A	679	132	73	4650	4130	1850	2450	80
PAC 108 E-A	702	160	74	4300	3850	1850	2450	80
PAC 112 L-A	863	200	78	5000	4130	1850	2450	81
PAC 116 S-A	905	200	79	5350	4130	1850	2450	81
PAC 112 E-A	1054	250	84	5300	4550	1850	2450	81
PAC 116 L-A	1151	250	88	5650	4900	1850	2450	82
PAC 116 E-A	1419	280	137	6300	5750	2000	2600	82

Ethylene glycol 30%: inlet -4°C, outlet -8°C

Type	Capacity kW	E-motor kW	R717 charge kg	Dry weight kg	Dimensions in mm			Sound level dB(A)
					L	W	H	
NSPAC 24-C	45	22	19	1400	2500	1500	2200	68
NSPAC 34-C	53	22	20	1400	2500	1500	2200	68
NSPAC 26-C	67	30	21	1450	2500	1500	2200	68
NSPAC 36-C	79	30	22	1500	2600	1500	2200	69
NSPAC 28-C	89	37	30	1550	2600	1500	2200	69
NSPAC 38-C	104	37	32	1600	2700	1500	2200	70
PAC 104 S-C	106	37	47	3000	3300	1850	2300	76
PAC 104 L-C	139	55	48	3050	3300	1850	2300	77
PAC 106 S-C	159	55	49	3250	3300	1850	2300	78
PAC 104 E-C	174	75	50	3200	3300	1850	2300	77
PAC 106 L-C	208	75	51	3450	3300	1850	2300	79
PAC 108 S-C	212	75	52	3550	3300	1850	2300	79
PAC 106 E-C	266	90	56	3600	3300	1850	2300	79
PAC 108 L-C	280	110	55	3650	3300	1850	2300	80
PAC 112 S-C	321	110	68	4400	4130	1850	2450	80
PAC 108 E-C	355	132	74	4100	3600	1850	2450	80
PAC 112 L-C	419	160	74	4600	4130	1850	2450	81
PAC 116 S-C	428	160	74	5150	4130	1850	2450	81
PAC 112 E-C	532	200	83	5050	4130	1850	2450	81
PAC 116 L-C	559	200	80	5400	4130	1850	2450	82
PAC 116 E-C	717	250	132	6000	4550	2000	2600	83

Condenser: water inlet 30°C, outlet 35°C. The above data are only valid for the stated temperatures and operating conditions.

A = Air conditioning application (temperature above 0°C)

C = Chiller application (temperature below 0°C)

All data and nominal capacities kW at 1500 rpm

NSPAC and PAC -S and -L models, 60 Hz or VSD operation possible.

Sound pressure levels in free field, over reflecting plane and one metre distance from the unit.

Compliance

All SABROE chiller units are fully compliant with appropriate major international design codes and the specifications laid down by the most common classification societies.

Approval in accordance with other technical requirements, specific national legislation or other classification societies' requirements is available on request.

All information is subject to change without notice.

SABROE PAC™ chillers

Packaged ammonia chillers based on screw compressors, with a 100–6200 kW capacity range

PAC ammonia-based chillers are fully integrated packaged units, designed to take full advantage of the many different models of ultra-reliable SABROE screw compressors. They are popular because there is such a wide range of different standard sizes, and they are also particularly easy to customise to meet specific requirements.

The integrated design, with the plate evaporator/condenser, oil separator and control system all built in, means PAC units provide exceptional refrigeration capacity while only taking up a minimum of space. They are ideal for use in indirect cooling set-ups, and in installations where it is important to use future-compatible natural refrigerants, such as ammonia.

The advanced technology and the well-matched integration of the component systems make these chillers so energy efficient that their low operating costs make them the most economical choice over the lifetime of a refrigeration plant.

Range

There are 19 different standard models in this range of packaged chillers, with capacities ranging from approx. 109 kW to 6180 kW.

Customised configurations are also available for use with remote air-cooled or evaporative condensers, and for twin or multi-packages, designed to provide particularly large cooling capacities.

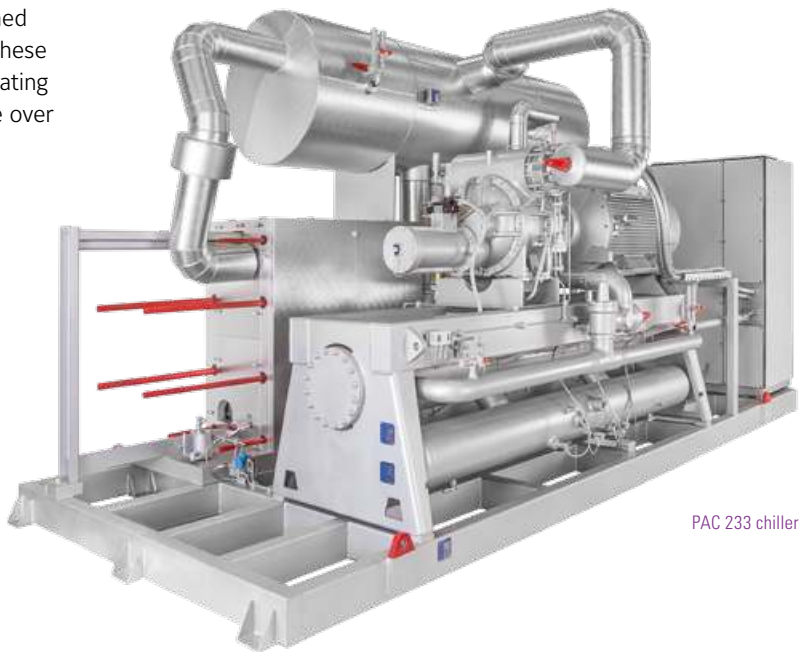

PAC 233 chiller

Advantages	Benefits
Factory-assembled, pre-tested packaged units	Easy pre-commissioning makes installation and running-in both faster and cheaper. Factory acceptance tests (FAT) available as an option
Comprehensive selection of compressor capacities, making it easier to match particular requirements	Avoid paying for greater capacity than needed
Very easy access for service	Improves safety, ensures maximum reliability and global sourcing of parts
Indirect cooling and uncomplicated flooded evaporating system, using natural ammonia (R717) only	Greater safety and outstanding reliability
Plate evaporator/condenser are easy to open and service	Routine checks/service can be carried out by operator's own staff

Options

- Variable-speed drive (VSD)
- Soft-starter or Y/D starter
- Desuperheater
- Sub-cooler
- External condenser
- Control panel mounted separately
- 3600 rpm at 60 Hz or VSD
- 4200 rpm at 70 Hz or VSD (PAC 193, 233, 283, 355)
- Factory acceptance tests (FAT), customer-witnessed.

Water: inlet 12°C, outlet 7°C

Type	Capacity kW	E-motor kW	R717 charge kg	Operational weight kg	Dimensions in mm			Sound level dB(A)
					L	W	H	
PAC 120 S-A	197	55	38	4000	4310	1870	2260	82
PAC 120 M-A	254	75	40	4150	4310	1870	2260	83
PAC 120 L-A	326	75	50	4550	4310	1870	2260	84
PAC 120 E-A	441	110	54	4800	4560	1870	2360	86
PAC 151 S-A	496	132	55	5600	3800	2070	2360	88
PAC 151 M-A	600	132	59	5700	5700	2070	2360	89
PAC 151 L-A	761	200	75	6200	3940	2090	2450	89
PAC 193 S-A	885	200	81	6400	4600	2350	2450	82
PAC 151 E-A	921	200	80	6350	4600	2090	2450	90
PAC 193 L-A	1180	250	91	7000	5300	2350	2450	82
PAC 233 S-A	1595	355	169	11500	5500	2900	3200	83
PAC 233 L-A	2009	400	184	12500	6700	3000	3200	83
PAC 233 E-A	2481	500	211	15200	6700	3050	3400	84
PAC 283 S-A	2859	630	230	17000	7500	3400	3400	85
NSPAC 283 L-A	3596	800	350	20500	7300	3700	4500	83
NSPAC 283 E-A	4367	900	391	25500	8500	3700	4700	83
NSPAC 355 S-A	4516	1000	410	28000	8500	4000	4700	83
NSPAC 283 X-A	4939	1000	450	30000	9100	4000	4700	83
NSPAC 355 L-A	6180	1250	700	40000	10000	4000	6000	83

Ethylene glycol 30%: inlet -4°C, outlet -8°C

Type	Capacity kW	E-motor kW	R717 charge kg	Operational weight kg	Dimensions in mm			Sound level dB(A)
					L	W	H	
PAC 120 S-C	109	55	38	4000	4310	1870	2260	82
PAC 120 M-C	141	75	39	4150	4310	1870	2260	83
PAC 120 L-C	180	75	49	4500	4310	1870	2360	84
PAC 120 E-C	243	110	53	4700	4310	1870	2360	86
PAC 151 S-C	275	110	54	5550	3940	2070	2360	88
PAC 151 M-C	333	132	57	5600	3940	2070	2360	89
PAC 151 L-C	422	160	73	6100	3940	2090	2450	89
PAC 193 S-C	489	200	78	6250	4600	2350	2450	82
PAC 151 E-C	512	200	77	6200	4290	2090	2450	90
PAC 193 L-C	653	250	87	6750	5000	2350	2450	82
PAC 233 S-C	880	315	161	11250	5200	2750	3200	84
PAC 233 L-C	1103	400	175	12100	5800	2750	3200	84
PAC 233 E-C	1373	500	198	14700	6500	2800	3400	84
PAC 283 S-C	1597	560	211	16350	6700	3150	3400	86
PAC 283 L-C	1995	710	230	19000	7100	3700	3400	88
NSPAC 283 E-C	2412	900	374	24500	7300	3700	4500	84
NSPAC 355 S-C	2525	900	380	26000	8000	4000	4700	84
NSPAC 283 X-C	2752	1000	400	28000	8500	4000	4700	84
NSPAC 355 L-C	3418	1200	600	38000	9500	4000	6000	84

Condenser: water inlet 30°C, outlet 35°C. The above data are only valid for the stated temperatures and operating conditions.

A = Air conditioning application (temperature above 0°C)

C = Chiller application (temperature below 0°C)

All data and nominal capacities kW at 3000 rpm.

60Hz or VSD operation possible.

Sound pressure levels in free field, over reflecting plane and one metre distance from the unit.

Compliance

All SABROE chiller units are fully compliant with appropriate major international design codes and the specifications laid down by the most common classification societies.

Approval in accordance with other technical requirements, specific national legislation or other classification societies' requirements is available on request.

All information is subject to change without notice.

SABROE SABlight® air-cooled chillers

Compact air-cooled chillers for outdoor installation, based on a screw compressor, with a 174–430 kW capacity range

The SABlight air-cooled chiller is a particularly compact design that uses V-coil condensers to substantially reduce the overall footprint. The screw compressor and fully brazed plate heat exchanger are mounted underneath the V-coils, resulting in a height of 2.9 m and a width of only 1.3 m.

SABlight units provide a cost-effective alternative to traditional air conditioning, chilled rooms and industrial/process refrigeration. They are designed for quiet running and outdoor operation, and a special ultra-low-noise version is available.

SABlight uses a small propane refrigerant charge, providing an attractive, economical and environmentally responsible alternative to air-cooled chillers that use HFCs as refrigerant.

Range

There are 5 standard models in this range of air-cooled chillers, with capacities ranging from 174 kW to 427 kW.



SABlight air-cooled chiller

Advantages	Benefits
Compact design with small footprint	Easy to mount outdoors – no special machinery room required
Quiet while running Available in both low and ultra-low noise versions	Can be placed close to occupied buildings
Variable-speed drive fitted to both compressor and fans, providing very high coefficient of performance (COP), even under part-load conditions	Low power consumption, which means low operating costs
Designed for maximum safety, with very small natural refrigerant charge (propane R290)	No expenditure on special safety precautions
Easy to mount, install and connect up	Low installation costs and rapid commissioning
Straightforward, uncomplicated construction	Low maintenance costs

Standard equipment

- Control and monitoring system
- Variable-speed drive
- Hot-dip galvanised base frame
- Screw compressor
- Precharged with refrigerant.

Options

- External communication via network and industrial-standard bus systems
- Evaporator heating elements for frost-proofing
- Epoxy coating of condenser surface
- Oil cooler
- Models operating with inlet temperatures below 0°C available on request
- Desuperheater
- Oil pump.

Compliance

All SABlight air-cooled chillers are fully compliant with PED (CE marked and PED approved). Approval in accordance with other classification societies is available on request.



SABlight air-cooled chiller

Technical data										
Type	Cooling capacity kW	Power consumption kW	COP ESEER	R290 charge kg	Dry weight kg	Dimensions in mm			Nominal load current A	Sound level dB(A)
						L	W	H		
SABlight A140-1	178	54	4.7	24	2300	5260	1250	2835	110	55
SABlight A140-2	174	51	4.6	24	2300	5260	1250	2835	115	45
SABlight A200-1	235	70	4.8	24	2500	5260	1250	2835	155	55
SABlight A200-2	232	69	4.6	32	3000	6660	1250	2835	160	45
SABlight A260-1	293	85	4.6	32	3000	6660	1250	2835	190	55
SABlight A260-2	288	85	4.6	40	3300	8060	1250	2835	190	45
SABlight A340-1	356	101	4.7	40	3700	8060	1250	2835	215	55
SABlight A340-2	341	102	4.6	48	4200	9460	1250	2915	220	45
SABlight A400-1	427	115	4.8	48	4400	9460	1250	2915	250	55
SABlight A400-2	413	122	4.6	56	4800	10860	1250	2915	250	45

Capacities are nominal and based on water temperature 12/7°C, ambient temperature 30°C.

Sound pressure levels in free field. All sound measuring has been carried out according to ISO 9614-2 at a distance of 10 m.

ESEER = European Seasonal Energy Efficiency Ratio (Eurovent Institute, Europe).

Fans and VSD are included in the power consumption.

All information is subject to change without notice.

SABROE CAFP™ CO₂/ammonia freezers

Compact packaged freezer systems using reciprocating compressors, and CO₂/ammonia as refrigerant, with a 100–800 kW capacity range

The highly customised SABROE CAFP freezer systems are based on a cascade system that combines the advantages of CO₂ on the low-temperature side and ammonia on the high-temperature side.

These packaged systems are built around SABROE reciprocating compressors that use CO₂ as refrigerant, which gives them a significantly greater cooling capacity than corresponding compressors using ammonia. This in turn makes the low-temperature compressor much smaller, and the whole package significantly more compact than traditional two-stage ammonia-based freezer systems.

As a result, each standard CAFP package can be fitted inside a standard 20-foot shipping container, if required. This does away with the need for a special machinery space, and the freezer installation can easily be moved if required.

Compared with conventional ammonia-based two-stage or single-stage systems with economisers, a CAFP unit uses significantly less power in the temperature range down to -55°C.

This results in energy savings of as much as 15% compared with traditional two-stage ammonia systems, and up to 45% compared with single-stage set-ups.



CAFP unit controlled and monitored by Unisab III systems controller

Advantages	Benefits
Compact design that fits inside a standard 20-foot container	Big savings on installation costs
High COP and extremely low power consumption, even at part load	Low operating costs
Use of CO ₂ as low-temperature refrigerant reduces piping complexity and costs	Reduces installation costs
Very small ammonia charge, located on the unit itself	No risk of ammonia leaks in production areas, cold stores and working areas
CO ₂ is a simple, inexpensive natural refrigerant	Low operating costs

Range

There are 6 standard models in this range of freezer systems, with capacities ranging from 87 kW to 793 kW.

All CAFP units are operationally tested with refrigerant before dispatch. Factory acceptance tests (FAT) available.

Standard equipment

- Double control panel including Unisab III systems controller
- CO₂ pump separator including two pumps (one standby)
- Shell-and-tube cascade cooler with double-tube sheet to minimise any risk of CO₂ and ammonia mixing
- Standstill cooling unit, with separate control panel and power supply, to limit CO₂ pressure
- Automatic oil recovery system in both circuits
- Water-cooled condenser (plate heat exchanger type) on ammonia side
- Insulation of all cold parts.

Options

- Variable-speed drive
- Titanium plates in condenser
- Oversized CO₂ pump separator for high CO₂ evaporator volume
- Oversized CO₂ pumps for higher circulation rate
- Oversized ammonia condenser for higher cooling water temperature
- Fully welded shell-and-tube cascade cooler
- External interstage load, including a brine cooler on the R717 side of the cascade cooler.
- Special version for use with remote condenser
- Configurations for use with HCFC refrigerants instead of ammonia on high-pressure side.

Compliance

All SABROE chiller units are fully compliant with appropriate major international design codes and the specifications laid down by the most common classification societies.

Approval in accordance with other technical requirements, specific national legislation or other classification societies' requirements is available on request.

Model	Evaporation temperature °C	Capacity kW	Power consumption kW	Compressors R744/R717	Minimum NH ₃ charge kg (approx.)	Minimum CO ₂ charge l (approx.)	Dimensions in mm (approx.) L x W x H	Weight (approx.) kg	Sound pressure level dB(A)
CAFP 80	-50	87	64	HPO 24 / SMC 104 S					78
CAFP 80	-45	112	74	HPO 24 / SMC 104 L					80
CAFP 80	-40	144	84	HPO 24 / SMC 104 E	120	300	5500 x 2400 x 3000	7000	79
CAFP 80	-35	144	82	HPO 24 / SMC 106 S					79
CAFP 120	-50	131	94	HPO 26 / SMC 106 S					80
CAFP 120	-45	169	110	HPO 26 / SMC 106 L					80
CAFP 120	-40	217	126	HPO 26 / SMC 106 E	120	350	5700 x 3200 x 3300	10000	80
CAFP 120	-35	264	137	HPO 26 / SMC 108 L					82
CAFP 160	-50	174	125	HPO 28 / SMC 108 S					80
CAFP 160	-45	223	147	HPO 28 / SMC 108 L					82
CAFP 160	-40	288	167	HPO 28 / SMC 108 E	120	350	5900 x 2900 x 3300	11000	82
CAFP 160	-35	363	188	HPO 28 / SMC 112 L					83
CAFP 200	-50	211	150	HPC 104 / SMC 106 E					80
CAFP 200	-45	277	177	HPC 104 / SMC 108 E					82
CAFP 200	-40	353	200	HPC 104 / SMC 112 L	180	350	5900 x 3100 x 3800	14000	82
CAFP 200	-35	415	214	HPC 104 / SMC 112 L					83
CAFP 300	-50	324	228	HPC 106 / SMC 112 L					82
CAFP 300	-45	416	263	HPC 106 / SMC 112 E					82
CAFP 300	-40	511	290	HPC 106 / SMC 116 L	300	800	6300 x 3200 x 3900	16000	83
CAFP 300	-35	599	310	HPC 106 / SMC 116 L					83
CAFP 400	-50	421	296	HPC 108 / SMC 112 E					82
CAFP 400	-45	520	332	HPC 108 / SMC 116 L					83
CAFP 400	-40	667	375	HPC 108 / SMC 116 E	400	800	6500 x 3700 x 4000	19000	83
CAFP 400	-35	793	398	HPC 108 / SMC 116 E					83

Condenser: water inlet 25°C, outlet 30°C.
Capacities are nominal, 1500 rpm at 50 Hz.
Power consumption applies to compressors only.
Refrigerant charge depends on application.

Dry weight (approx.).
Sound pressure levels in free field, over reflecting plane and one metre distance from the unit.

All information is subject to change without notice.

Heat pumps based on SABROE core technologies

Heat pump pioneer

SABROE is one of the world's leading suppliers of heat pump systems for commercial and industrial use. We were one of the pioneers of the whole idea of the energy benefits to be reaped from using heat pumps in industry – long before they became greentech-fashionable.

SABROE HeatPAC heat pumps are the ideal solution for effectively exploiting low-temperature waste heat, and turning it into hot water (up to 90°C), using only a minimum of electrical energy.

Ammonia as refrigerant

SABROE industrial heat pumps use natural ammonia (R717) as refrigerant. Each unit is customised for the specific use and the particular installation, making sure that a minimum of thermal energy is used to provide maximum effect.



Customised two-stage heat pump

SABROE heat pump programme

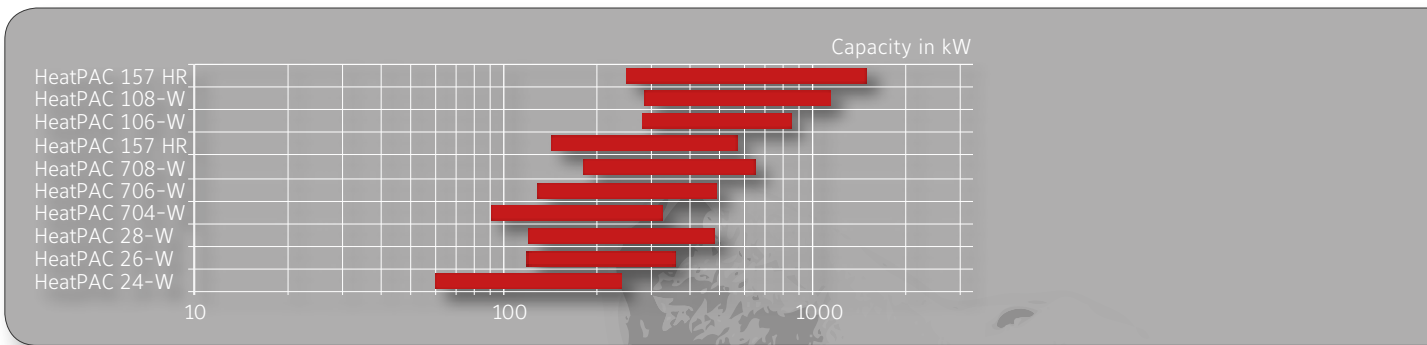

Heat pumps

SABROE HeatPAC™ heat pumps

Ammonia-based heat pumps using a reciprocating compressor, with a 240–1200 kW capacity range

HeatPAC units are extremely compact heat pumps based on ultra-reliable SABROE HPO/ HPC high-pressure reciprocating compressors, using ammonia as refrigerant. They are usually most cost-effective when fitted with a variable-speed drive (VSD) that makes it easy to deal with changing circumstances and different operating requirements. These highly customisable integrated units are based on a unique vibration-resistant design, featuring an uncomplicated flooded evaporating system. They provide exceptional heat pump capacity from the smallest possible footprint, and with only a very small refrigerant charge.

SABROE HeatPAC heat pumps are the ideal solution for effectively exploiting low-temperature waste heat, and turning it into hot water (up to 70°C), using only a minimum of electrical energy. These units are designed to provide a cost-effective way to tackle needs for cooling and heating at the same time, providing an extremely high coefficient of performance (COP).

Range

There are 6 standard models in this range of heat pump systems, with capacities ranging from 240 kW to 1149 kW.

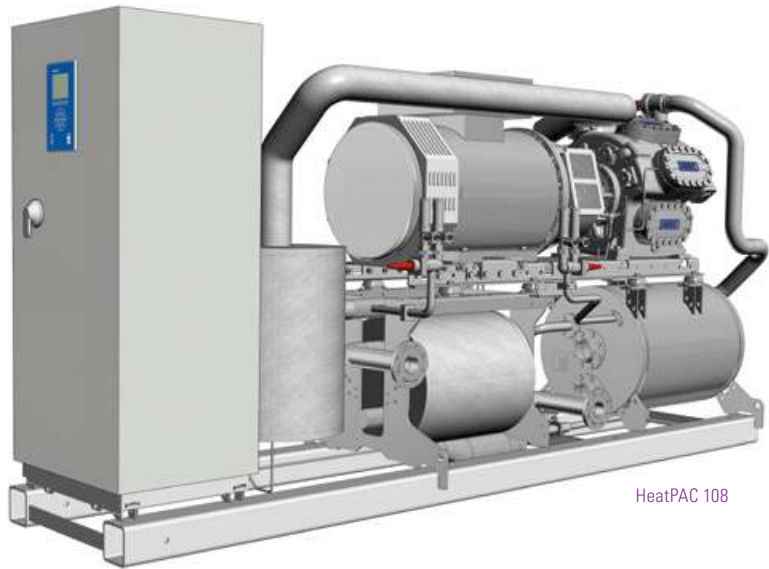

HeatPAC 108

Advantages

Factory-assembled, pre-tested packaged units based on SABROE reciprocating compressors world-renowned for their reliability

Integrated configuration weighs less, and has less than half the footprint of bespoke heat pump designs

Indirect cooling and an uncomplicated flooded evaporating system, using natural ammonia (R717) only

Exceptional COP and outstanding part-load performance

Refrigerant charge 50% smaller than with conventional heat pumps, because of special condenser/evaporator design

Benefits

Easy pre-commissioning makes installation and running-in both faster and cheaper

Low installation costs. Easy to mount even in confined spaces or unconventional locations

Greater safety and outstanding reliability

Low operating costs

Higher output per unit kW/kg refrigerant, lower unit cost and lower installation costs

Options

- Cascade evaporator
- Variable-speed drive (VSD)
- Soft-starter or Y/D starter
- De-superheater
- Subcooler
- Control panel mounted separately
- HeatPAC 24, 26 and 28: 60 Hz or VSD
- Factory acceptance tests (FAT), customer-witnessed.

Compliance

All HeatPAC heat pumps are fully compliant with appropriate major international design codes and the specifications laid down by the most common classification societies.

Approval in accordance with other technical requirements, specific national legislation or other classification societies' requirements is available on request.



Unisab control for heat pump application

Condenser water inlet +64°C, outlet +70°C
Evaporator water inlet +39°C, outlet +34°C

Type	Heating capacity kW	Cooling capacity kW	Power consumption kW	COP heat	R717 charge kg	Dry weight kg	Dimensions in mm			Sound level dB(A)
							L	W	H	
HeatPAC 24-W	240	202	38	6.3	20	2020	2800	1000	2000	75
HeatPAC 26-W	359	302	57	6.3	23	2230	2850	1000	2000	76
HeatPAC 28-W	484	408	77	6.3	25	2420	2900	1000	2000	77
HeatPAC 104-W	570	478	93	6.1	28	2630	3050	1000	2000	81
HeatPAC 106-W	852	715	138	6.2	37	3300	3750	1000	2000	82
HeatPAC 108-W	1149	965	186	6.2	48	3950	4050	1000	2000	83

W = Heat pump unit water/water.

Motor: 3 x 400 volt / 50 Hz, 1470 rpm.

All data and nominal capacities kW at 1500 rpm.

HeatPACs 24, 26, 28: 60 Hz or VSD operation possible.

Sound pressure levels in free field, over reflecting plane and one metre distance from the unit.

SABROE HeatPAC™ HPX heat pumps

Single-stage high-pressure ammonia-based heat pumps, using a reciprocating compressor, with a 100–650 kW capacity range

SABROE HeatPAC™ HPX heat pumps are compact units with an integrated single-stage configuration that features less than half the space and weight requirements of any other heat pump designs usually needed to achieve 90°C hot water outputs.

These energy-efficient units feature a breakthrough HPX hybrid compressor design that allows differential pressures as high as 40 bar and discharge pressures as high as 60 bar, combined with space-saving evaporator technology from the ChillPAC™ packaged ammonia chiller.

HeatPAC HPX heat pumps make it easy to produce hot water at temperatures up to 90°C, using any suitable source of low-temperature heat, with only tiny energy inputs needed.

They provide a low-cost supply of hot water at temperatures ideal for sterilisation and pasteurisation – as well as many other hygiene-sensitive functions and processes.



HeatPAC HPX

Advantages	Benefits
Factory-assembled, pre-commissioned units based on ultra-reliable SABROE reciprocating compressors	Easy, rapid commissioning saves time money and manpower, and minimises disruption
Compact single-stage configuration weighs less and takes up less space than bespoke and/or two-stage heat pump designs	Easy to mount or retrofit, even in confined spaces or unconventional locations
Exceptional Coefficient of Performance (COP) in high-temperature single-stage configuration	High energy-efficiency, low operating costs
Variable-speed drive (VSD) and Unisab III compressor package controller as standard	Outstanding part-load performance and maximum operating flexibility
Service and maintenance based on Load Based Service (LBS) schedules	Improved reliability, longer service intervals, minimal downtime, low cost of ownership

Options

- Cascade evaporator
- Subcooler
- Control panel mounted separately
- Factory acceptance tests (FAT), customer-witnessed.

Compliance

HeatPAC HPX heat pumps are fully compliant with appropriate major international design codes and the specifications laid down by the most common classification societies.

Approval in accordance with other technical requirements, specific national legislation or other classification societies' requirements is available on request.

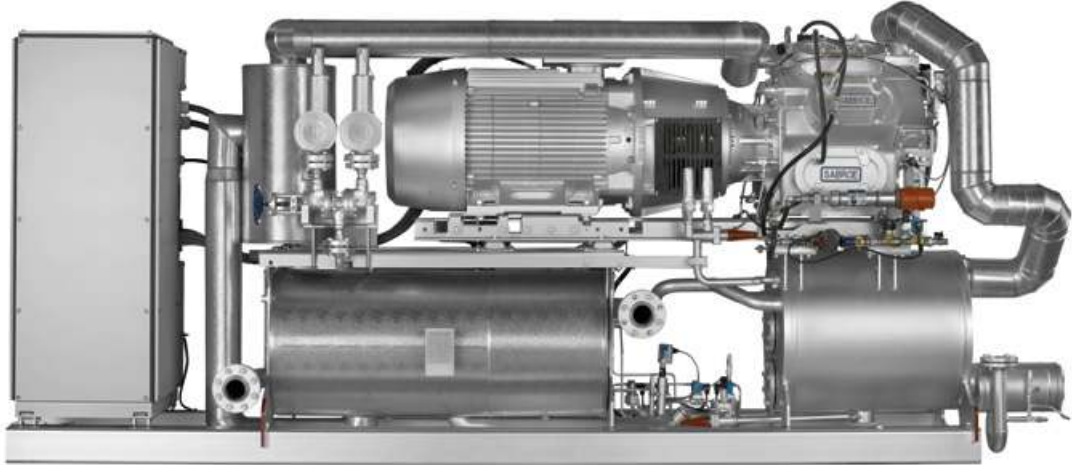

HeatPAC HPX

Condenser water inlet +70°C, outlet +90°C
Evaporator water inlet +39°C, outlet +34°C
Evaporation 30°C, 16K sub-cooling

Type	Heating capacity kW	Cooling capacity kW	Power consumption kW	COP heat	R717 charge kg	Dry weight kg	Dimensions in mm			Sound level dB(A)
							L	W	H	
HeatPAC 704-W	326	249	82	4.0	25	~3500	~3500	1000	2100	~83
HeatPAC 706-W	489	373	123	4.0	30	~4200	~3700	1000	2100	~85
HeatPAC 708-W	652	498	164	4.0	35	~5000	~4100	1000	2100	~86

Approximate values.

W = Heat pump unit water/water
 Capacities are nominal at 1800 rpm
 VSD drive is standard

Sound pressure levels in free field, over reflecting plane and one metre distance from the unit.

SABROE HeatPAC™ heat pumps

Ammonia-based heat pumps using a screw compressor, with a capacity of up to 1800 kW

HeatPAC units are extremely compact heat pumps based on ultra-reliable SABROE high-pressure screw compressors, using ammonia as refrigerant.

These highly customisable integrated units, featuring an uncomplicated flooded evaporating system, provide exceptional heat pump capacity from the smallest possible footprint, and with only a very small refrigerant charge. They are designed to provide a cost-effective way to tackle needs for cooling and heating at the same time, providing an extremely high coefficient of performance (COP).

SABROE HeatPAC heat pumps are the ideal solution for effectively exploiting low-temperature waste heat, and turning it into hot water (up to 90°C), using only a minimum of electrical energy.

SABROE HeatPAC heat pumps provide considerable scope for customisation to meet specific customer requirements.

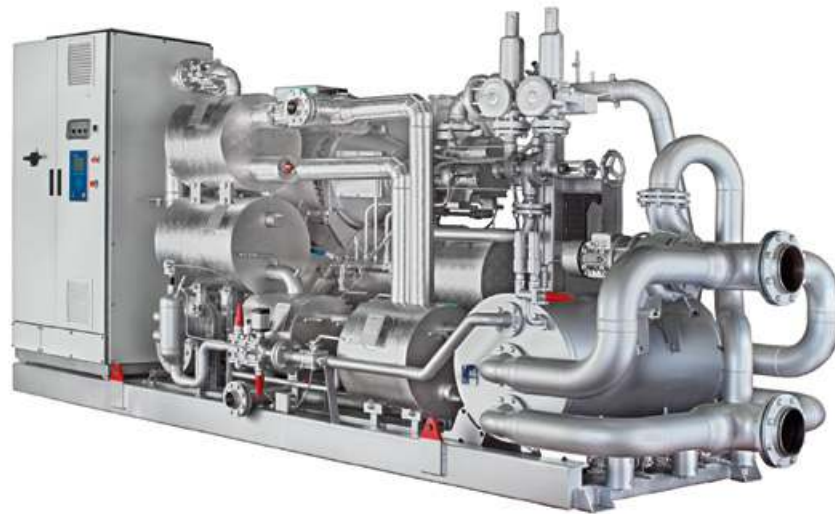

HeatPAC 157 HR

Advantages	Benefits
Factory-assembled, pre-tested packaged units based on SABROE screw compressors world-renowned for their reliability	Easy pre-commissioning makes installation and running-in both faster and cheaper. Factory acceptance tests (FAT) available as an option
Integrated configuration weighs less, and has less than half the footprint of bespoke heat pump designs	Low installation costs. Easy to mount even in confined spaces or unconventional locations
Indirect cooling and an uncomplicated flooded evaporating system, using natural ammonia (R717) only	Greater safety and outstanding reliability
Exceptional COP and outstanding part-load performance	Low operating costs
Refrigerant charge 50% smaller than with conventional heat pumps, because of special condenser/evaporator design	Higher output per unit kW/kg refrigerant, lower unit cost and lower installation costs

Options

- Cascade evaporator
- Control panel mounted separately
- Factory acceptance tests (FAT), customer-witnessed.

Compliance

All HeatPAC heat pumps are fully compliant with appropriate major international design codes and the specifications laid down by the most common classification societies.

Approval in accordance with other technical requirements, specific national legislation or other classification societies' requirements is available on request.

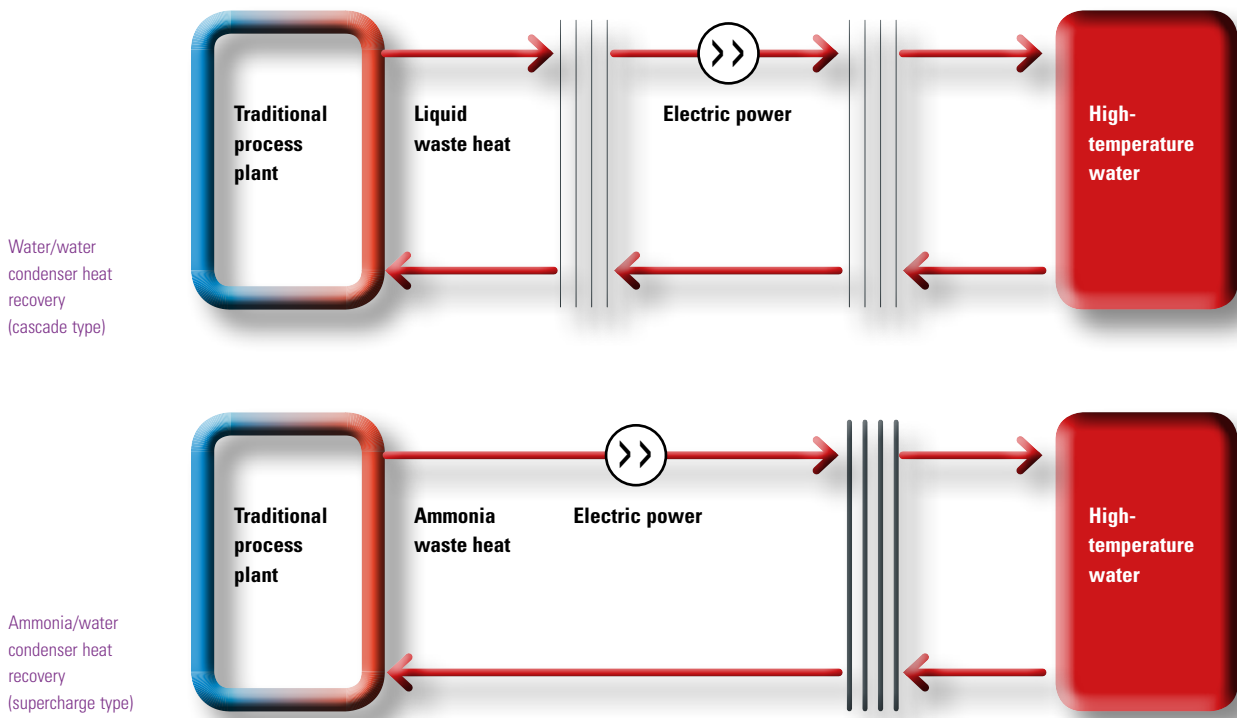

The HeatPAC 157 HR is a versatile heat pump that can cope with a wide range of operating conditions. These units are particularly efficient under part-load conditions due to the variable speed drive (1000–6000 rpm) fitted as standard.

Each unit is specially configured to comply with the specific set of operating conditions, in order to ensure the most effective exploitation of the waste heat available.

HeatPAC 157 HR											
	Cold side				Hot side					Power motor kW	COP
	Temperature in °C	Temperature out °C	Flow m ³ /h	Cooling capacity kW	Temperature in °C	Temperature out °C	Flow m ³ /h	Heating capacity kW			
Water	40	35.9	300	1422	Water	40	85	34.8	1792	407	4.4
Water	30	26.8	300	1107	Water	40	85	28.2	1453	381	3.8
Water	20	17.6	300	818	Water	40	85	22.0	1121	335	3.3
Water	10	8.3	300	588	Water	40	85	16.5	852	290	2.9

Capacities are nominal at 6000 rpm. Specific capacity must be calculated for actual running conditions.

SABROE control systems



Control systems for every requirement

Matching operations to conditions

One of the most effective ways to improve the overall efficiency of your refrigeration setup is to make sure your processes and operations are always in tune with constantly changing operating parameters and equipment status, as well as unpredictable weather and climate conditions.

SABROE control solutions and sensor systems combine to leverage the effectiveness and operational reliability of all kinds of HVACR systems, as well as the efficiency of the industrial processes of which they are a part.

SABROE digital monitoring and data management technologies make it easy to harvest, collate and apply operating data on all levels, right from local equipment conditions to high-level operational status and analysis reports.

These systems enable you to take fully informed decisions when dealing with changes in – and changes to – operating conditions. Reliable, easy-to-use data helps you improve the energy efficiency of your operations, reduce your operating costs and boost your return on investment.

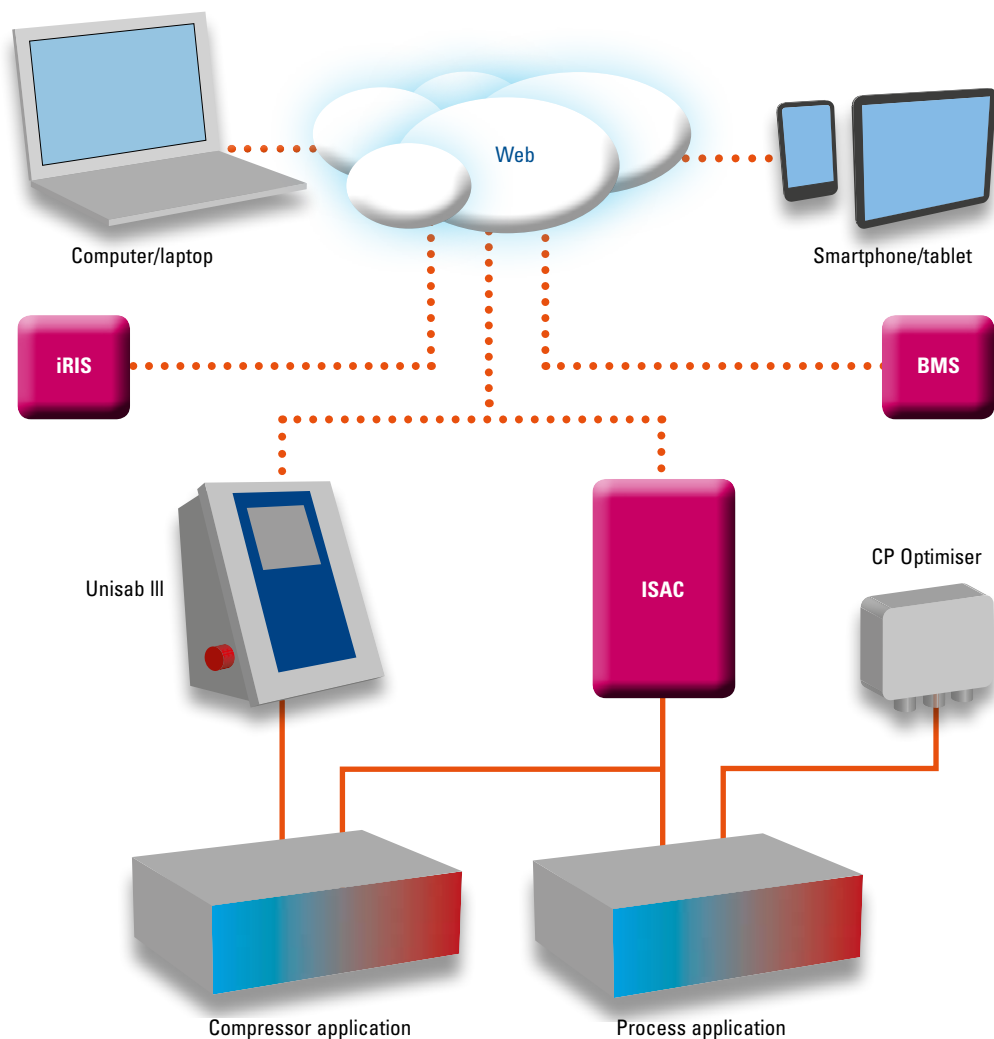

Control systems

SABROE Unisab™ III

Integrated systems controller for refrigeration compressors, chillers and heat pumps

Unisab III systems controllers are connectivity hubs that help make sure refrigeration installations have the best possible performance, maximum uptime and lowest possible operating costs.

These important control units are pre-equipped and pre-configured with the connectivity equipment and protocols necessary for monitoring and controlling a wide range of compressors, compressor packages, chillers and heat pumps – as well as using this data for fault-finding and analysis.

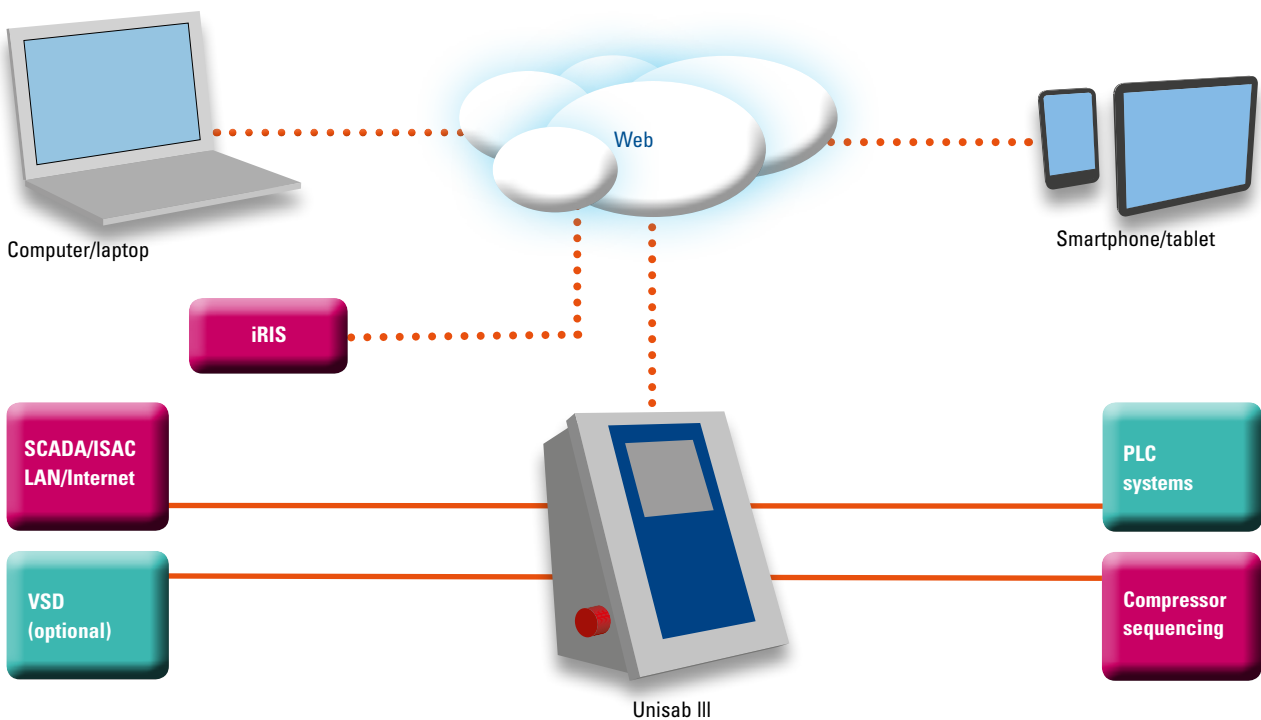

Advantages

Single, fully integrated control system for use with virtually all types of compressors and chillers

Easy to integrate into the vast majority of industrial control systems, providing seamless transfer of data between systems

Monitoring, control and diagnostics capabilities combined in one compact, integrated unit

Compressor sequencing and load sharing are possible without additional equipment

Intuitive, easy-to-use interface, with a consistent “look and feel”

Benefits

Ensures more effective monitoring, control and diagnostics of a wide range of key refrigeration installations

Ensures effective management of important operating data and secures the production process for best performance

Does away with the need for multiple systems, resulting in significant equipment savings

Keeps power consumption to a minimum and reduces operating costs

Requires fewer operator skills, resulting in lower training costs



Unisab Event apps are available for both iOS and Android devices

Connectivity

The Unisab III systems controller has normal industry-standard communication ports fitted as standard, and therefore does not require additional communication gateways.

Data can then be made available via any kind of network, where virtually any computer can be used to monitor and operate the Unisab III systems controller.

Functionality

- Service on demand schedule
- Unisab app for smartphone
- Configurable for both screw compressors and reciprocating compressors, with or without variable-speed drive (VSD), and using any refrigerant
- Built-in regulation of suction pressure, water temperature, discharge pressure, etc.
- Limitations on suction pressure, discharge pressure, motor current, etc.
- Logging of operating history and profiles for effective fault-finding and diagnosis
- Email dispatch in case of alarm or shut down.

Retrofit

A wide range of Unisab III retrofit kits are available to provide all the advantages of upgrading a wide range of existing compressors to a modern controls standard for improved performance and control system integration.



Connectivity	Multiple communication ports, including Modbus TCP, Profibus DP and Sequence Bus, as standard
Smartphone app	Available for both iOS and Android devices
Sequencing.	As many as 14 refrigeration compressors, chillers and heat pumps of different makes and types can be linked in sequence, to ensure effective load sharing and capacity optimisation
Diagnostics.	Detailed operating data documenting 30 shut-down situations
Refrigerants	Pre-loaded with the requisite data about all refrigerants normally used
Operating languages	Multiple languages available as standard, with additional languages as options
Enclosure.	IP54
Ambient temperature	0–55°C
Power supply.	85–250 volt AC, 50–60 Hz
Dimensions (H x W x D)	380 x 300 x 210 mm
Weight	6.5 kg

All information is subject to change without notice.

SABROE VSD panel

Electrical panel solution for refrigeration compressor units with variable-speed drive (VSD)

SABROE VSD (Variable-Speed Drive) panel solutions are the ideal way to integrate the unique SABROE combination of refrigeration compressor unit know-how with electrical and controls experience and technologies. This paves the way to optimising the operation of refrigeration compressor units, and thus bring down here-and-now operating costs as well as longer-perspective life cycle costs for the owner.

SABROE VSD panels are integrated electrical panel solutions with a built-in frequency inverter and additional control equipment that together make them very easy to integrate into your overall power supply and control system.

Adding an optional Unisab III systems controller makes the VSD panel a complete plug-and-play controls and motor drive solution, ready to ensure your compressor package delivers maximum cooling power with minimum life cycle costs.

Factory-mounted units provide the best value for money, because delivering complete pre-vetted units ensures trouble-free operation and an electrical installation in full accordance with relevant standards and best practice. It also ensures end-users big savings on the man-hours required for configuring the overall equipment set-up.



SABROE VSD panel

Benefits of building in SABROE VSD panels

Competitive prices

SABROE VSD panels are competitively priced electrical panel solutions that contain a frequency inverter and everything needed for easy, compliant integration into the overall power supply and control system.

Saves you time

Integrating a SABROE VSD panel into any variable-speed compressor unit will shave off a major part of the man-hours normally allocated to electrical engineering, design, documentation, installation and commissioning of the compressor, chiller or heat pump unit.

Low life cycle cost

Combining a SABROE VSD panel with a Unisab III systems controller brings down the life cycle cost of the compressor unit as a whole. Improved part load characteristics (higher COP), achieved by a combination of the unique Unisab III yield control philosophy and the variable speed, along with the load-based service utility (service on demand) integrated in the Unisab unit, provide the owner with an extremely flexible compressor package with the big additional benefits of low life cycle costs.

The VSD panels are available for the SABROE compressor, chiller and heat pump units specified below. These panels are available as standard for power configurations up to 450 kW. Configurations up to 1000 kW available on request.

Factory-mounted

- ChillPAC chillers
- PAC chillers
- HeatPAC heat pumps.

Separate delivery for site mounting

- ChillPAC chillers
- PAC chillers
- HeatPAC heat pumps
- Screw compressors (all VSD-enabled)
- Reciprocating compressors (all VSD-enabled).

SABROE VSD panels are mounted in a standardised painted-steel cabinet, and include the following equipment

- Electrical engineering, documentation and parameter settings list for the frequency inverter
- Danfoss FC102 frequency inverter, including RFI filter
- Unisab III controller for panel mounting (optional – must be selected separately)
- Main circuit breaker
- Control voltage transformer
- Emergency stop and emergency stop relay
- Motor protection
- Current signal to Unisab III
- Relays for signals to Unisab III
- Hour counter
- Terminals for interlock with pumps, etc.
- MCB for control voltage to panel
- MCB for control voltage to Unisab III
- MCB for power to immersion heater in oil separator
- Cable inlet/outlet in panel bottom.

Technical data
 Power supply: 3x400 V, 50/60 Hz, +/-10%
 Earthing/supply system: TN-S
 Partitioning: Form 1
 Colour: Light grey
 Ingress protection class: IP54
 Compliance: CE

Nominal output [kW / amp]	Dimensions in mm		
	W	H	D
30 kW / 61A	816	1434	624
37 kW / 73A	816	1434	624
45 kW / 90A	816	1434	624
55 kW / 106A	816	1434	624
75 kW / 147A	816	1434	624
90 kW / 177A	816	1434	624
110 kW / 212A	816	1626	624
132 kW / 260A	816	1626	624
160 kW / 315A	816	1818	624
200 kW / 395A	816	1818	624
250 kW / 480A	816	1818	624
315 kW / 600A	816	1818	624
355 kW / 658A	1200	2202	816
400 kW / 745A	1200	2202	816
450 kW / 800A	1200	2202	816

All information is subject to change without notice

SABROE SABflex® VSD panel

Electrical panel solution for refrigeration screw compressors with variable-speed drive (VSD)

SABROE panel solutions for screw compressor units fitted with variable-speed drive are the ideal way to integrate the unique SABROE combination of refrigeration compressor know-how with electrical and controls experience and technologies. This paves the way to optimising the operation of refrigeration compressor units, and thus bring down here-and-now operating costs as well as longer-perspective life cycle cost for the owner.

The SABROE SABflex VSD solution for screw compressors is a compact split solution with a separate panel and VSD. The panel includes a Unisab III systems controller as standard.

The SABflex VSD solution is mainly intended for applications where both the inverter and panel are mounted directly onto the compressor unit, or where the inverter is positioned in a different place than the control panel.

Factory-mounted units provide the best value for money, because delivering complete pre-vetted units ensures trouble-free operation and an electrical installation in full accordance with relevant standards and best practice. It also ensures end-users big savings on the man-hours required for configuring the overall equipment set-up.



SABROE SABflex VSD panel

Benefits of building in SABROE SABflex VSD solutions

Competitive prices

SABROE SABflex VSD solutions are competitively priced and include a frequency inverter and a separate electrical control panel with a Unisab III systems controller and everything needed for easy, compliant integration into the overall plant power supply and control system.

Saves you time

Integrating a SABROE SABflex VSD solution into one of the variable-speed compressor units listed on page 2 will shave off a major part of the man-hours normally allocated to electrical engineering, design, documentation, installation and commissioning of the compressor unit.

Low life cycle cost

The SABflex VSD solution with a Unisab III systems controller brings down the life cycle cost of the compressor unit as a whole.

Improved part load characteristics (higher COP), achieved by a combination of the unique Unisab III yield control philosophy and the variable speed, along with the load-based service utility (service on demand) integrated in the Unisab unit, provide the owner with an extremely flexible compressor unit with the big additional benefits of low life cycle costs.

The SABflex VSD solution is available for the SABROE screw compressor units specified below. These panels are available as standard for power configurations from 75 kW to 315 kW.

Factory-mounted (75–315 kW)

- SABflex
- SAB 120–151 series
- SAB 193 S.

On request (315–1000 kW)

- SAB 193 series, 233 series, 283 series, 355 series.

Separate delivery for site mounting

- SABflex
- SAB 120–151 series
- SAB 193 S.

SABROE SABflex VSD panel solutions comprise a frequency inverter and a control panel in a standardised painted-steel cabinet, containing the following equipment

- Electrical engineering, documentation and parameter settings list for the frequency inverter
- Unisab III controller
- Main circuit breaker
- Control voltage transformer
- Emergency stop and emergency stop relay
- Motor protection
- Current signal to Unisab III for proactive overload counteraction
- Relays for signals to Unisab III
- Hour counter
- MCB for control voltage to panel
- MCB for control voltage to Unisab III
- MCB for power to immersion heater in oil separator
- Cable inlet/outlet in panel bottom.

Technical data - panel

Power supply: 3x400 V, 50/60 Hz, +/-10%
 Earthing/supply system: . . . TN-S
 Partitioning: Form 1
 Colour: Light grey
 Ingress protection class: . . . IP54
 Compliance: CE
 Dimensions in mm: W 600 x H 950 x D 400

Technical data - frequency inverter

Type: Danfoss FC102
 Filter included: RFI/EMI
 Ingress protection class: IP54
 Dimensions in mm W x H x D
 75–90 kW: 370 x 770 x 330
 110–160 kW: 325 x 901 x 378
 200–315 kW: 420 x 1060 x 378

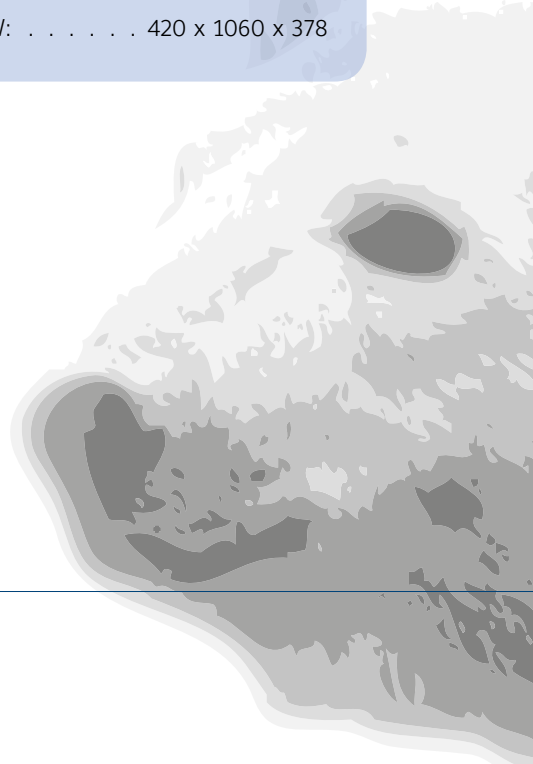

SABROE softstarter FSD panel

Electrical panel solution for refrigeration compressor units with fixed-speed drive (FSD)

SABROE panel solutions for compressor units fitted with fixed-speed motors are the ideal way to integrate the unique SABROE combination of refrigeration compressor know-how with electrical and controls experience and technologies. This paves the way to optimising the operation of fixed-speed refrigeration compressor units, and thus bring down here-and-now operating costs as well as longer-perspective life cycle costs for the owner.

SABROE softstarter FSD panels are integrated electrical panel solutions with a built-in softstarter and additional control equipment that together make them very easy to integrate into your overall power supply and control system.

Adding an optional Unisab III systems controller makes the softstarter FSD panel a complete plug-and-play controls and motor starter solution, ready to supply the motor and ensure that the fixed-speed compressor unit delivers maximum cooling power at a minimum life cycle cost.

SABROE softstarter FSD panels are an advanced electronic alternative to conventional Y/D starters, enabling a smoother start and (in some setups) making it possible to reduce the starting current better than a Y/D starter.



SABROE softstarter FSD panel

Benefits of building in SABROE softstarter FSD panels

Competitive prices

SABROE softstarter FSD panels are competitively priced electrical panel solutions that contain a softstarter FSD and everything needed for easy, compliant integration into the overall power supply and control system.

Saves you time

Integrating a SABROE softstarter FSD panel into any fixed-speed compressor unit will shave off a major part of the man-hours normally allocated to electrical engineering, design, documentation, installation and commissioning of the compressor, chiller or heat pump unit.

Low life cycle cost

Combining a SABROE softstarter FSD panel with a Unisab III systems controller brings down the life cycle cost of the compressor unit as a whole. The unique Unisab III yield control philosophy along with the load-based service utility (service on demand) integrated in the Unisab unit, provides the owner with an extremely flexible and low life cycle cost compressor unit.

Softstarter FSD panels are available for the SABROE compressor, chiller and heat pump units specified below. These panels are available as standard for power configurations up to 560 kW. Configurations above this are available on request.

Factory-mounted

- ChillPAC chillers
- PAC chillers
- HeatPAC heat pumps.

Separate delivery for site mounting, all on request

- ChillPAC chillers
- PAC chillers
- HeatPAC heat pumps
- All screw compressors
- All reciprocating compressors.

Factory-mounted units provide the best value by ensuring trouble-free operation and an electrical installation in full accordance with relevant standards and best practice. It also ensures end-users big savings on the man-hours required for configuring the overall equipment set-up.

SABROE softstarter FSD panels are mounted in a standardised painted-steel cabinet, and include the following equipment:

- Electrical engineering and documentation
- ABB softstarter
- In-line contactor for breaking power supply in case of emergency stop
- Unisab III controller for panel mounting (optional – must be selected separately)
- Main circuit breaker
- Control voltage transformer
- Emergency stop and emergency stop relay
- Motor protection
- Current signal to Unisab III
- Relays for signals to Unisab III
- Hour counter
- Terminals for interlock with pumps, etc.
- MCB for control voltage to panel
- MCB for control voltage to Unisab III
- MCB for power to immersion heater in oil separator
- Power inlet in panel top.

Technical data

Power supply: 3x400 V, 50/60 Hz, +/-10 %

Earthing/supply system: TN-S

Partitioning: Form 1

Colour: Light grey

Ingress protection class: IP54

Compliance: CE

Nominal output kW	Dimensions in mm		
	W	H	D
15	600	600	200
22	600	600	200
30	600	600	200
37	600	800	300
45	600	800	300
55	600	800	300
75	800	1000	300
90	800	1000	300
110	800	1000	300
132	800	1000	300
160	800	1200	300
200	1000	1400	300
250	1000	1400	300
315	1000	1400	300
355	1000	1800	400
400	1000	1800	400
450	1000	1800	400
500	1000	1800	400
560	1000	1800	400

All information is subject to change without notice

SABROE Y/D starter FSD panel

Electrical panel solution for refrigeration compressors with fixed-speed drive (FSD)

SABROE panel solutions for compressor units fitted with fixed-speed motors are the ideal way to integrate the unique SABROE combination of refrigeration compressor know-how with electrical and controls experience and technologies. This paves the way to optimising the operation of fixed-speed refrigeration compressor units and thus bring down here-and-now operating costs as well as longer-perspective life cycle cost for the owner.

SABROE Y/D starter panels are integrated electrical panel solutions with conventional Y/D starters and additional control equipment that together make them very easy to integrate into your overall power supply and control system.

Adding the optional Unisab III systems controller to the panel makes the Y/D starter panel a complete plug-and-play controls and motor starter solution, ready to supply the motor and ensure that the fixed-speed compressor package delivers maximum cooling power at a minimum life cycle cost.



SABROE Y/D starter panel

Benefits of building in SABROE Y/D starter panels

Competitive prices

SABROE Y/D starter FSD panels are competitively priced electrical panel solutions that contain a Y/D starter and everything needed for easy, compliant integration into the overall plant power supply and control system.

Saves you time

Integrating a SABROE Y/D starter FSD panel into a fixed-speed compressor unit will shave off a major part of the man-hours normally allocated to electrical engineering, design, documentation, installation and commissioning of the compressor, chiller or heat pump unit.

Low life cycle cost

Combining a SABROE Y/D starter FSD panel with a Unisab III systems controller brings down the life cycle cost of the compressor unit as a whole. The unique Unisab III yield control philosophy along with the load-based service utility (service on demand) integrated in the Unisab unit, provide the owner with an extremely flexible compressor package with the big additional benefits of low life cycle costs.

Y/D starter FSD panels are available for the SABROE compressor, chiller and heat pump units specified below. These panels are available as standard for power configurations up to 560 kW. Configurations above this are available on request.

Factory-mounted

- ChillPAC chillers
- PAC chillers
- HeatPAC heat pumps.

Separate delivery for site mounting, all on request

- ChillPAC chillers
- PAC chillers
- HeatPAC heat pumps
- All screw compressors
- All reciprocating compressors.

Factory-mounted units provide the best value for money, because delivering complete units ensures trouble-free operation and an electrical installation in full accordance with relevant standards and best practice. It also ensures end-users big savings on the man-hours required for configuring the overall equipment set-up.

SABROE Y/D starter FSD panels are mounted in a standardised painted-steel cabinet, and include the following equipment

- Electrical engineering and documentation
- Y/D starter
- Unisab III controller for panel mounting (optional – must be selected separately)
- Main circuit breaker
- Control voltage transformer
- Thermal overload motor protection
- Current signal to Unisab III for proactive overload counteraction
- Relays for signals to Unisab III
- Hour counter
- Terminals for interlock with pumps, etc.
- MCB for control voltage to panel
- MCB for control voltage to Unisab III
- MCB for power to immersion heater in oil separator
- Power inlet in panel top.

Technical data

Power supply: 3x400 V, 50/60 Hz, +/-10%

Earthing/supply system: TN-S

Partitioning: Form 1

Colour: Light grey

Ingress protection class: IP54

Compliance: EN60 204-1

Nominal output kW	Dimensions in mm		
	W	H	D
15	600	600	200
22	600	600	200
30	600	600	200
37	600	800	300
45	600	800	300
55	600	800	300
75	800	1000	300
90	800	1000	300
110	800	1000	300
132	800	1000	300
160	800	1200	300
200	1000	1400	300
250	1000	1400	300
315	1000	1400	300
355	1000	1800	400
400	1000	1800	400
450	1000	1800	400
500	1000	1800	400
560	1000	1800	400

All information is subject to change without notice

SABROE chiller plant controller

Integrated solution for managing and monitoring the controls equipment in chiller plants

The SABROE chiller plant controller is a compact, easy-to-install control panel that contains a pre-programmed PLC system and touch panel for monitoring and controlling a wide range of external equipment that is not part of the chiller itself, but that serves the chilled water distribution system as well as other key equipment in the chiller plant.



Advantages and benefits of the SABROE chiller plant controller

Combines advanced technology and operating data to leverage the operational benefits of modern chillers

Consolidates industrial refrigeration and chilled water plant control know-how and experience into one single control box

Paves the way to streamlined operation of a wide range of chiller plant functions

Compact, fully integrated solution that's easy to link up to the vast majority of chiller plant set-ups

Saves on engineering time, and makes plant and chiller integration and commissioning easier

Can be used for remote monitoring and remote operation

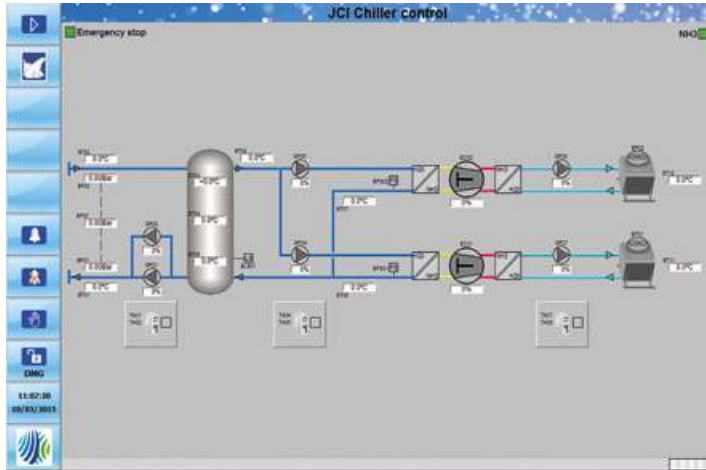

The SABROE chiller plant controller provides users with straightforward on-screen configuration of equipment throughout the chiller plant.

You simply select the number and type of chillers, the type and number of condensers, the condenser control method and the distribution system design, including buffer tank option.

You also simply click on the number and functions of sensors, valves, pumps and fans.

The chiller plant controller (basic) provides

- Differential pressure monitoring and control of pumps on the consumer side of the buffer tanks
- Buffer tank temperature control function, with remote start/stop of chillers
- Load distribution between chillers, if multiple chillers are fitted
- Low-temperature protection of condenser circuit
- Optimum condensing pressure control of condenser side, to match changing outdoor conditions
- Monitoring of temperatures and pressures, and of the functioning of switches, motors and valves
- Choice of direct or VSD drive control for each motor. VSD control can be by conventional digital/analogue signals or by Profinet data communication with the VSDs (must be Danfoss or ABB)
- Remote monitoring and plant operation capability, via internet.

Connectivity options

Both versions are available with a 3G modem and VPN router for wireless internet connection.

The type and make of drive for pumps and for condenser fans are configurable in both versions. You can choose between conventional starter methods and VSD drive. The VSD drive option means you can use Danfoss and ABB VSD drives featuring Profinet connectivity and extended monitoring.

The chiller plant controller (extended) provides

The same as the basic version, with the addition of:

- Ability to monitor and operate the Unisab control units on chiller packages, right from the touch panel
- Advanced free-cooling control
- Inputs for flow and electrical power transmitter for COP and cooling capacity calculations.

Control panel specifications

Cabinet	600 x 800 x 300 mm (HxWxD) painted steel plate, IP44
Connectivity	Touch panel: Ethernet interface for remote monitoring and operation PLC: Ethernet/Profinet interface for software service and connectivity to VSDs
Main components	Main switch, 24V DC power supply, relays and terminals, Siemens S7-1500SP PLC and 12-inch Siemens Comfort touch panel

All information is subject to change without notice

SABROE CP Optimiser™

Automatic device for balancing R717 condensing pressure against compressor efficiency

Many refrigeration systems that use R717 (ammonia) as refrigerant and feature an evaporative condenser are operated using a fixed set point to maintain a constant condensing pressure. This is rarely ideal, as the energy consumption of the compressors typically increases by 3% for every °C the condensing pressure rises – shaft power consumption is directly influenced by condensing pressure. This impacts overall operating costs and plant efficiency.

Reducing condensing pressure improves compressor efficiency, but itself also requires energy. Maximum overall efficiency stems from the best possible balance between compressor energy consumption and the energy required to reduce condensing pressure.

The CP Optimiser automatically calculates this energy balance, taking into account changing loads and conditions. This paves the way to considerable savings on energy bills, which means the CP Optimiser normally pays for itself within a matter of months.

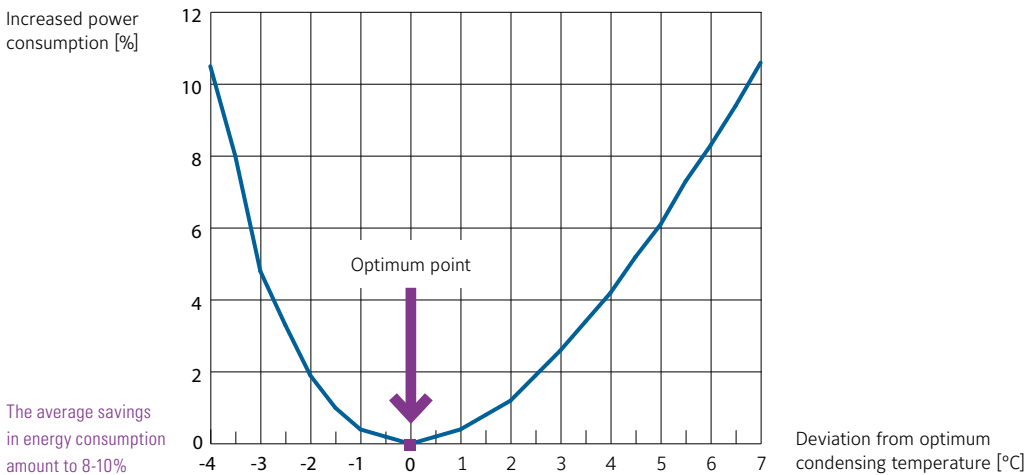

Advantages

Automatic operation based on inputs from just two sensors – temperature and humidity

Output signal can be connected directly to PLCs and frequency converters

No time-consuming programming or complicated technical set-up required

No manual intervention or special operator skills required

No special requirements for integration into new or existing R717-based refrigeration set-ups

Benefits

Substantial reduction in compressor energy consumption, resulting in lower operating costs

Easy to integrate with modern monitoring and control systems to ensure maximum efficiency

Easy to commission and operate, and helps eliminate human error

Virtually no maintenance, calibration or attention necessary after commissioning

Straightforward, inexpensive way to boost operating efficiency and reduce running costs

Where it's used

The CP Optimiser is highly recommended for inclusion in all new installations.

Installing the CP Optimiser in existing installations provides immediate savings on electricity costs.

The CP Optimiser works with the following equipment:

- Evaporative condensers
- Air-cooled condensers
- Dry cooler
- Open cooling towers.

Mounting

The CP Optimiser unit is a small box of electronics that is easy to mount in virtually any convenient location, either indoors or outdoors.

The unit only requires a 24-volt DC power supply and data from appropriate sensors for measuring temperature and relative humidity.

Integration of the CP Optimiser

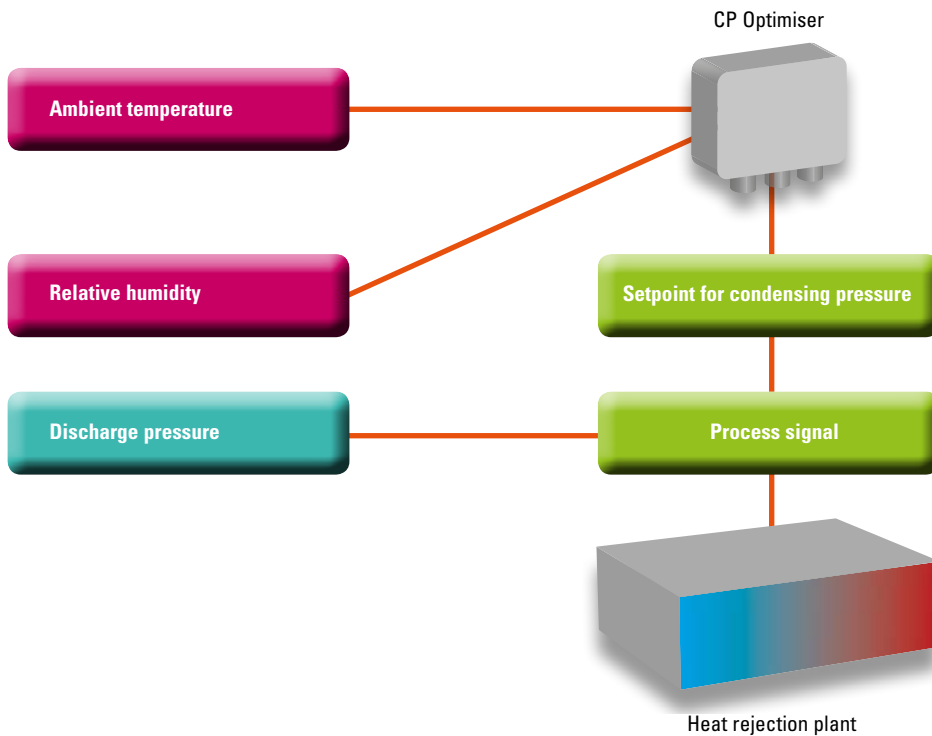

Supply voltage	. . .	24-volt DC
Inputs	Temperature 4–20 mA/0–50°C
Relative humidity	. . .	4–20 mA/0–100% RH
Outputs	Setpoint signals configurable to 4–20 mA or 0–10 volt DC
Dimensions (H x W x D)	115 x 90 x 55 mm
Enclosure	IP54
Cable connections	. . .	4 x PG7

Temperature and relative humidity sensors are not included with the SABROE CP Optimiser, but are available as optional equipment.
Controller (PLC) not included.

SABROE Integrated Standard Automation Concept (ISAC™)

Monitoring and control interface configuration system for industrial refrigeration installations

ISAC is a unique SABROE software with a toolbox for designing and configuring refrigeration control and monitoring set-ups of virtually all kinds. It provides an effective way to integrate SCADA graphics with PLC functionality in order to ensure effective, reliable monitoring and control of both large and small industrial refrigeration installations.

ISAC modules provide standardised, pre-vetted solutions for almost any installation, based on consistent, industry-standard data inputs and outputs that ensure seamless, glitch-free exchanges of data between many different kinds of equipment, regardless of capacity, configuration or manufacturer.



Advantages

Extensive SABROE practical experience is embedded in all ISAC modules

All modules are designed as modular building blocks and based on standardised interfaces and data exchange configurations

Each module designed and tested individually to eliminate technical incompatibilities

Supports a wide range of standard configurations, ranging from single touch screens to multiple workstations

Based on standardised components with a very high degree of documentation, for maximum consistency and efficiency

Benefits

Ensures rapid, cost-effective application of best practise

Minimises time required for design, planning, configuration and service

Greater safety, greater reliability and lower operating costs

Easy to scale to the exact functionality required

High saving potential on commissioning, running in and system optimisation, as well as on energy consumption

Where and how ISAC can be used

The SABROE ISAC system is easily scalable to meet a broad spectrum of refrigeration plant configurations. It provides advanced, flexible control functions with intuitive user features designed for the best match with the performance and technical requirements of each installation.

The ISAC system toolbox is designed to enable controls application engineers with only basic PLC and SCADA programming skills to build advanced, structured and error-free program applications. Once engineers are familiar with the toolbox and how to use it, ISAC makes it possible to build applications much faster than with conventional programming methods.

Extensive field and factory testing of the ISAC toolbox ensures error-free modules and paves the way to smooth, effective commissioning without the usual subsequent adjustments and fault corrections.

Access to the ISAC toolbox requires membership of the ISAC user community, and the ISAC community administrators provide new members with free training courses.

ISAC is easily applicable to both new and existing refrigeration setups, including extension schemes and retrofits of complete refrigeration plants.

Standard features

- Defrost queue, automatic temperature-controlled defrost time, multiple room temperature control setups, etc.
- Automatic equalisation of running hours in installations with multiple pumps and fans
- Differential pressure control of NH₃ pumps
- Manual control possibility of all motors, valves and other actuators
- Hour counters for all motors
- Historical trending
- Alarm and shutdown monitoring
- And more.

ISAC is based on – and completely compatible with – industry-standard Siemens S7 hardware and GE IFIX Proficy SCADA software.

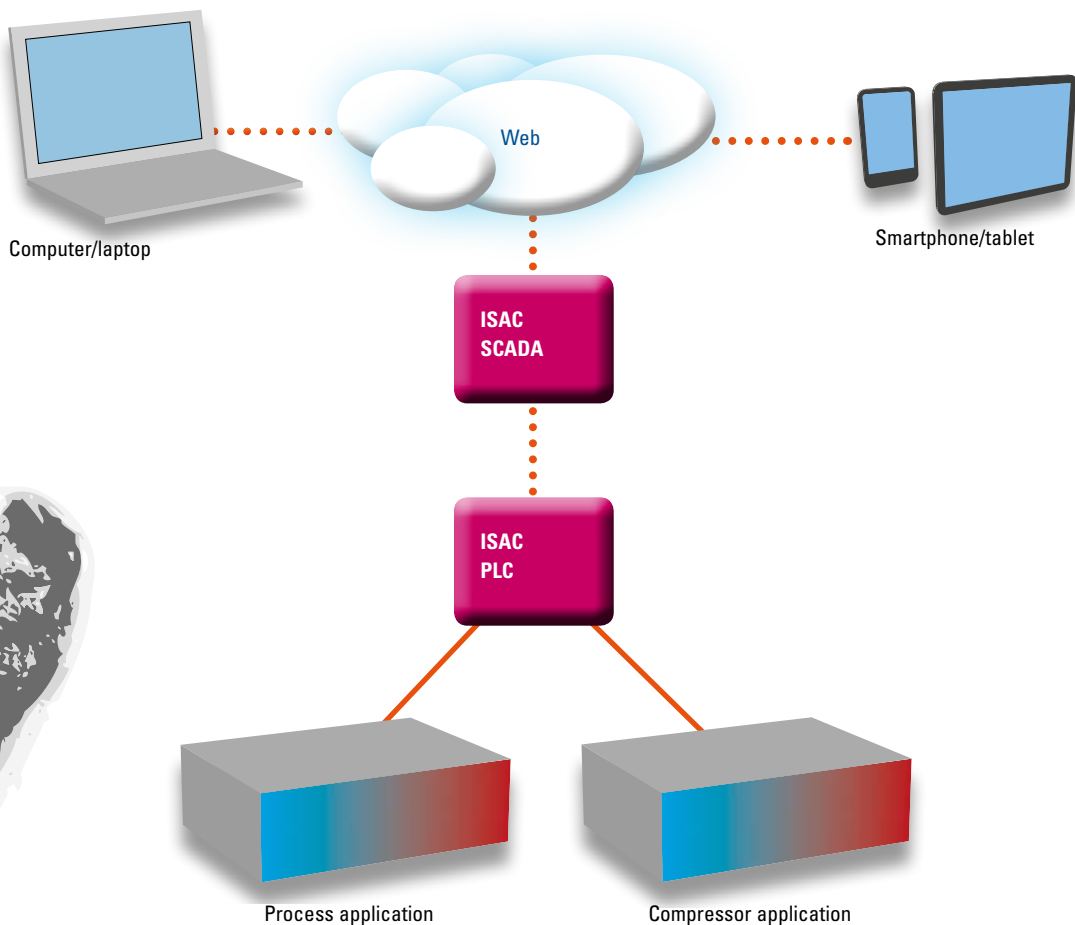

All information is subject to change without notice.

SABROE AP1000™ air purger

Improves performance and reduces operating costs for all types of industrial ammonia refrigeration equipment

The AP1000 Air Purger is specially designed to maintain the efficiency of an ammonia-based refrigeration setup by removing any air present in the refrigerant charge. Air is an un-condensable gas that reduces the effective surface of the condenser and evaporators, resulting in poorer refrigeration performance and higher operating costs.

Any air entering the refrigeration equipment also contains moisture. The mix of water, oxygen and ammonia tends to break down the compressor oil, resulting in loss of viscosity and lubricating properties and premature wear of compressor parts.

Removing air restores any gradual loss of refrigeration capacity, thus making it possible to either increase any production related to refrigeration output, or to reduce energy consumption. Typical performance improvements average 5–10% of the overall refrigeration capacity, or a corresponding 5–10% reduction in power consumption.

The AP1000 features an easy-to-connect control box connected to both the air purger and up to 16 purge points, via settings entered with the 4-inch touch screen on the front of the electrical panel. The box is prepared for connecting additional purge box modules, if more than 16 purge points are required.



Advantages	Benefits
Protects against gradual reductions in cooling capacity	Greater cooling capacity
Constantly purges efficiency-sapping air from refrigeration equipment	Reduced energy consumption for refrigeration equipment (normally 5–10%)
Uncomplicated design	Rapid return on investment (normally less than 12 months for medium-sized plants)
No maintenance required	Less oil decomposition and fewer unexplained refrigeration equipment stoppages
Easy to install	More stable operation Lower refrigeration service and maintenance costs

Installing the AP1000 air purger

Installation of the air purger, as illustrated below, is fairly simple. A solenoid valve must be fitted in each purge point line and connected to the control box.

How to operate

The control box monitors the level indicator in the vessel as well as controlling the 3 solenoid valves on the air purger itself and up to 16 solenoid valves mounted in purge lines.

Settings for the on and off periods of the purge point solenoid valves are entered on the touch panel.

Remote monitoring and control of the air purger:

- Green lamp indicates purge active
- Red lamp indicates fuse fault
- Remote activation of the air purger (potential-free "HP compressor running" signal to digital input)
- Remote monitoring of fuse fault (potential-free contact)

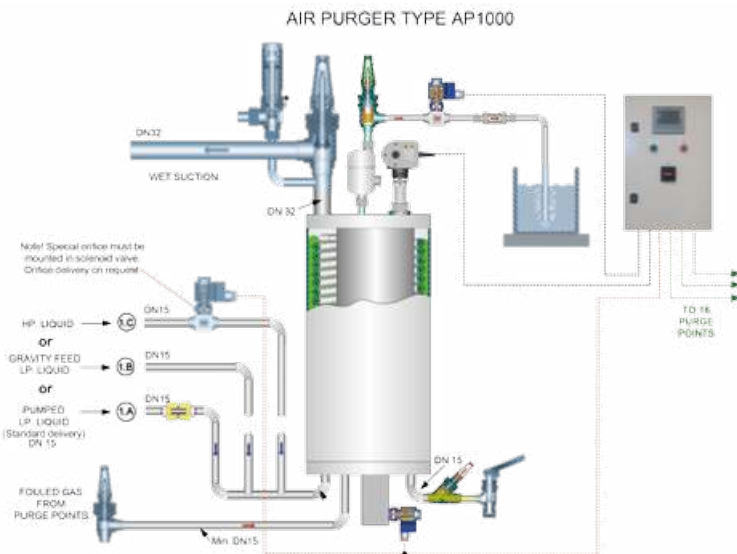

Technical data for the AP1000 air purger

Material Carbon steel/stainless steel 1.4541
 Dimensions H x W x D 1300 x 550 x 370 cm
 Condensing capacity 10 to 13 kW
 Refrigerant Suited for nearly all refrigerants
 Ingress protection IP65
 Compliance CE/PED 97/23/EC

Technical data for the control box

Power supply 230VAC 50HZ
 Dimensions H x W x D 600 x 400 x 300 mm
 Encapsulation/
 Ingress protection Painted-steel plate/IP54
 Contents Main switch
 Siemens S7-1200 PLC
 Siemens KTP400 Basic 4-inch
 Lamps indicating operation
 and fault
 Relays on outputs
 Output voltage for solenoids 230 VAC 50 Hz
 Compliance CE

SABROE Intelligent Remote Information Services (iRIS™)

Reporting and documentation system supporting fully-informed decisions on plant optimisation

Intelligent Remote Information Services (iRIS) is a unique SABROE software platform (managed by Johnson Controls) that registers, captures and collates performance data from all types of industrial refrigeration and thermal transfer equipment.

The iRIS system processes data such as:

- Load distribution and power consumption
- Performance patterns and fluctuations over time
- Statistics for shutdowns and alarms to reveal any irregularities in operation
- Comparisons and benchmarking between the different plants in a company, and operations in different countries.

The iRIS system is part of a complete service concept, working on the basis of information collected and structured by the iRIS server to form different reports and services. These are available by subscription, tailored to the requirements of each individual installation.



Advantages	Benefits
Reliable, comprehensive operating data documenting what is actually happening in the refrigeration installation	Best possible basis for streamlining and optimising operations based on documented facts
Performance and energy consumption benchmarks on a comparative basis	Greater capacity, reduced energy consumption and better plant performance
More cost-effective operations and solid facts for maintenance and extension	Solid operating data as the basis for decisions about new investment and new equipment configurations
Identifying potential problems and inefficiencies before they give rise to disruption	Predictive maintenance and lower service costs
Analysis and guidance by refrigeration technology experts	Access to world-class technical assistance and optimisation knowledge

Compatibility/integration

The iRIS software platform can be adapted to a wide range of refrigeration systems, right from individual compressors to complete refrigeration plants, and is equally well suited for new installations and existing plants.

iRIS is designed to interface seamlessly with Unisab III compressor controllers and plant control systems designed using ISAC toolbox modules. It is also possible to integrate with other systems where data are made available.

Advantages of comparative analysis

The ground-breaking iRIS platform enables owners and operators of refrigeration systems to benefit from solid comparative data, built up over an extended period. This valuable data is automatically stored, structured and presented so that it can be interpreted and applied by Johnson Controls refrigeration technology experts, to tweak and streamline the plant's operating profile.

Customers benefit from direct access to all the expertise and experience available from one of the world's biggest companies in this field – and on the basis of documented performance data.

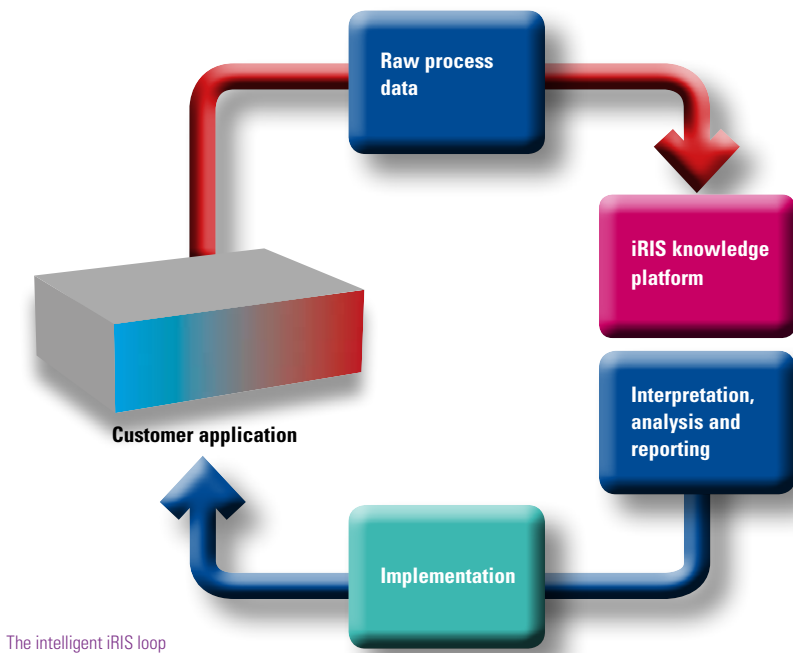

The intelligent iRIS loop

SABROE End-of-Line Test Centre

Full satisfaction – no surprises

Not only are SABROE systems at the forefront of industrial refrigeration technology, they're also backed by state-of-the-art facilities for pre-delivery, pre-commissioning testing.

We rigorously test the performance of every unit before it leaves the factory, so you can be 100% sure it lives up to your expectations in full when it arrives. You're entitled to expect full transparency – and we make sure SABROE systems deliver.

All SABROE units are tested before dispatch

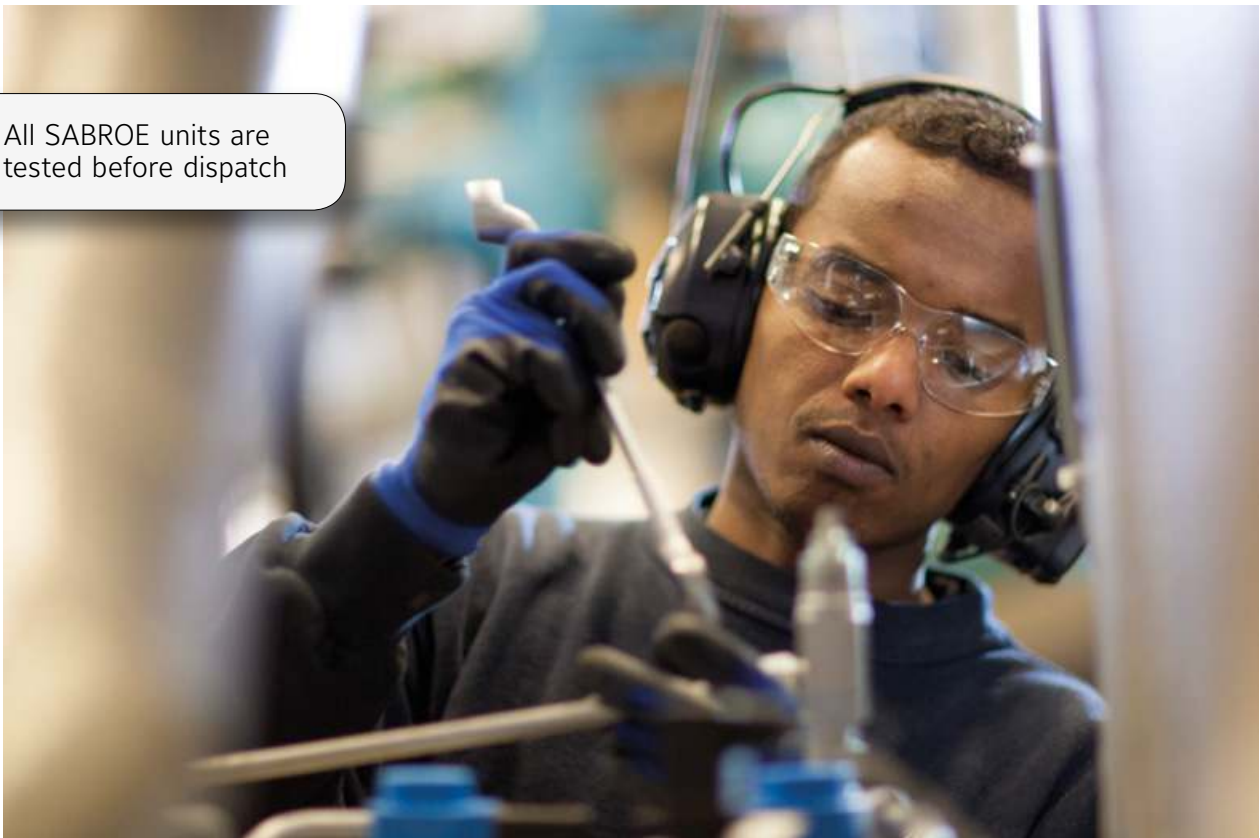

Testing in the factory – not on site

The unique SABROE End-of-Line (EOL) Test Centre, located in Denmark, is a purpose-built facility comprehensively equipped with state-of-the-art monitoring and testing equipment.

We can conduct a comprehensive range of tests, ranging from full-blown Factory Acceptance Tests (FAT) to any specific test package you may prefer. You and your staff are, of course, welcome to witness every stage of tests and trial runs to make sure everything performs as intended, with no unwelcome surprises.

Documented capabilities

Rigorous pre-commissioning testing gives you comprehensive, reliable documentation of the performance and capabilities of the exact equipment you'll be receiving – not just generic approximations.



Solid, dependable documentation helps you and your technical staff plan effective implementation and integration with other equipment. And all the pre-delivery tests help save you time, money and hassle with commissioning and running in. With SABROE product deliveries, you get what you ordered – and it works as you expected.



Test stands in the End-of-Line Test Centre

The SABROE brand has been in this business ever since 1897 – and development continues

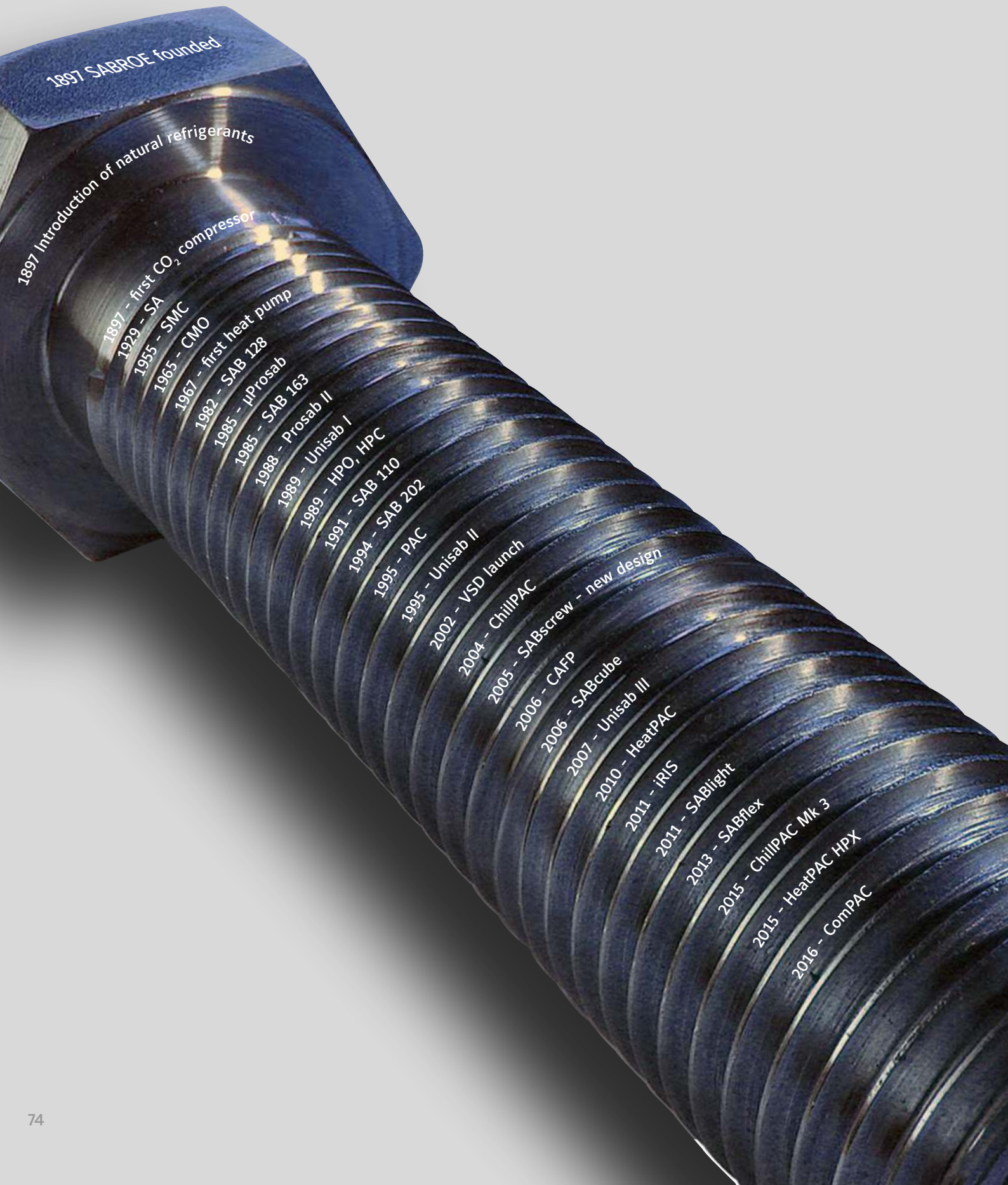

We have proved we can repeatedly and consistently deliver on our customers' needs – no matter how big and complex, or how small and sensitive.

We listen to what your real challenges are, and what you really want. And then we focus more than a century of specialist know-how on how best to achieve it.



Your local representative



Johnson Controls Denmark ApS
SABROE Factory
Christian X's Vej 201 · 8270 Højbjerg
Denmark
Phone +45 87 36 70 00
Fax +45 87 36 70 05
www.sabroe.com

