

MAT

Cold Store Air Curtain

Biddle



OPTIMAL CLIMATE SOLUTION FOR COLD STORES

The MAT air curtain is used for climate separation between the cold store and the loading area in order to keep the temperature at a constant level in the cold store. Furthermore it allows unobstructed access to and from the cold store, radically reducing misting and icing and provides an energy saving solution.

STABLE CLIMATE IN COLD AREA

The excellent climate separation abilities of the MAT air curtain prevent warm moist air from entering the cold store, which will decrease icing of the walls, floors and ceilings. Drivers of forklift trucks have an unobstructed view so traffic and pedestrians are immediately visible. This not only makes loading and unloading much faster, the safety of staff is increased as well as a reduction of slip hazards. With the Biddle cold store air curtain, the door can remain open constantly, so that logistics operations can be performed efficiently.

FEATURES AND BENEFITS:

EASY ACCESS & FAST LOGISTICS

- 🕒 Increased safety
- 🕒 Reduced icing on the floor
- 🕒 Reduced misting in the door opening
- 🕒 Faster loading and unloading

STABLE CLIMATE IN COLD AREA

- 🕒 Optimal climate separation (due to three air streams)
- 🕒 Reduced moisture transfer and therefore icing on ceilings/floor
- 🕒 Improved hygiene (HACCP guidelines)

ENERGY SAVING SOLUTION

- 🕒 Re-use of energy: high savings (hybrid solution)
- 🕒 Reduced load on cooling equipment

FULL-SCALE SERVICE

- 🕒 Full on-site survey
 - 🕒 Assistance with installation and commissioning
-

ENERGY SAVING SOLUTION

Use of a standard electrical cold store air curtain may yield energy savings of up to 80% compared with an open door. By applying a MAT Hybrid unit, the available waste heat from cooling machines is re-used, which leads to even greater energy savings.

APPLICATIONS

The MAT air curtains are suitable for door heights up to 4m in cold stores of factories, logistic centres, storage rooms and warehouses.

RECTIFIER TECHNOLOGY

When a door is open, the difference between the outside and inside temperature leads to an exchange of air, resulting in warm air entering and cold air flowing out. A cold store air curtain above the open door provides separation of the two climates. The MAT is equipped with the patented rectifier.

This outlet grille ensures the turbulent air coming from the fans is transformed into a laminar air stream. The air curtains outlet air stream reaches the floor at a much lower air speed than air curtains without the rectifier. The result is a climate separation efficiency of over 90%.

HOW IT WORKS

The MAT can be configured to be suitable for various heating sources including electrical heating and hybrid models (combined water & electrical heating source).

MULTI AIR STREAM TECHNOLOGY

Biddle has developed a sophisticated technology for cold stores with temperature differences of up to 30 to 40°C with the adjoining area. The Multi Air stream Technology forms the basis for the MAT cold store air curtain. By producing three air streams

the MAT creates a screen between the cold store and the ambient space. If the cold store is open all day, ambient air from the loading bay and cold air remain strictly separated. This prevents icing, misting and ensures a constant climate in the cold store.

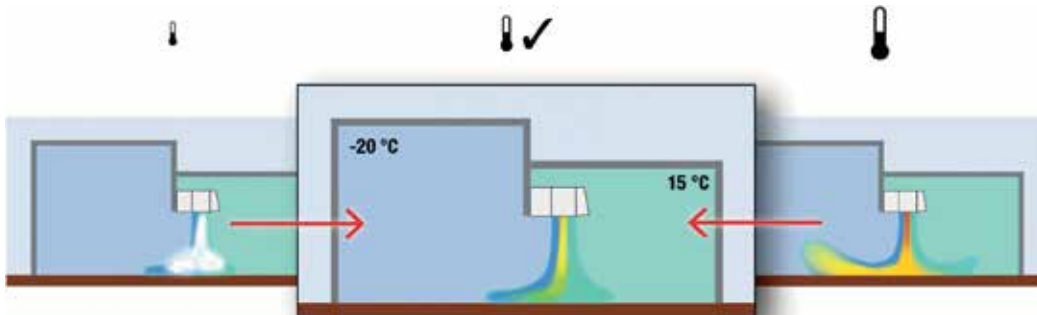

The automatic control of the B-stream always ensures the correct setting of the MAT (temperature & humidity)

AUTOMATIC CONTROL OF THE B-STREAM

The MAT air curtain is installed in the adjoining area above the door opening to the cold store. By producing three air streams the MAT creates a screen between the cold store and the loading area. It draws air from both the cold store (stream C) and the adjoining room (stream A), discharging both cold and warm air into the doorway. The outer two streams are quite different in

terms of temperature and absolute humidity. This can lead to condensation (misting) where the streams meet (1). To prevent condensation a middle stream is added (stream B) which is also taken from the cold store and subsequently heated resulting in a low relative humidity. The B-stream temperature depends mainly on the temperature and humidity of the adjoining area.

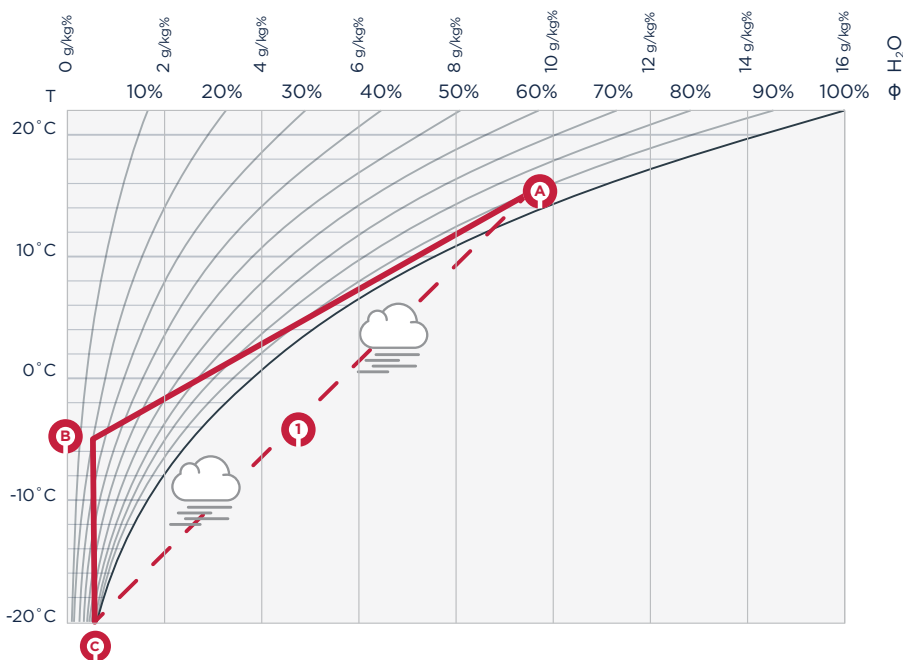

MOLLIER DIAGRAM:
A = loading area
B = middle stream
C = cold store
1 = misting

The B-stream can absorb moisture from the 'warm humid' A-stream so the A-stream and C-stream do not directly intermix and therefore not cause misting (see red line.)

INTELLIGENT CONTROL

The intelligent integrated control of the MAT air curtain ensures that the discharge temperature of the middle air stream is adjusted automatically based on the temperature and humidity in the adjoining area measured by various sensors. As a result the heating capacity of the air curtain is kept as low as possible in all conditions. A mist-free passage is guaranteed, while the energy use is minimised automatically.



MAT off: high exchange of air



MAT on: perfect climate separation

SOLUTIONS FOR COLD APPLICATIONS

POSSIBILITIES

- Free-hanging model
- Door height: 2.5 - 4 m
- Unit length: 135 - 180 - 225 - 250 cm
- Maximal 2 MAT units per door (master & slave)
- Electrical supply: 400V

HEATING SOURCE

- Electrical heating (E)
- Electrical heating with extra heating capacity (EE)
- Hybrid (H4E): combined water & electrical heating coil

CONTROL

- Automatic control (B-stream)
- 1 control panel for master & slave unit

STANDARD COLOUR

- Stainless steel

MOUNTING FRAME (not delivered by Biddle)

- Corridor (incl. isolating construction at the sides)
- Protection bar

The corridor is essential for a good performance of the MAT cold store air curtain. For an optimal climate separation it is important that the corridor is air-tight everywhere. To protect the MAT air curtain against collisions a protective bar is recommended.

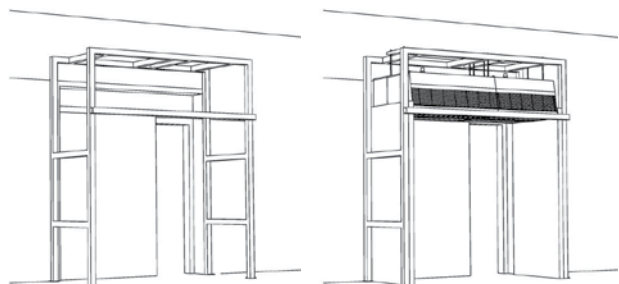

Corridor incl. MAT air curtain, mounting frame & protection bar (picture right)



CONTROLS

With one control panel a master and slave unit can be controlled. The MAT air curtain can cover a maximum door width of 5 meters.

BENEFITS

- ⊖ For large temperature differences between areas
- ⊖ Always the correct setting
- ⊖ No misting & icing
- ⊖ Constant climate in the cold store
- ⊖ Energy saving solution
- ⊖ No turbulences in the air stream
- ⊖ Control of two units (master / slave)

OPERATING PACKAGE AUTOMATIC CONTROL:

- ⊖ Automatic control (B-stream)
- ⊖ Door contact switch
- ⊖ Water-side control (in case of hybrid version)
- ⊖ 2 x Biddle low-voltage cable (35 m)

Optional:

- ⊖ RCM-module (hybrid version) optional after 3 months
- ⊖ 1 or 2 alert lights



ENERGY SAVING HYBRID SOLUTION

Energy saving solutions are becoming of great importance in the industrial and cold sector. In order to meet this trend Biddle has developed the MAT Hybrid, which makes use of waste heat of cooling machines in order to save energy. In practice up to 80% energy savings have been measured by applying the MAT Hybrid model compared to an equivalent electrical unit.

HOW IT WORKS

The MAT Hybrid consists of a combined water and electrical heating element. First, the heat available from the water is used to its maximum. Then, when necessary, the electrical element will automatically assist the water coil, thus always ensuring the required discharge B-stream temperature. The interaction between the water and electric element ensures optimal climate separation, making the benefits of the MAT also apply to the Hybrid version.

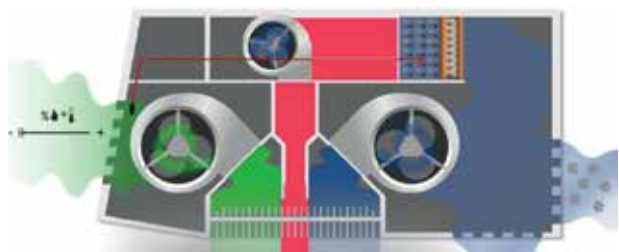

MAT Hybrid: combined water & electric element

REMOTELY MONITORED

A constant water flow is a requirement for the proper functioning of the MAT Hybrid. As a standard this is monitored for three months in order to guarantee a reliable solution. By means of the RCM-module (Remote Control Monitoring module) the water flow is monitored remotely. The customized online dashboard visualises how the MAT Hybrid performs in practice. When necessary, adjustments can be made to optimise it.

VARIOUS MONITORING OPTIONS

- Air inlet temperature of electrical and water heating coil
- Temperature and humidity of ambient area
- Temperature A-stream
- Discharge temperature B-stream
- Air inlet temperature C-stream
- Pressure difference B-stream
- Actual fan speed Return water temperature of heating coil
- Contribution of electrical heating (% of installed heating capacity)

RCM-MODULE: OPTIONS AFTER THREE MONTHS

A Remote Control Monitoring-module is required for three months to guarantee a stable water flow of the MAT Hybrid. There are four options after three months:

- Biddle monitors the MAT Hybrid, reacts on error reports and gives feedback every month for an optimal operation
- Biddle reacts on error reports
- The customer monitors the MAT Hybrid, takes over the module and online subscription (Biddle can support when needed)
- No monitoring requested

MAT HYBRID IN PRACTICE

The MAT Hybrid was monitored in a well-known logistic warehouse for three months and its performance was compared to an equivalent electrical unit.

COLD STORE INFORMATION:

- Size of the door: 2.70 x 3 m (width x height)
- 2 x MAT 135 (master & slave)
- Temperature cold store: - 24°C
- Temperature ambient area: 6°C

RESULTS:

- Heating capacity decreased by 32 kW
- Yearly energy use decreased 156000 kWh
- Yearly costs decreased by €22.000

BENEFITS MAT HYBRID:

- Energy savings of 80% compared to an electrical unit
- Reliable and stable solution
- Optimal climate separation
- Remotely monitored

SPECIFICATIONS

CASING

The MAT unit is delivered as a standard in stainless steel (AISI 304).

MOTOR / FAN ASSEMBLY

The unit is equipped with dual-inlet, vibration free suspended centrifugal fans. Each fan is driven by a two-sided, suspended rotor motor on ball bearings. The fan casing and the impeller are made of zinc coated plate steel. The motors are, as a standard, fitted with thermal contacts. These thermal contacts will break the circuit of the motor when the maximum permissible motor temperature is exceeded.

HEATING COIL

The electrical heating coil is made up of rod elements. The coil is controlled by the electronic control unit and is fitted with overload protection. The high efficient heating coils of the Hybrid model are made of 3/8" copper pipes and aluminium fins. The water connections are G 1". These connections are located on the top of the unit.

STANDARD DELIVERY:

Control unit (incl. control panel)
Suspension frame (M12 threaded rods not delivered)
RCM-module (hybrid version) for the first 3 months

ELECTRICAL CONNECTIONS

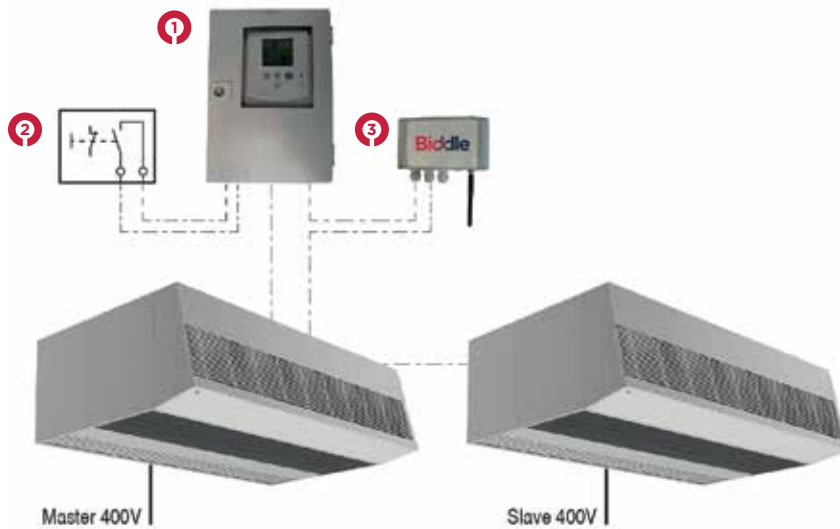

- 1 Control unit
- 2 Door contact switch
- 3 RCM-module (in case of hybrid version)

MAT

Technical Details



MAT 135-E

Unit length	m	1.35			
Door height	m	2.5 - 4			
Electrical supply	V/ph/Hz	400/3N/50			
Max. input current	A	5			
Max. current consumption (3 phase)	A	39			
Max. input power	kW	3.15			
Max. power consumption	kW	27			
Max. heating capacity - electric	kW	23.6			
Weight	kg	320			
Speed		1	2	3	4
Air volume	m ³ /h	8505	9720	10935	13365

MAT 135-EE

Unit length	m	1.35			
Door height	m	2.5 - 4			
Electrical supply	V/ph/Hz	400/3N/50			
Max. input current	A	5			
Max. current consumption (3 phase)	A	54			
Max. input power	kW	3.15			
Max. power consumption	kW	37			
Max. heating capacity - electric	kW	33.8			
Weight	kg	320			
Speed		1	2	3	4
Air volume	m ³ /h	8505	9720	10935	13365

MAT 180-E

Unit length	m	1.80			
Door height	m	2.5 - 4			
Electrical supply	V/ph/Hz	400/3N/50			
Max. input current	A	6.7			
Max. current consumption (3 phase)	A	52			
Max. input power	kW	4.2			
Max. power consumption	kW	36			
Max. heating capacity - electric	kW	31.5			
Weight	kg	416			
Speed		1	2	3	4
Air volume	m ³ /h	11340	12960	14580	17820

MAT 180-EE

Unit length	m	1.80			
Door height	m	2.5 - 4			
Electrical supply	V/ph/Hz	400/3N/50			
Max. input current	A	6.7			
Max. current consumption (3 phase)	A	72			
Max. input power	kW	4.2			
Max. power consumption	kW	49			
Max. heating capacity - electric	kW	45			
Weight	kg	416			
Speed		1	2	3	4
Air volume	m ³ /h	11340	12960	14580	17820

MAT 225-E

Unit length	m	2.25			
Door height	m	2.5 - 4			
Electrical supply	V/ph/Hz	400/3N/50			
Max. input current	A	8.4			
Max. current consumption (3 phase)	A	65			
Max. input power	kW	5.25			
Max. power consumption	kW	45			
Max. heating capacity - electric	kW	39.4			
Weight	kg	513			
Speed		1	2	3	4
Air volume	m ³ /h	14175	16200	18225	22275

MAT 225-EE

Unit length	m	2.25			
Door height	m	2.5 - 4			
Electrical supply	V/ph/Hz	400/3N/50			
Max. input current	A	8.4			
Max. current consumption (3 phase)	A	90			
Max. input power	kW	5.25			
Max. power consumption	kW	62			
Max. heating capacity - electric	kW	56.3			
Weight	kg	513			
Speed		1	2	3	4
Air volume	m ³ /h	14175	16200	18225	22275

MAT 250-E

Unit length	m	2.50			
Door height	m	2.5 - 4			
Electrical supply	V/ph/Hz	400/3N/50			
Max. input current	A	8.4			
Max. current consumption (3 phase)	A	65			
Max. input power	kW	5.25			
Max. power consumption	kW	45			
Max. heating capacity - electric	kW	39.4			
Weight	kg	552			
Speed		1	2	3	4
Air volume	m ³ /h	14175	16200	18225	22275

MAT 250-EE

Unit length	m	2.50			
Door height	m	2.5 - 4			
Electrical supply	V/ph/Hz	400/3N/50			
Max. input current	A	8.4			
Max. current consumption (3 phase)	A	90			
Max. input power	kW	5.25			
Max. power consumption	kW	62			
Max. heating capacity - electric	kW	56.3			
Weight	kg	552			
Speed		1	2	3	4
Air volume	m ³ /h	14175	16200	18225	22275

MAT 135 HYBRID

Unit length	m	1.35			
Door height	m	2.5 - 4			
Electrical supply	V/ph/Hz	400/3N/50			
Max. input current	A	5			
Max. current consumption (3 phase)	A	29			
Max. input power	kW	3.15			
Max. power consumption	kW	20			
Max. heating capacity - electric	kW	16.9			
Weight	kg	325			
Water range	°C	40/30			
Speed		1	2	3	4
Air volume	m ³ /h	8505	9720	10935	13365
Air volume B-stream	m ³ /h	1700	1945	2185	2675
Air inlet temperature	°C	-20			
Heating capacity - water	kW	20.4	22.2	23.9	27
Water flow rate	l/h	1859	2026	2181	2463
Water pressure drop with 2 & 3-port valve	kPa	17	19.9	22.8	28.7

MAT 180 HYBRID

Unit length	m	1.80			
Door height	m	2.5 - 4			
Electrical supply	V/ph/Hz	400/3N/50			
Max. input current	A	6.7			
Max. current consumption (3 phase)	A	39			
Max. input power	kW	4.2			
Max. power consumption	kW	27			
Max. heating capacity - electric	kW	22.5			
Weight	kg	424			
Water range	°C	40/30			
Speed		1	2	3	4
Air volume	m ³ /h	11340	12960	14580	17820
Air volume B-stream	m ³ /h	2270	2590	2915	3565
Air inlet temperature	°C	-20			
Heating capacity - water	kW	25.9	28.2	30.3	34.2
Water flow rate	l/h	2366	2575	2770	3125
Water pressure drop with 2 & 3-port valve	kPa	12.3	14.5	16.7	21.1

MAT 225 HYBRID

Unit length	m	2.25			
Door height	m	2.5 - 4			
Electrical supply	V/ph/Hz	400/3N/50			
Max. input current	A	8.4			
Max. current consumption (3 phase)	A	49			
Max. input power	kW	5.25			
Max. power consumption	kW	33			
Max. heating capacity - electric	kW	28.1			
Weight	kg	523			
Water range	°C	40/30			
Speed		1	2	3	4
Air volume	m ³ /h	14175	16200	18225	22275
Air volume B-stream	m ³ /h	2835	3240	3645	4455
Air inlet temperature	°C	-20			
Heating capacity - water	kW	34.3	37.3	40.2	45.5
Water flow rate	l/h	3128	3410	3673	4154
Water pressure drop with 2 & 3-port valve	kPa	22.5	26.5	30.6	38.8

MAT 250 HYBRID

Unit length	m	2.50			
Door height	m	2.5 - 4			
Electrical supply	V/ph/Hz	400/3N/50			
Max. input current	A	8.4			
Max. current consumption (3 phase)	A	49			
Max. input power	kW	5.25			
Max. power consumption	kW	33			
Max. heating capacity - electric	kW	28.1			
Weight	kg	563			
Water range	°C	40/30			
Speed		1	2	3	4
Air volume	m ³ /h	14175	16200	18225	22275
Air volume B-stream	m ³ /h	2835	3240	3645	4455
Air inlet temperature	°C			-20	
Heating capacity - water	kW	36.3	39.6	42.8	48.5
Water flow rate	l/h	3311	3618	3905	4432
Water pressure drop with 2 & 3-port valve	kPa	25.9	30.7	35.6	45.4

MAT ELECTRIC & HYBRID

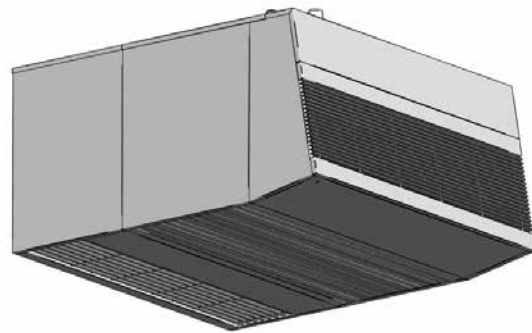
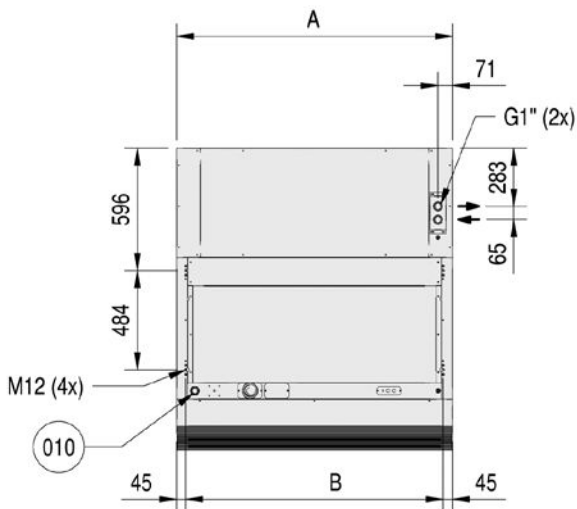

10 - Cable feed through

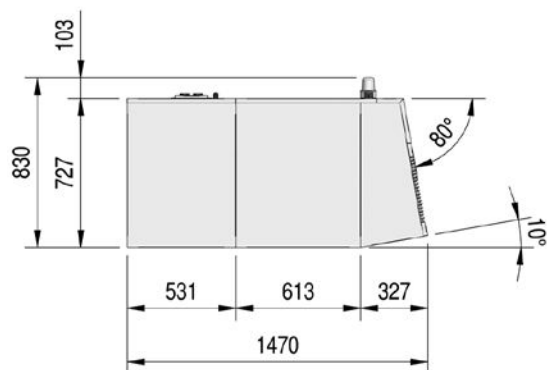
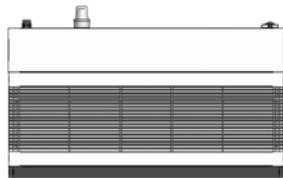

	A	B
MAT 135 - ...	1352	1262
MAT 180 - ...	1802	1712
MAT 225 - ...	2252	2162
MAT 250 - ...	2502	2412

BIDDLE AIR SYSTEMS

St. Mary's Road
Nuneaton
Warwickshire
CV11 5AU

T +44 (0) 2476 384 233

E sales@biddle-air.co.uk

www.biddle-air.co.uk



Biddle

Every effort has been made to ensure descriptions are correct at the time of print.
Errors and omissions excepted. MAT|V1|06|2019