

FR-TERM A.Ş. 1979 yılında İstanbul'da kurulmuştur. Ticari soğutma, endüstriyel soğutma ve klima sektöründe projelendirme, imalat, taahhüt ve satış işleri yaparak tecrübe ve bilgi birikimi oluşturmaktadır.

Süreç içinde geniş yelpazedeki faaliyet alanını daraltmış ve kanatlı borulu siflanjörlerinde uzmanlaşarak Hava Soğutmalı Kondenseler, Soğuk Oda Evaporatörleri, Kuru Soğutucular, Sulu/Buharlı Hava Isıtıcı ve Soğutucular, Yağ Soğutucular ile Isı Geri Kazanım Bataryalarının üretimine odaklanmıştır.

FR-TERM A.Ş. İstanbul Tuzla'da 11.000 m<sup>2</sup> kapalı alana sahip iki üretim tesisi ve 230 yetkin personeli, modern makina ve donanım ile sektörün hizmetindedir.

FR-TERM A.Ş. faaliyet alanındaki liderliğini ISO 9001:2000 Kalite Güvence Sistemini RW-TÜV'den sertifikalandırarak sürdürmenin gururunu tüm müşterileri ile paylaşmaktadır.

FR-TERM tarafından geliştirilen batarya seçim yazılımı COILS 5.5 FRT1, Sulu Hava Isıtma ve Soğutma Bataryaları için EUROVENT sertifikalıdır ve performans onaylıdır.

Tüm FRITERM ürünleri ilgili Avrupa yeni yaklaşım direktiflerine uygun olarak üretilmektedir. Ürünlerin CE ifaletmesi onaylı kuruluş TÜV Product Service - Stuttgart tarafından denetlenmiştir.

Ayrıca, Rusya Federasyonu ve BDT (Bağımsız Devletler Topluluğu) ülkelerine yapılan ihracatlarda zorunlu olan GOST belgelendirilmesi tüm FR-TERM ürünleri için tamamlanmıştır.

FR-TERM A.Ş. mutlak müşteri memnuniyetini esas almakta, Araştırma - Geliştirme ve özgün tasarımı önem vererek ürünlerinde fark yaratmaktadır.

FR-TERM A.Ş. kalite politikasını "Topluma ve çevreye duyarlı, müşteri memnuniyetini en üst düzeyde karşılayacak, kaliteli, ekonomik ürün ve hizmeti zamanında sunan lider bir takım olmak" olarak ortaya koymuştur.

FR-TERM A.Ş. was founded in 1979. In the first years, the company has worked as contractor for the applications of various industrial cooling, commercial cooling and air-conditioning projects.

In the meantime, FR-TERM has specialized on finned type heat exchangers and focused on the production of Air Cooled Condensers, Air Coolers, Dry Coolers, Water/Steam Air Heaters and Coolers, Oil Coolers and Heat Recovery Coils.

FRITERM is working for the AC and Refrigeration markets with its two production plants having 11.000 m<sup>2</sup> closed area in Tuzla - İstanbul with 230 qualified and experienced staff and modern machinery park.

As being one of the leading manufacturers of finned type exchangers, FRITERM meets the quality requirements of international markets.

Quality management system of FRITERM has been certified by RW-TÜV with ISO 9001:2000 Certification.

COILS 5.5 FRT 1, the coil selection software developed by FR-TERM, is certified by EUROVENT for Air Heating and Cooling Coils Using Water.

As well, all FRITERM products are according to relevant European new approach directives and have CE marking which the corresponding tests have been carried out by TÜV Product Service - Stuttgart.

Furthermore, FRITERM products have GOST Certification for export to Russian Federation and CIS (Commonwealth of Independent States).

FRITERM takes absolute customer satisfaction as the basis of its mission. Thanks to qualified and skillful Research & Development team FRITERM makes difference in its products by original designs and optimum solutions.

Quality policy of FRITERM is "To be a leading team which provides high quality, economic products and service with precise delivery time, meeting full customer satisfaction while being environment friendly".

Die FRITERM A.S. ist 1979 in Istanbul gegründet worden. Sie hat Kenntnisse, Wissen und Erfahrung bei der Produktion gewerblicher und industrieller Kühler- und Klimasysteme und durch kaufmännische Tätigkeiten gesammelt.

Mit der Zeit hat sie ihr breites Tätigkeitsfeld auf die Produktion von Wärmetauschern mit Flügelrohren, Verdampfer für Kühlräume, Trockenkühler, Kühler und Wärmeerzeuger mit Wasser/Dampf und Wärmerückgewinnungsbatterien konzentriert.

Die FRITERM A.S. ist mit ihren Produktionsanlagen in Tuzla/Istanbul mit einer geschlossenen Gesamtfläche von 11.000 qm, 230 qualifizierten Mitarbeitern, modernen Maschinen und Ausrüstungen ständig im Dienst am Kunden.

Die FRITERM A.S. ist stolz darauf, daß ihre Kunden sie erneut als führendes Unternehmen in der Kälte- und Klimabranche bestätigt haben. Insbesondere deshalb, weil FRITERM A.S. die Zertifikate über ihr Qualitätssicherungssystem ISO 9001:2000 vom RW-TÜV erhalten hat.

Die FRITERM A.S. hat für das selbst entwickelte Berechnungsprogramm „COILS 5.5 FRT-1“ für Luft-/Wasser-/Wärmetauscher das EUROVENT-Zertifikat erhalten.

Alle FRITERM-Produkte werden gemäß den neuen Regeln der EU-Richtlinien produziert. DIE CE-Markierung der Produkte sind vom TÜV Product Service Stuttgart kontrolliert worden.

Außerdem ist die internationale GOST-Zertifizierung der FRITERM-Produkte für den Export in die Russische Föderation und in die Gemeinschaft Unabhängiger Staaten erfolgreich abgeschlossen.

Die Besonderheit unserer Produkte besteht in der eigenen Forschung und Entwicklung sowie dem originellen Design.

Unser Ziel ist die Zufriedenheit unserer Kunden und damit die Sicherstellung unserer Führungsrolle auf dem Markt hinsichtlich Qualität, Umweltverträglichkeit, gutem Service und Pünktlichkeit.



EN ISO 9001: 2000  
Reg. No: 04100 20054602-EE



ID NO: COILS-02-04-001/002/003/004



EN ISO 9001: 2000  
Reg. No: 04100 20054602-EE



ID NO: COILS-02-04-001/002/003/004



EN ISO 9001: 2000  
Reg. No: 04100 20054602-EE



ID NO: COILS-02-04-001/002/003/004



Not : Katalogdaki değerlerin müşteriye haber vermeden değiştirilme hakkı tarafımızdan saklı tutulmaktadır.

P.S. : Friterm reserves the right to make modifications in the catalog at any time without prior notice.

Vermerk : Wir behalten uns das Recht vor, die Werte aus dem Katalog ohne vorherige Mitteilung an die Kunden zu ändern.

01.10.2005

Merkez : Head Office	Organize Deri Sanayi Bölgesi 18. Yol 34957 Tuzla, İstanbul / Türkiye Tel : +90 (216) 394 12 82 (pbx) Fax: +90 (216) 394 12 87 E-mail : info@friterm.com Web : http://www.friterm.com
İzmir Ort. Bürosu Branch Office	İnönü Caddesi Çarşısı - İl Hanı No: 69 Kat: 3 Daire: 306 35110 Yenifehir, İzmir / Türkiye Tel : +90 (232) 458 96 93 Fax: +90 (232) 458 96 94 E-mail : izmirbolge@friterm.com

## İFİ OK DONDURUCULAR BLAST FREEZERS SCHOCKFROSTER

6.2 kW ÷ 56,7 kW



### TEKNİK BİLGİLER

#### ÖZELLİKLER VE UYGULAMA

- H serisi, S serisi, T serisi ve K serisi olmak üzere 4 tipte üretilen FRITERM fi ok Dondurucular, -35°C oda ve -40°C evaporasyon şartlarında, 6,2 kW - 56,7 kW gibi geniş bir kapasite aralığına sahiptir.
- Lamel aralığı tüm modeller için 12 mm'dir
- Devreleme, floklama uygulamalarının bir gereği olarak çok düşük akışkan basınçlarına uygun olacak şekilde tasarlanmıştır.
- fi ok Dondurucular, kendi genliğinde oda içinde 3-6 m/sn serbest hava hızı elde edilecek şekilde dizayn edilmiştir.
- Batarya devresi R 404A ve R 22 soğutucularına uygun düzenlenmiştir.
- Kapasiteler R 404A için verilmiştir.

#### Compact and highly efficient coils have these features:

- Aluminium fins,
- 5/8" çapında bakır borulu batarya,
- Girifli çukurluk bağlantıları yan kısımdadır.
- Soğutucu distribütörü,
- Test basıncı: 34 bar
- Maksimum işletme basıncı: 21 bar,
- Pozitif Basınç altında sevk,
- Basınç kontrol sübabı,
- Az soğutucu harcı gerektiren devreleme.

#### KASETLEMELER

- Kasetlemede, elektrostatik toz boyalı galvaniz ve paslanmaz sac seçenekleri sunulmaktadır. Paslanmaz sac kasetli fi ok Dondurucular daha çok hijyenik ortamlarda kullanılmaktadır.
- Hava bypass kesen ara drenaj tavası uygulaması yapılmıştır.
- Çözümlenmiş çift cidarlı tava standart olarak kullanılmaktadır.
- S ve H serilerinde Fan bölümü, batarya bölümünden ayrılabilir.
- Çelik ayaklar taşıma sırasında ürünün yerini uygun şekilde konmasını kolaylaştırır.

#### FANLAR

- Ø630 ve Ø710 mm kanat çapında, trifaze (400 V AC, 50 Hz, 1400 d/d) yüksek verimli ve yüksek basınçlı Ziehl-Abegg veya muadil fanlar kullanılmaktadır.
- Motor koruması IP 54, izolasyon sınıfı F
- Çalışma aralığı: -40°C / +60°C
- Kapalı tipte yağlamasız motor
- Emniyet standardına uygun fan koruması
- Fan bölümü, nakliyat ve yerleştirme esnasında ihtiyaç duyulursa sökülüp takılabilir.

#### DEFROST

- fi ok Dondurucularında elektrikli defrost sistemi kullanılmaktadır. Batarya, Drenaj tavası, fan ve drenaj hattı defrost sistemi standarttır. Bu sistem sayesinde defrost sırasında ortaya çıkan su kolay bir şekilde tahliye edilebilmektedir.
- Özel dizayn sulu defrost uygulaması yapılabilir.

### TECHNICAL SPECIFICATIONS

#### FEATURES AND APPLICATION

- FRITERM Blast Freezers, including H series, S series, T series and K series, are designed to meet all needs of blast freezing applications from 6,2 kW to 56,7 kW based on -35°C room and -40°C evaporation conditions.
- Fin spacing is 12 mm for all model.
- Circuit design is appropriate for very low fluid pressure drop which is must in blast freezing applications.
- Blast Freezers designed for 3-6 m/s free air velocity in freezing room.
- The coil circuits designed for refrigerants R 404A and R 22.
- Capacities valid for R 404A.

#### Compact and highly efficient coils have these features:

- Aluminium fins,
- 5/8" copper tubes in coils,
- Inlet and outlet connections are on the left side as standard.
- Refrigerant distributor,
- Test pressure: 34 bar,
- Maximum operating pressure: 21 bar,
- Delivered under positive pressure,
- Schrader valve,
- Low refrigerant charge required circuit design.

#### CASING

- Electrostatically powder painted galvanized steel is used for casing, and stainless steel as an option, which is especially used for hygienic needs.
- Intermediate drain pan prevents air bypass.
- Insulated double skin drain pan are used as standard.
- Fan block of Blast freezer can be mounted separately from the coil side for H and S series.
- Steel support legs make it possible to place the good on the ground appropriately during transportation.

#### FANS

- Fans ZIEHL-ABEGG brand or equivalent in Ø630 - Ø710 mm diameters. (400 V AC, 50 Hz, 1400 rpm)
- IP 54 motor protection and F class insulation.
- Working conditions -40°C / +60°C.
- Lubrication-free closed type motors.
- Fan guards according to safety standards.
- Fan block can be demounted if needed for transport and installation reasons.

#### DEFROST

- Electrical defrost heaters applied to FRITERM Blast Freezers. Coil, Drain Tray, Fan and Drain Line defrost heaters are standard. In this system, condense water can be drained easily by insulated drain pan and drain line heaters.
- Special design water defrost system is optional.

### TECHNISCHE ANGABEN

#### SPEZIFIKATIONEN UND ANWENDUNG

- Die in vier Typen der Serien H, S, T und K hergestellten Schockfroster von FRITERM haben unter den -35 °C Raum- und -40 °C Verdampfungstemperaturbedingungen einen Leistungsbereich von 6,2 kW – 56,7 kW.
- Lamellenabstand 12 mm
- Es wurde ein Kreislaufsystem entwickelt, um bei sehr niedrigem Flüssigkeitsdruckbereich (Schockfrosteranwendung) eine optimale Leistung zu erreichen.
- Die Schockgefrier-Verdampfer nehmen die gesamte Breite des Gefrierraums ein, wodurch eine Freiluftgeschwindigkeit von 3-6 m/sek erreicht werden kann.
- Der Kreislauf des Lamellenblocks wurde für die Kältemittel R 404A und R 22 optimiert.
- Leistungsangaben gelten für R 404A.

#### Eigenschaften der Hochleistungsblöcke:

- Lamellen aus Aluminium,
- Block mit Kupferrohr Ø 5/8",
- Seitliche Ein- und Austrittsverbindungen
- Kältemittelverteiler,
- Testdruck: 34 Bar,
- max. Betriebsdruck: 21 Bar,
- Lieferzustand mit positivem Schutzgasfüllung,
- Schraderventil am Austritt,
- Wärmetauscher mit geringem Innenvolumen.

#### GEHÄUSE

- Das Gehäuse wird in zwei Ausführungen angeboten: aus pulverbeschichtetem, verzinkten Stahlblech oder aus Edelstahl. In Hygienebereichen werden überwiegend Edelstahlgehäuse angewendet.
- Eine Tropfschale mit Staubblech zur Vermeidung von Kondenswasserbildung.
- Zur Standardausführung gehört eine isolierte Wanne mit Doppelwand.
- Bei den Serien S und H kann der Lüfter vom Lamellenblock getrennt werden.
- Optimale Aufstellung und Montage des Produkts dank Stahlfüßen

#### VENTILATOREN

- Hier werden Drehstrom-Hochleistungsventilatoren (400 V AC, 50 Hz, 1400 upm) von Ziehl-Abegg mit Flügel durchmessern von 630 und 710 mm oder vergleichbaren Ventilatoren eingesetzt.
- Motorschutzart ist IP 54. Isolierklasse F.
- Einsatzbereich -40 °C / +60 °C
- Geschlossener, wartungsfreier Motor
- Mit Berührungsschutzgitter.
- Die Lüftereinheit kann bei Bedarf während des Transports und der Aufstellung abmontiert werden.

#### ABTAUEN

- Die Schockfroster-Verdampfer sind mit elektrischem Abtausystem ausgerüstet. Das elektrische Abtausystem für Lamellenblock, Tropfwanne, Ventilator und Ablaufleitung ist standard. Durch dieses System kann das Tauwasser sehr leicht entfernt werden.
- Sonderdesign für das Wasserabtauen ist möglich.

### TEKNİK BİLGİLER

#### KAPASİTE STANDARTLARI

Akışkan	: R 404 A
Oda Sıcaklığı	: - 35 °C
Evaporasyon Sıcaklığı	: - 40 °C
T= 5 °C	
Kondenzasyon Sıcaklığı	: 40 °C
Rakım	: 0 m

### TECHNICAL SPECIFICATIONS

#### CAPACITY STANDARDS

Refrigerant	: R 404 A
Room Temperature	: - 35 °C
Evaporation Temperature	: - 40 °C
T= 5 °C	
Condensation Temperature	: 40 °C
Altitude	: 0 m

### TECHNISCHE ANGABEN

#### LEISTUNGSNORMEN

Kältemittel	: R 404 A
Raum Temperatur	: - 35 °C
Verdampfungstemperatur	: - 40 °C
T= 5 °C	
Verflüssigungstemperatur	: 40 °C
Aufstellungsorte	: 0 m

#### KAPASİTE DÜZELTME FAKTÖRÜ (f1) • CAPACITY CORRECTION FACTOR (f1) • KORREKTUR FAKTOR FÜR LEISTUNG (f1)

Oda Sıcaklığı Room Temperature Raum Temperatur °C	T (Oda Sıcaklığı - Evaporasyon Sıcaklığı) (Room Temperature - Evaporation Temperature) °C (Raum Temperatur - Verdampfungstemperatur)					
	5	6	7	8	9	10
-35	1,00	1,20	1,40	1,60	1,80	2,00
-40	0,98	1,18	1,37	1,57	1,76	1,96

$$Q_{NK} = \left( \frac{Q_R}{f1} \right)$$

Q<sub>NK</sub> : Nominal Katalog Kapasitesi  
Nominal Catalog Capacity  
Katalog Nennleistung  
Q<sub>R</sub> : İstenen Kapasite  
Required Capacity  
Gewünschte Leistung  
f1 : Düzeltme Faktörü  
Correction Factor  
Korrektur Faktor

#### fi OK DONDURUCU SEÇİMİ

Q <sub>R</sub> İstenen Kapasite	14,5 kW
T1 Oda Sıcaklığı	- 40 °C
T2 Evaporasyon Sıcaklığı	- 46 °C
T Sıcaklık Farkı	6 °C
f1 Düzeltme Faktörü	1,18

$$Q_{NK} = \frac{Q_R}{f1} = \frac{14,5}{1,18} = \sim 12 \text{ kW}$$

Seçilen Ürün :

FSL 63.22 T (12,60 kW)  
FSL 63.21 S/H (13,30 kW)  
FSL 63.21 K (13,40 kW)

Bilgisayar kullanarak seçim yapmak için Windows altında çalışan "Friterm Standart Ürün Seçim Programı'nı" kullanınız.

#### BLAST FREEZER SELECTION

Q <sub>R</sub> Desired Capacity	14,5 kW
T1 Room Temperature	- 40 °C
T2 Evaporation Temperature	- 46 °C
T Temperature Difference	6 °C
f1 Correction Factor	1,18

$$Q_{NK} = \frac{Q_R}{f1} = \frac{14,5}{1,18} = \sim 12 \text{ kW}$$

Selected Air Cooler :

FSL 63.22 T (12,60 kW)  
FSL 63.21 S/H (13,30 kW)  
FSL 63.21 K (13,40 kW)

To make product selection by using computer, please use "Friterm Standard Product Selection Software" operating under Windows.

#### AUSWAHL DES SCHOCKFROSTER

Q <sub>R</sub> Gewünschte Leistung	14,5 kW
T1 Raum Temperatur	- 40 °C
T2 Verdampfungstemperatur	- 46 °C
T Temperaturunterschied	6 °C
f1 Korrektur Faktor	1,18

$$Q_{NK} = \frac{Q_R}{f1} = \frac{14,5}{1,18} = \sim 12 \text{ kW}$$

Ausgewählter Schockfroster :

FSL 63.22 T (12,60 kW)  
FSL 63.21 S/H (13,30 kW)  
FSL 63.21 K (13,40 kW)

Für die Auswahl über den Computer benutzen Sie bitte das "Standard - Produktauswahl - Programm von Friterm", welches unter Windows arbeitet.

#### ADLANDIRMA • CLASSIFICATION • KLASSIFIZIERUNG

Friterm fi ok Dondurucu  
Friterm Blast Freezer • Friterm Schockfroster

Fan Çapı (cm)  
Fan Diameter (cm) • Durchmesser (cm) (63: Ø630 / 71: Ø710)

Fan Sayısı  
Number of Fans • Anzahl der Ventilatoren

Tip  
Type • Typ

Seri (H / S / K / T)  
Series (H / S / K / T) • Serie (H / S / K / T)

S SERİSİ • S SERIES • S SERIE



H SERİSİ • H SERIES • H SERIE



fi OK DONDURUCU KAPASİTE TABLOSU • BLAST FREEZER CAPACITY TABLE • SCHOCKFROSTER LEISTUNGSTABELLE

Hatve Fin Spacing / Lamellenabstand	Model Model / Modell	Kapasite Capacity / Nenn-Leistung	Yüzey Surface / Oberfläche	Boru Hacmi Tube Volume / Rohrinhalt	Fanlar Fans / Ventilatoren					Defrost İş-t-c-leri Electric Defrost / Elektrische Abtaugung					
					Hava Debisi Air Flow / Luftmenge	Say-sı Number / Anzahl	Çap Diameter / Durchmesser	Güç Power / Leistung	Akım Current / Strom	Batarya Coil / Batterie	Yedek Spare / Vorrat	Drenaj Tavası Drain Pan / Tropfwanne	Yedek Spare / Vorrat	Fan Davlumbaz Yakası Fan Housing Collar Ventilatore	Drenaj Hattı Drain Line / Wasserablauf
mm		W	m <sup>2</sup>	dm <sup>3</sup>	m <sup>3</sup> /h	n	mm	W	A	W	W	W	W	W	W
12 mm	FSL 63.11 S/H	6600	44,6	19,70	16000	1	630	1900	3,2	10 x 450	5 x 450	2 x 450	450	1 x 300	300
	FSL 63.12 S/H	9100	67,0	29,55	15500	1	630	1900	3,2	14 x 450	7 x 450	2 x 450	450	1 x 300	300
	FSL 63.21 S/H	13300	89,3	39,40	32000	2	630	3800	6,4	11 x 850	5 x 850	2 x 850	850	2 x 300	300
	FSL 63.22 S/H	19100	133,9	59,09	31000	2	630	3800	6,4	15 x 850	7 x 850	2 x 850	850	2 x 300	300
	FSL 63.31 S/H	20900	133,9	59,09	48000	3	630	5700	9,6	11 x 1250	5 x 1250	2 x 1250	1250	3 x 300	300
	FSL 63.32 S/H	28800	200,9	88,64	46500	3	630	5700	9,6	16 x 1250	8 x 1250	2 x 1250	1250	3 x 300	300
	FSL 63.41 S/H	25600	178,6	78,79	64000	4	630	7600	12,8	10 x 1650	5 x 1650	2 x 1650	1650	4 x 300	300
	FSL 63.42 S/H	35900	267,9	120,20	62000	4	630	7600	12,8	15 x 1650	7 x 1650	2 x 1650	1650	4 x 300	300
	FSL 71.11 S	8500	55,7	24,62	19400	1	710	2600	4,5	13 x 500	6 x 500	2 x 500	500	1 x 300	300
	FSL 71.12 S	11300	83,6	36,93	17800	1	710	2600	4,5	18 x 500	9 x 500	2 x 500	500	1 x 300	300
	FSL 71.21 S	17200	111,4	49,24	38800	2	710	5200	9,0	14 x 1000	7 x 1000	2 x 1000	1000	2 x 300	300
	FSL 71.22 S	22800	167,2	73,87	35600	2	710	5200	9,0	19 x 1000	9 x 1000	2 x 1000	1000	2 x 300	300
	FSL 71.31 S	24500	167,2	73,87	58200	3	710	7800	13,5	13 x 1500	6 x 1500	2 x 1500	1500	3 x 300	300
	FSL 71.32 S	33300	250,8	110,80	53300	3	710	7800	13,5	18 x 1500	9 x 1500	2 x 1500	1500	3 x 300	300
	FSL 71.41 S	34500	222,9	98,50	77600	4	710	10400	18,0	12 x 2000	6 x 2000	2 x 2000	2000	4 x 300	300
	FSL 71.42 S	44600	334,3	147,70	71100	4	710	10400	18,0	18 x 2000	9 x 2000	2 x 2000	2000	4 x 300	300

- Kapasiteler R 404 A için -35 °C oda ve -40 °C evaporasyon şartlarında verilmifitir. Diğer kofullar için Kapasite Düzeltme Faktörü hesab-n kullan-n.
- Capacities at -35 °C room and -40 °C evaporation temperature conditions for R 404 A. For other conditions, please use Capacity Correction Factor calculation.
- Der Leistungsbereich liegt bei -35 °C raum und -40 °C Verdampfungstemperatur. Für unterschiedlich Bedingungen verwenden Sie bitte die angegebenen Korrektur faktoren.

K SERİSİ • K SERIES • K SERIE



T SERİSİ • T SERIES • T SERIE



fi OK DONDURUCU KAPASİTE TABLOSU • BLAST FREEZER CAPACITY TABLE • SCHOCKFROSTER LEISTUNGSTABELLE

Hatve Fin Spacing / Lamellenabstand	Model Model / Modell	Kapasite Capacity / Nenn-Leistung	Yüzey Surface / Oberfläche	Boru Hacmi Tube Volume / Rohrinhalt	Fanlar Fans / Ventilatoren					Defrost İş-t-c-leri Electric Defrost / Elektrische Abtaugung					
					Hava Debisi Air Flow / Luftmenge	Say-sı Number / Anzahl	Çap Diameter / Durchmesser	Güç Power / Leistung	Akım Current / Strom	Batarya Coil / Batterie	Yedek Spare / Vorrat	Drenaj Tavası Drain Pan / Tropfwanne	Yedek Spare / Vorrat	Fan Davlumbaz Yakası Fan Housing Collar Ventilatore	Drenaj Hattı Drain Line / Wasserablauf
mm		W	m <sup>2</sup>	dm <sup>3</sup>	m <sup>3</sup> /h	n	mm	W	A	W	W	W	W	W	W
12 mm	FSL 63.21 K	13400	90,0	39,77	33000	2	630	3800	6,4	14 x 650	7 x 650	2 x 650	650	2 x 300	300
	FSL 63.22 K	18500	135,0	59,67	32000	2	630	3800	6,4	20 x 650	10 x 650	2 x 650	650	2 x 300	300
	FSL 63.41 K	27500	180,0	79,56	66000	4	630	7600	12,8	14 x 1250	7 x 1250	2 x 1250	1250	4 x 300	300
	FSL 63.42 K	36500	270,0	118,41	64000	4	630	7600	12,8	20 x 1250	10 x 1250	2 x 1250	1250	4 x 300	300
	FSL 63.61 K	40900	270,0	119,36	99000	6	630	11400	19,2	14 x 2000	7 x 2000	2 x 2000	2000	6 x 300	300
	FSL 63.62 K	56700	405,0	179,04	96000	6	630	11400	19,2	20 x 2000	10 x 2000	2 x 2000	2000	6 x 300	300
	FSL 63.12 T	6200	41,9	18,94	16000	1	630	1900	3,2	9 x 500	3 x 500	3 x 500	-	1 x 300	300
	FSL 63.13 T	8600	62,8	28,41	15500	1	630	1900	3,2	12 x 500	6 x 500	3 x 500	-	1 x 300	300
	FSL 63.22 T	12600	83,7	37,88	32000	2	630	3800	6,4	9 x 1000	3 x 1000	3 x 1000	-	2 x 300	300
	FSL 63.23 T	17700	125,6	56,83	31000	2	630	3800	6,4	12 x 1000	6 x 1000	3 x 1000	-	2 x 300	300
	FSL 63.32 T	19100	125,6	56,83	48000	3	630	5700	9,6	9 x 1500	6 x 1500	3 x 1500	-	3 x 300	300
	FSL 63.33 T	26700	188,3	85,24	46500	3	630	5700	9,6	12 x 1500	6 x 1500	3 x 1500	-	3 x 300	300
	FSL 63.42 T	25400	167,4	73,87	64000	4	630	7600	12,8	9 x 2000	3 x 2000	3 x 2000	-	4 x 300	300
	FSL 63.43 T	35600	251,1	110,80	62000	4	630	7600	12,8	12 x 2000	3 x 2000	3 x 2000	-	4 x 300	300

- Kapasiteler R 404 A için -35 °C oda ve -40 °C evaporasyon şartlarında verilmifitir. Diğer kofullar için Kapasite Düzeltme Faktörü hesab-n kullan-n.
- Capacities at -35 °C room and -40 °C evaporation temperature conditions for R 404 A. For other conditions, please use Capacity Correction Factor calculation.
- Der Leistungsbereich liegt bei -35 °C raum und -40 °C Verdampfungstemperatur. Für unterschiedlich Bedingungen verwenden Sie bitte die angegebenen Korrektur faktoren.

BOYUTLAR • DIMENSIONS • ABMESSUNGEN

S ve H SERİSİ fi OK DONDURUCU BOYUT TABLOSU  
S and H SERIES BLAST FREEZER DIMENSION TABLE • S und H SERIE SHOCKFROSTER MAßE

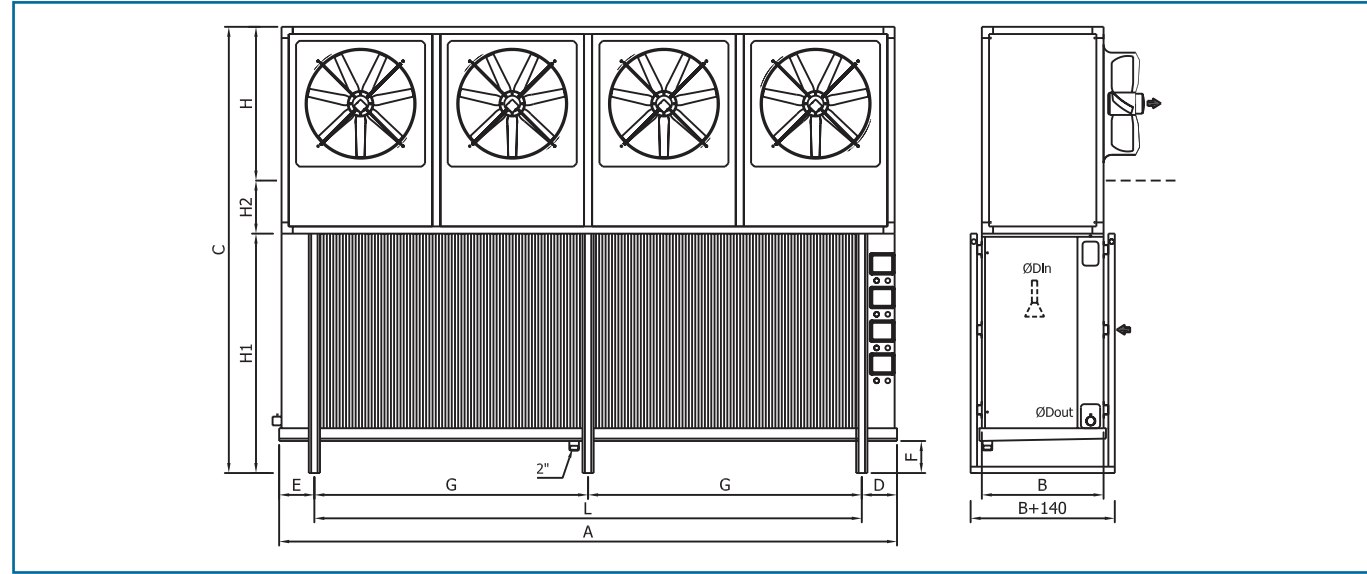

Model • Model • Modell	L	A	B	C	D	E	F	G	H	H1*	H2*	D <sub>in</sub>	D <sub>out</sub>	Kg
FSL 63.11 S	870	1310	675	2390	220	220	200	-	895	1495	0	22	35	260
FSL 63.12 S	870	1310	835	2390	220	220	200	-	895	1495	0	22	35	290
FSL 63.21 S	1670	2110	675	2390	220	220	200	-	895	1495	0	22	42	410
FSL 63.22 S	1670	2110	835	2390	220	220	200	-	895	1495	0	22	54	470
FSL 63.31 S	2470	2910	675	2390	220	220	200	-	895	1495	0	22	54	550
FSL 63.32 S	2470	2910	835	2390	220	220	200	-	895	1495	0	22	54	645
FSL 63.41 S	3270	3710	675	2390	220	220	200	1635	895	1495	0	22	54	700
FSL 63.42 S	3270	3710	835	2390	220	220	200	1635	895	1495	0	35	66	820
FSL 71.11 S	1070	1510	675	2750	220	220	200	-	950	1800	0	22	35	300
FSL 71.12 S	1070	1510	835	2750	220	220	200	-	950	1800	0	22	42	345
FSL 71.21 S	2070	2510	675	2750	220	220	200	-	950	1800	0	22	54	485
FSL 71.22 S	2070	2510	835	2750	220	220	200	-	950	1800	0	22	54	560
FSL 71.31 S	3070	3510	675	2750	220	220	200	-	950	1800	0	22	54	670
FSL 71.32 S	3070	3510	835	2750	220	220	200	-	950	1800	0	35	66	780
FSL 71.41 S	4070	4510	675	2750	220	220	200	2035	950	1800	0	35	66	850
FSL 71.42 S	4070	4510	835	2750	220	220	200	2035	950	1800	0	35	80	1000
FSL 63.11 H	870	1310	675	2750	220	220	200	-	895	1495	360	22	35	275
FSL 63.12 H	870	1310	835	2750	220	220	200	-	895	1495	360	22	35	315
FSL 63.21 H	1670	2110	675	2750	220	220	200	-	895	1495	360	22	42	450
FSL 63.22 H	1670	2110	835	2750	220	220	200	-	895	1495	360	22	54	500
FSL 63.31 H	2470	2910	675	2750	220	220	200	-	895	1495	360	22	54	600
FSL 63.32 H	2470	2910	835	2750	220	220	200	-	895	1495	360	22	54	685
FSL 63.41 H	3270	3710	675	2750	220	220	200	1635	895	1495	360	22	54	750
FSL 63.42 H	3270	3710	835	2750	220	220	200	1635	895	1495	360	35	66	870

\*H1 + H2 ürün yüklemeye yüksekliği olup, standart montaj ayakları farklı seviyede montaj edilmesi suretiyle artırılabilir.  
\*H1 + H2 dimension is height of product loading carriage and can be higher by mounting standard supporting legs at different levels.  
\*H1 + H2 ist die Ladungshöhe, die durch unterschiedliche Montagehöhen der genormten Montagestützen verändert werden kann.

BOYUTLAR • DIMENSIONS • ABMESSUNGEN

K SERİSİ fi OK DONDURUCU BOYUT TABLOSU  
K SERIES BLAST FREEZER DIMENSION TABLE • K SERIE SHOCKFROSTER MAßE

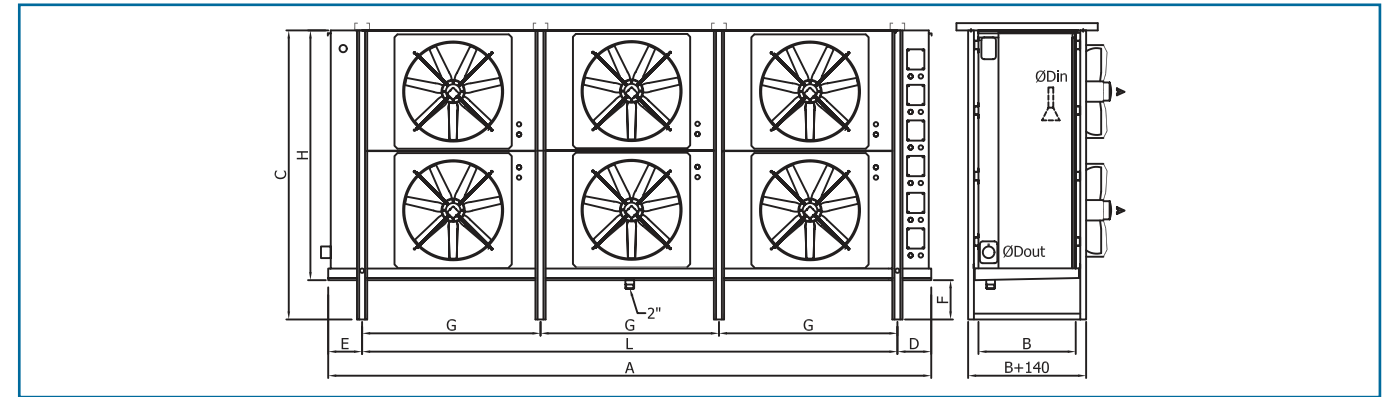

Model • Model • Modell	L	A	B	C	D	E	F	G	H*	D <sub>in</sub>	D <sub>out</sub>	Kg
FSL 63.21 K	1250	1715	670	1985	232,5	232,5	270	-	1715	22	42	370
FSL 63.22 K	1250	1715	830	1985	232,5	232,5	270	-	1715	22	54	450
FSL 63.41 K	2450	2915	670	1985	232,5	232,5	270	1225	1715	22	54	630
FSL 63.42 K	2450	2915	830	1985	232,5	232,5	270	1225	1715	35	66	770
FSL 63.61 K	3650	4115	670	1985	232,5	232,5	270	1215	1715	2 X 22	2 X 54	900
FSL 63.62 K	3650	4115	830	1985	232,5	232,5	270	1215	1715	2 X 22	2 X 66	1100

\*Standart montaj ayakları farklı seviyede montaj edilmesi suretiyle, ürün yüklemeye yüksekliği artırılabilir.  
\*By mounting standard supporting legs at different levels, the height of product loading carriage can be higher.  
\*Durch höhenverstellbare Standardmontagefüße kann die Transporthöhe verändert werden.

T SERİSİ fi OK DONDURUCU BOYUT TABLOSU  
T SERIES BLAST FREEZER DIMENSION TABLE • T SERIE SHOCKFROSTER MAßE

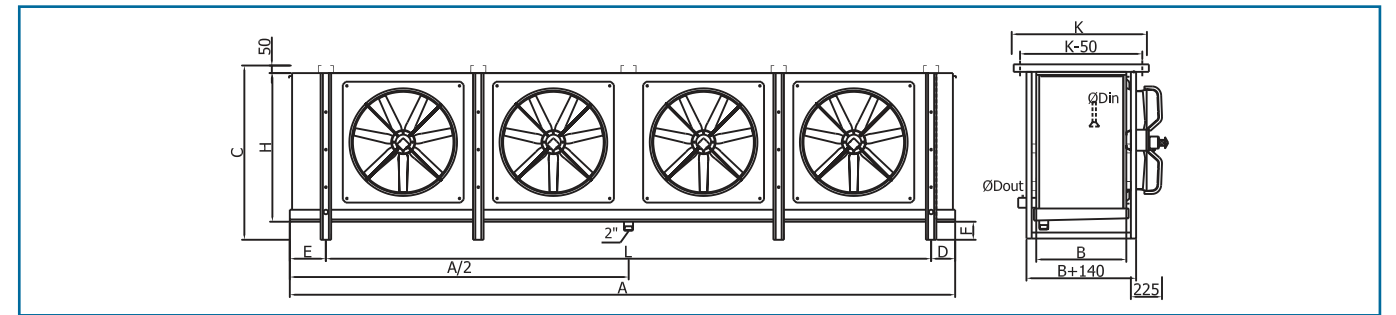

Model • Model • Modell	L	A	B	C	D	E	F	K	H	D <sub>in</sub>	D <sub>out</sub>	Kg
FSL 63.12 T	1050	1450	630	1160	240	160	120	900	990	5/8"	28	185
FSL 63.13 T	1050	1450	730	1160	240	160	120	1000	990	19	35	215
FSL 63.22 T	2050	2450	630	1160	240	160	120	900	990	22	42	320
FSL 63.23 T	2050	2450	730	1160	240	160	120	1000	990	22	42	380
FSL 63.32 T	3050	3450	630	1160	240	160	120	900	990	22	54	445
FSL 63.33 T	3050	3450	730	1160	240	160	120	1000	990	22	54	530
FSL 63.42 T	4050	4450	630	1160	240	160	120	900	990	22	54	590
FSL 63.43 T	4050	4450	730	1160	240	160	120	1000	990	35	66	710