

CARBON DIOXIDE-DETECTOR I2649CO2 FOR EX-ZONE 2

Designed to meet with light industrial requirements, the I2649CO₂ gas detectors allows monitoring flammable contents in areas classified as zone 2, category 3.

Ideal in light industrial environments the gas detector feature one man calibration via calibration keypad.

The detectors is IP65 protected and SIL2 Hardware tested (not certified) and provides a simple concept to replace sensors.

As an option the gas detectors is also available with a display.



SPECIFICATIONS ELECTRONICS

SUPPLY: 24 VDC | **POWER CONSUMPTION:** max. 130 mA | **WIRING ANALOGUE/DIGITAL:** 3×0,75 mm² up to 100 m, shielded, 2×2×0,75 mm², shielded | **SIGNAL-OUTPUT ANALOGUE/DIGITAL:** 4...20 mA, Modbus RTU | **OPTIONAL RELAY OUTPUTS:** 1 or 3 | **WEIGHT:** 850...1200 gr | **ATEX CERTIFIED FOR:** II 3G

SPECIFICATIONS SENSOR

MEASURING PRINCIPLE: Infrared | **MEASURING RANGE:** 0...2 Vol. % (Type I2650CO₂ 0...5 Vol. % / Type I2443CO₂ 0...30 Vol. % /) | **ACCURACY:** +/- 2 % of measuring range | **RESPONSE TIME:** t₉₀: < 30 sec | **OPERATION TEMPERATURE:** -40 °C ...+60 °C | **HUMIDITY:** 20...90 % (non condensing) | **APPROX. LIFETIME AT 20°C:** > 8 years, depending on application | **CALIBRATION:** It is necessary to inspect the gas detector every 6 month and to recalibrate it only if needed.

DIMENSIONS AND CONNECTIONS

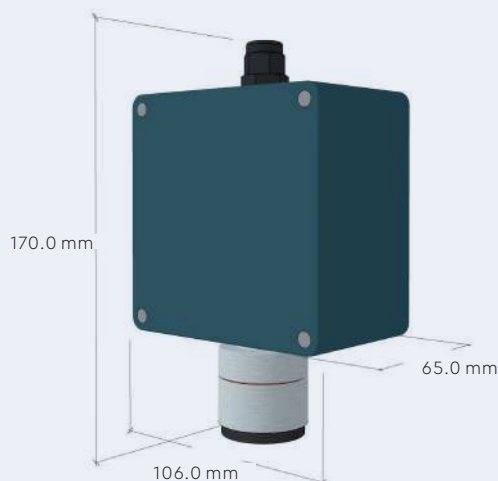

24VDC Bus1	○	BUS A	○	BUS B	○	0VDC	○	+ Analog	○	S Analog	○
Ex-Gas Detector											