



Cetecoil / Cetetube

User manual



Table of contents

| | |
|---|---|
| General remarks..... | 3 |
| Usage..... | 3 |
| Improper use..... | 4 |
| Installation and connection..... | 4 |
| Siting..... | 4 |
| Support / foundation / load capacity..... | 4 |
| Adjustment..... | 4 |
| Connection..... | 4 |
| Operating data / temperature..... | 6 |
| Assembly..... | 6 |
| Piping connection..... | 6 |
| Equipotentiality..... | 6 |
| Operation..... | 7 |
| Controls..... | 8 |
| Maintenance..... | 8 |
| Disabling / Out of service / Dismantling..... | 8 |
| Safety related technical information..... | 9 |

General information

Copyrights remain property of Alfa Laval. Information, pictures and drawings of this user manual may not be reproduced, disclosed or used for advertising purposes, or transmitted to third parties without prior authorisation.

Alfa Laval reserves the right to bring any modifications necessary to the improvement of heat exchangers.

This manual contains important information regarding correct operation and security for this equipment. This manual must be made available at all times to assembly technicians and operators. Make sure this manual is always at hand for your personnel.

Make sure you include the manual in the event of a sale or transfer of property of this equipment. Please notify us immediately of the name and address of the new owner in the unexpected case we need to communicate information relative to the security of this equipment.

Please read this manual thoroughly before installing the device. Please take note of safety information.

Usage

Heat exchangers must only be used in accordance with recommendations. Please respect the load limit for this equipment. Alfa Laval declines any responsibility in case of unconventional use.

Cetecoil and Cetetube. L-M-H series shell and tube heat exchangers are suitable for installation of urban heating systems, drinking water heating, heat recovery installations, systems separation and industrial process techniques. Cetecoil can also be used as a condenser for saturated water steam.

Applications for heat exchangers are based on individual components. See list in charts 1 and 2:

Chart 1: Field of application for Cetecoil

| Type | Tube side connection | Shell side connection |
|------|---|--|
| S | District heating Steam | Heating District heating |
| R | Drinking water District heating Steam | Heating Heating District heating |
| E | Drinking water District heating Steam | Drinking water Drinking water Drinking water |
| D | District heating Steam | Heating District heating |

Chart 2: Field of application for Cetetube

| Type | Tube side connection | Shell side connection |
|------|------------------------------------|-----------------------|
| - | Drinking water District heating | Heating Heating |

Improper use

Any use outside the field of application is considered improper. The manufacturer cannot be held responsible for applications outside this field of application.

Installation and connection

Connection and management of the shell and tube heat exchanger must be done in accordance with standard technical rules. The user is required to perform all tasks or have all tasks performed in an appropriate manner. Every heat exchanger is equipped with a manufacturer label mentioning regulatory information. The information on the manufacturer's name plate refers to European guidelines 97/23 EG relative to compressors, which this product complies to.

Remark: Please ensure that the device has not been damaged during transport and that all parts mentioned in the packing list are present.

Caution: Installation and commissioning of the device must be performed by a specialised company, able to take responsibility of the compliance of the assembly, connection and equipment.

Heat exchangers are very heavy with a high centre of gravity. Please be very careful when transporting such equipment and use only appropriate equipment such as forklifts, cranes or pallet loaders.

Siting

Installation of the device must be made in a room protected from frost, flooding and correctly ventilated. The maximal ambient temperature of the room where the device is installed must not exceed 40°C. A minimum distance of 60 cm between the wall and the device should be observed, to allow for maintenance and control.

Support / foundation / load capacity

The load capacity of the support must equal the weight of the device (see delivery documents).

Adjustment

The heat exchanger must be placed in its destined place and installed horizontally. On a soft support, it is required to place shims/chock blocks under the legs of the device to prevent it from sinking into the support.

Connection

The piping used to connect the heat exchanger must be resistant to chemical reactions, mechanical stress and other constraints related to the expected pressure and temperature. No reaction torque or vibration must be conducted through the piping connected to the device.

The heat exchanger was designed based on **the counterflow principle**. In order to fully benefit from the total production capacity of the heat exchanger, the principle must be observed when connecting the piping to the heat exchanger.

The piping connection principle is based on the fact that it is the warmer fluids (e.g. the fluid with the highest temperature difference) that are meant to flow in the pipes. Exception:

R-type heat exchangers and Cetetube used for heating drinking water. Since drinking water can only be in contact with steel components or copper pipe circuits of the heat exchanger (with exception to Cetecoil E), drinking water pipes must always be connected to water piping connectors.

A/B connectors are admission or outlet pipes designed for C/D piping and connectors of the casing.

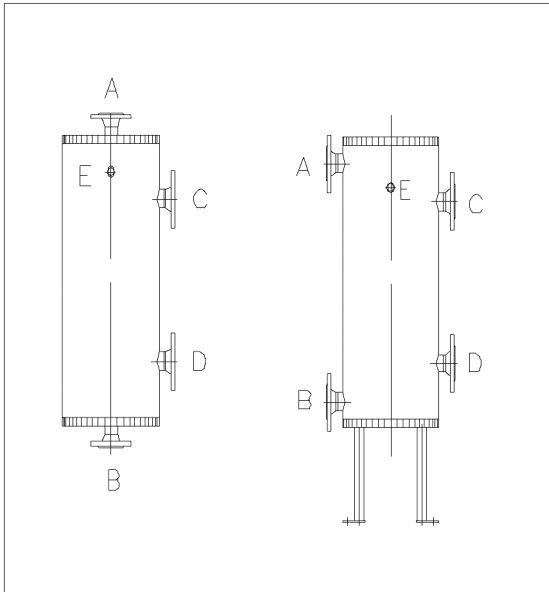

The **primary connection** must be performed by specialised personnel or with the permission of the company in charge of district heating.

Where district heating is used as the energy source, the company in charge of district heating performs the primary side phasing in and then the control report.

Flux and reflux must be connected to the corresponding positions. The accumulated primary water must conform with the instructions of spec sheet Tch 1466 of VdTÜV/AGFW.

Installation of a particulate filter to prevent fouling of the heat exchanger is recommended to ensure perfect operation.

The **secondary connection** must be performed by specialised personnel. During the heating of the drinking water, DIN 1988 and DIN 4753 standards must be observed as well as the local regulations of the company in charge of district heating.

Stored drinking water must respect the local rules and conform to regulations on drinking water.

We recommend fitting a filter on the cold water pipe in order to remove solid particles that could be present in the water distribution system. Without a filter, there is an acute risk of pollution and corrosion of the device.

Operating data / temperature

Tube bundle

| Cetecoil type | S | | R | | E | | D | |
|--|-----|-----|-----|-----|-----|-----|-----|-----|
| Max operating service temperature (°C) | 200 | 300 | 200 | 300 | 200 | 300 | 200 | 300 |
| Max operating service pressure (bar) | 25 | 19 | 16 | 14 | 16 | 14 | 25 | 22 |

| Cetecoil type | S | | R | | E | | D | |
|--|-----|-----|-----|-----|-----|-----|-----|-----|
| Max operating service temperature (°C) | 200 | 300 | 200 | 300 | 200 | 300 | 200 | 300 |
| Max operating service pressure (bar) | 16 | 12 | 16 | 14 | 16 | 14 | 25 | 19 |

| Cetetube service data | Piping | Tank |
|--------------------------------------|--------|------|
| Max operating service pressure (bar) | 160 | 150 |
| Max operating service pressure (bar) | 25 | 16 |

A special attention should be paid to the compatibility of the distribution system with the material delivered with the heat exchanger (among others things, the flow rule as per DIN 1988 standard part 7 paragraph 3.3.2).

Assembly

Hereinafter, a description of basic information related to assembly and commissioning. Keeping in mind further inspections, ensure ulterior dismantling and re-assembly of thermal insulation are possible. Ensure that the information on the manufacturer's name plate corresponds to the operating conditions.

Subsequent welding on heat exchangers is not permitted!

Piping connection

The installation must be exempt of stress in the piping network (eventual use of compensators).

Equipotentiality

Equipotentiality is a passive preventive measure; it is supposed to compensate or re-route any leakage current due to potential differences in the plant.

For any installation composed of a heat exchanger and related piping system, an equipotential bonding must always be installed and connected to the equipotential bonding rail present in the building.

The potential compensation system connectors must have a minimal diameter of 0.5 * PE (6 mm is recommended)

For a fully functional equipotentiality, the bonding should be done on the whole length of all elements integrated to the piping (flange joints as well as non-conducting plastic elements, for example).

Operation

Commissioning

The installation will be commissioned by an expert or a specialist. The heat exchanger must be controlled at the dates specified by the expert specialists (for compressor compliance, for example).

Preliminary conditions

An installation can only be commissioned after its assembly, installation, operation and security settings have been controlled by an appropriate person or certified company.

The commissioning of the heat exchanger must be follow a specific order. This specific order is described step-by-step in the following:

Commissioning procedure

During the first fluid filling of the installation, ensure that all connectors are suitably tightened, and if required tighten with an appropriate tool. Also make sure they are all correctly in place to ensure their water-tightness. When preliminary conditions are respected, commissioning can start:

1. Fill the heat exchanger on the tube side and the shell side.
2. Make sure the built-in safety elements are operational
3. The heat exchanger monitoring can then start. To do so, the circuit with the lowest temperature must be activated first, then the circuit with the highest temperature is activated.
4. Pumps must be started with all valves shut to avoid pressure bursts.
5. Slowly open both inlet and outlet valves simultaneously. Flow rates must be slowly increased until operating temperature is reached.
6. Commissioning is to be performed by expert protocol, and documented.
7. After the first commissioning and after the operating temperature is reached, all connectors must be controlled to ensure they are in place and tightened when the device is cooled down and without pressure. Tighten again if needed.
8. Repeat steps 1 to 7

By safety measure, the user will be instructed and familiarised with the device's features by the company who installed it.

Secondary side: Flushing and filling of the secondary side is performed by the qualified personnel of the company installing the device.

- Make sure no fouling enters the system by controlling air intake.
- The filling pressure must not exceed the inlet pressure set at the safety valve level.
- Information relative to the filling pressure can be found on the safety valve.
- If the filling pressure is exceeded, the room might get flooded.

Primary side: The flushing of the primary connection must be performed by specialised personnel or with the permission of the company in charge of district heating.

- Information given in the "Secondary side" chapter also applies to this side.
- Keep in mind that leaks on the primary side may result in severe burns caused by hot water.

Controls

General information

The heat exchanger works autonomously after flushing, filling and setting of the flow rate and temperature. This operating manual should allow the qualified personnel of the specialised company to adjust the settings.

Any defect must be reported in writing!

Maintenance

Heat exchangers can be drained via the purpose-built connectors. Draining and opening, as well as flushing of the heat exchanger can only be performed after the fluids have cooled down. The devices must be in no-pressure status.

Water-tightness of all connectors, flange joints and water-tightness functions must be checked regularly. With time, the elasticity of water-tightening materials deteriorates due to the constant operation temperature changes. Flange joints are also affected and leaks may happen.

We therefore recommend that regular visual and tactile checks are performed on all connectors.

Disabling / Out of service / Dismantling

The run-down of the heat exchanger and shut-down of both fluids must be done simultaneously. If this is not possible, the hot side must be stopped first.

In case of frost risk or presence of aggressive fluids, the device must be totally drained and cleaned. The drain cock must remain open while the device is stopped.

Out of service – Caution, burn risk!

In the event of a leak on the primary side, water or steam may leak at temperatures higher than 100°C. Caution: once the device is stopped, it remains hot for some time and the burn risk is still present.

Dismantling

To dismantle the device, follow this procedure:

1. Place the primary side in Out of service state, if necessary with the agreement of the company in charge of district heating.
2. Lock the secondary side.
3. Let the device cool down before dismantling.
4. Drain the device.
5. Dismantle the device.

Shall the heat exchanger be disposed of, ensure this is done according to the regulations. If such an agreement exists, recyclable parts must be returned to the manufacturer.

Safety related technical information

Prescriptions and standards

- The installation must be connected with respect to the local laws and standards (EN, DIN, VDE, etc...) or regulations of the local district heating company or water supply company.
- Company safety standards must also be adhered to, as well as TRD 721 standards.
- Safety features must respect EN/DIN standards.
- Safety valves and overflow pipes must be installed in an adequate manner so that they may not cause bodily harm in the event of a leak of steam or water.

Occupational safety

This heat exchanger was built using modern technology and its operation is safe. Such devices may nevertheless present a risk if they are not used or maintained by qualified personnel or if they are used in an improper manner.

Any person in charge of operating or maintaining the device must have read and understood the safety information.

The heat exchanger, and particularly the technical safety equipment can only be operated or maintained by qualified personnel. If you have any doubt, please contact your supervisor or the supplier or the manufacturer for further information.

Rules and procedures must be respected at all times. Do not operate the device in a way that compromises its safety.

As a rule, faulty safety equipment shall not be dismantled or reset without prior knowledge of DIN standards or without the assistance of an expert. Safety equipment protects from severe bodily harm (burns, electric shock, etc.). Any work on thermostats must be performed by an expert.

If any identifiable damage appears, especially on safety equipment, or if unusual noises and smells appear, unplug the device and contact your supplier immediately.

Any maintenance or cleaning task performed on the heat exchanger must be done with the device turned off.

The device must be protected from unauthorised operation.

Note on potential risks

If there is a leak on the primary side, steam will leak when the temperature is above 100°C. Any contact with hot water steam can cause severe burns. Avoid any contact with steam. Caution: Once the device is stopped, it remains hot for some time and the burn risk is still present.

All piping parts of the installation are hot during operation. Any contact with the piping of the installation can cause severe burns. Avoid contact with any hot part of the installation.

Warning relative to modifications and transformations initiated by the end-user

For safety reasons, modifications and transformations initiated by the end-user are not authorised and will result in loss of warranty.

Re-commissioning after out of service state

Recommissioning after out of service state must be performed by specialised personnel or with the permission of the company in charge of district heating. Please refer to chapter "Commissioning".

Recommissioning after prolonged inactivity of the device

Recommissioning after prolonged out of service state must be performed by specialised personnel or with the permission of the company in charge of district heating.

Check the fouling collectors and clean them if necessary. Recommissioning can then be initiated, please refer to chapter "Commissioning"

Alfa Laval in brief

Alfa Laval is a leading global provider of specialized products and engineered solutions.

Our equipment, systems and services are dedicated to helping customers to optimize the performance of their processes. Time and time again.

We help our customers to heat, cool, separate and transport products such as oil, water, chemicals, beverages, foodstuffs, starch and pharmaceuticals.

Our worldwide organization works closely with customers in almost 100 countries to help them stay ahead.

How to contact Alfa Laval

Up-to-date Alfa Laval contact details for all countries are always available on our website at www.alfalaval.com

Alfa Laval reserves the right to change specifications without prior notification.

August 2008