

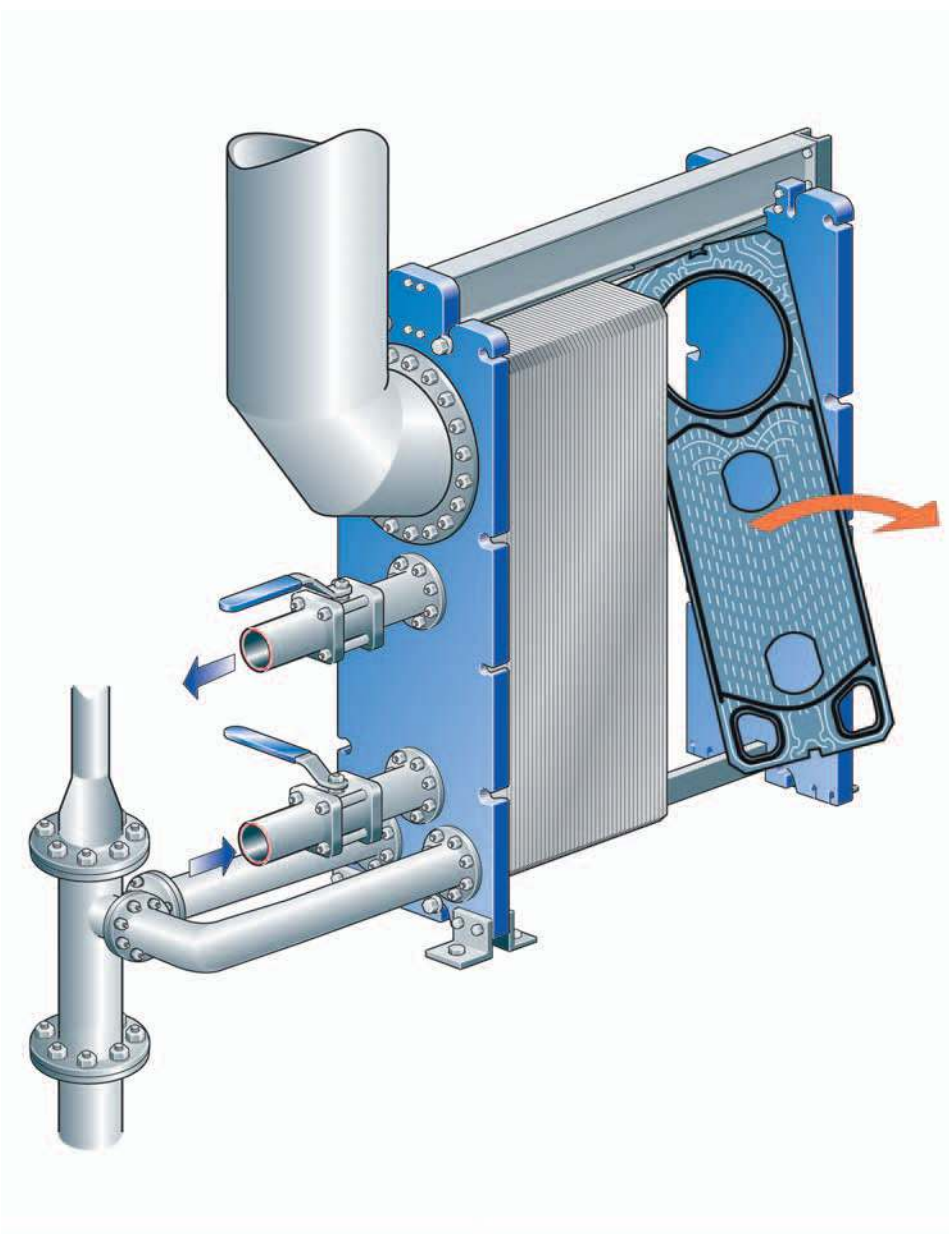

EN

## Instruction Manual Plate Condenser

# AlfaCond 400/600/800







## Table of contents

EN

<b>Description</b> .....	1
Main components .....	1
Function .....	2
<b>Installation</b> .....	3
Requirements .....	3
Lifting .....	4
<b>Operation</b> .....	5
Start-up .....	5
Unit in operation.....	6
Shut-down.....	6
<b>Maintenance</b> .....	7
Cleaning-In-Place (CIP).....	7
Manual cleaning.....	8
Regasketing.....	15

### How to contact Alfa Laval:

Contact details for all countries are continually updated on our website.

Please visit [www.alfalaval.com](http://www.alfalaval.com) and contact your local Alfa Laval Representative.

Except for this Instruction Manual, the following documents are also included in this shipment:

- AlfaCond drawing
- Plate hanging list
- Parts list with exploded view drawing.



## Environmental compliance

**AlfaLaval endeavours to perform its own operations as cleanly and efficiently as possible, and to take environmental aspects into consideration when developing, designing, manufacturing, servicing and marketing its products.**

### Unpacking

Packing material consists of wood, plastics, cardboard boxes and in some cases metal straps.

- Wood and cardboard boxes can be reused, recycled or used for energy recovery.
- Plastics should be recycled or burnt at a licensed waste incineration plant.
- Metal straps should be sent for material recycling.

### Maintenance

During maintenance oil and wear parts in the machine are replaced.

- All metal parts should be sent for material recycling.
- Worn out or defective electronic parts should be sent to a licensed handler for material recycling.
- Oil and all non metal wear parts must be taken care of in agreement with local regulations.

### Scrapping

At end of use, the equipment shall be recycled according to relevant, local regulations. Beside the equipment itself, any hazardous residues from the process liquid must be considered and dealt with in a proper manner. When in doubt, or in absence of local regulations, please contact the local AlfaLaval sales company.

## Description

### Main components

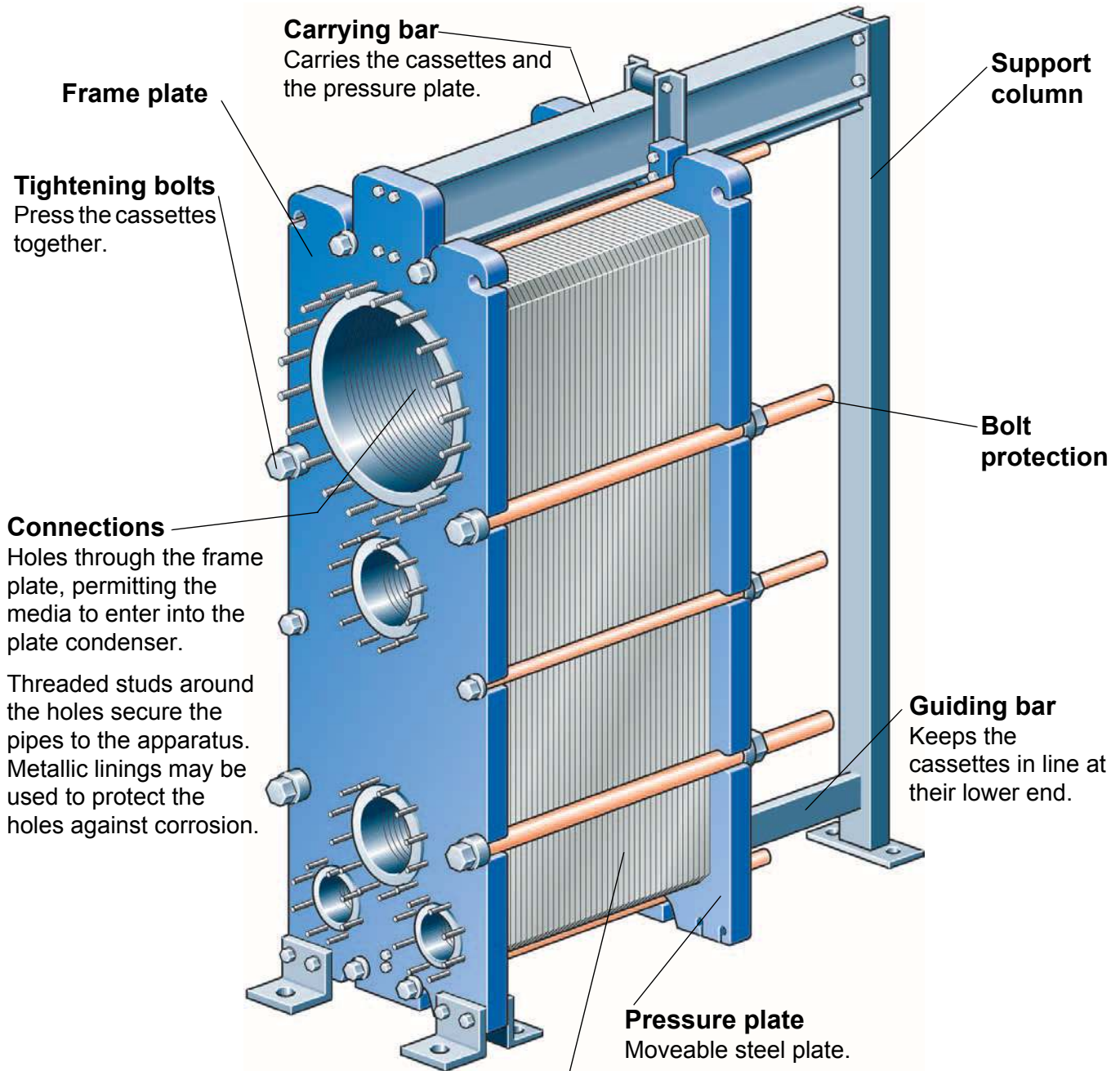

**Cassettes**  
Heat is transferred from one medium to the other through the thin plates.  
The number of cassettes determines the total heat transfer surface.

**Protective sheets**  
Supplied on request.

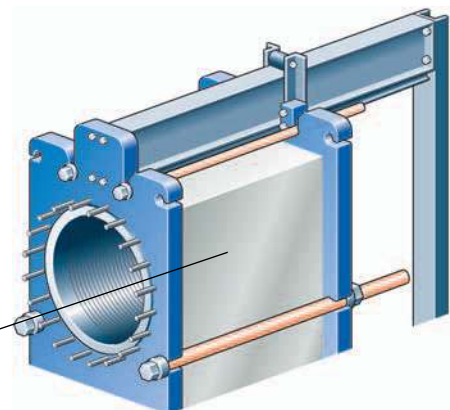



## Function

AlfaCond consists of a plate pack with plates welded together in pairs forming so-called cassettes.

The cassette concept gives rise to two different type of channels – welded channels used for the condensing vapour and gasketed channels used for the cooling water.

The plate pack is assembled between a frame plate and a pressure plate and compressed by tightening bolts.

The plate pattern is specifically designed for optimal condensation, with an asymmetric configuration that features a large gap on the vapour side and a small gap on the cooling water side. This makes it possible to maintain a very low pressure drop on the velocity and turbulence on the water side. This maximizes the heat transfer efficiency and minimizes fouling.

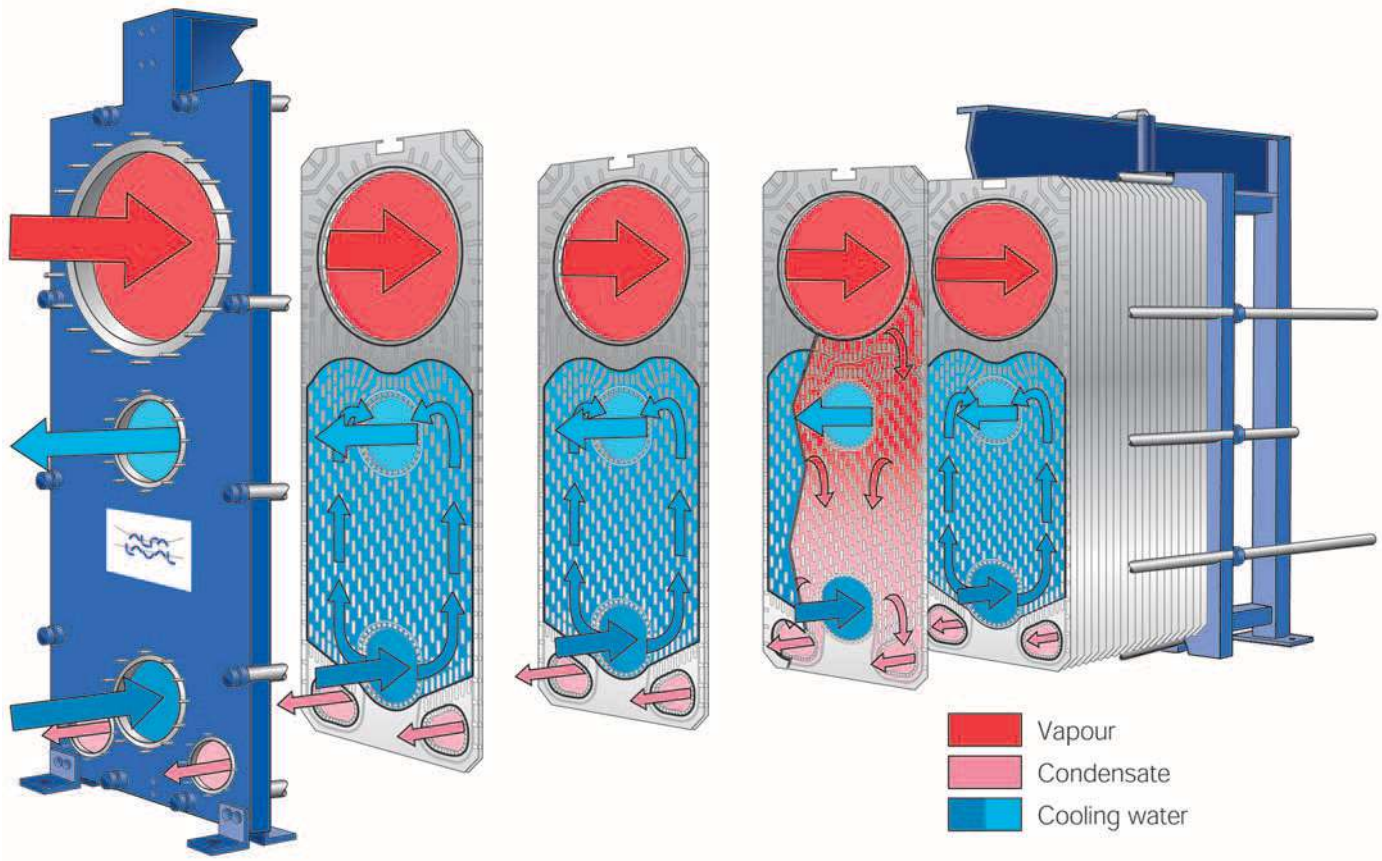



# Installation

## Requirements

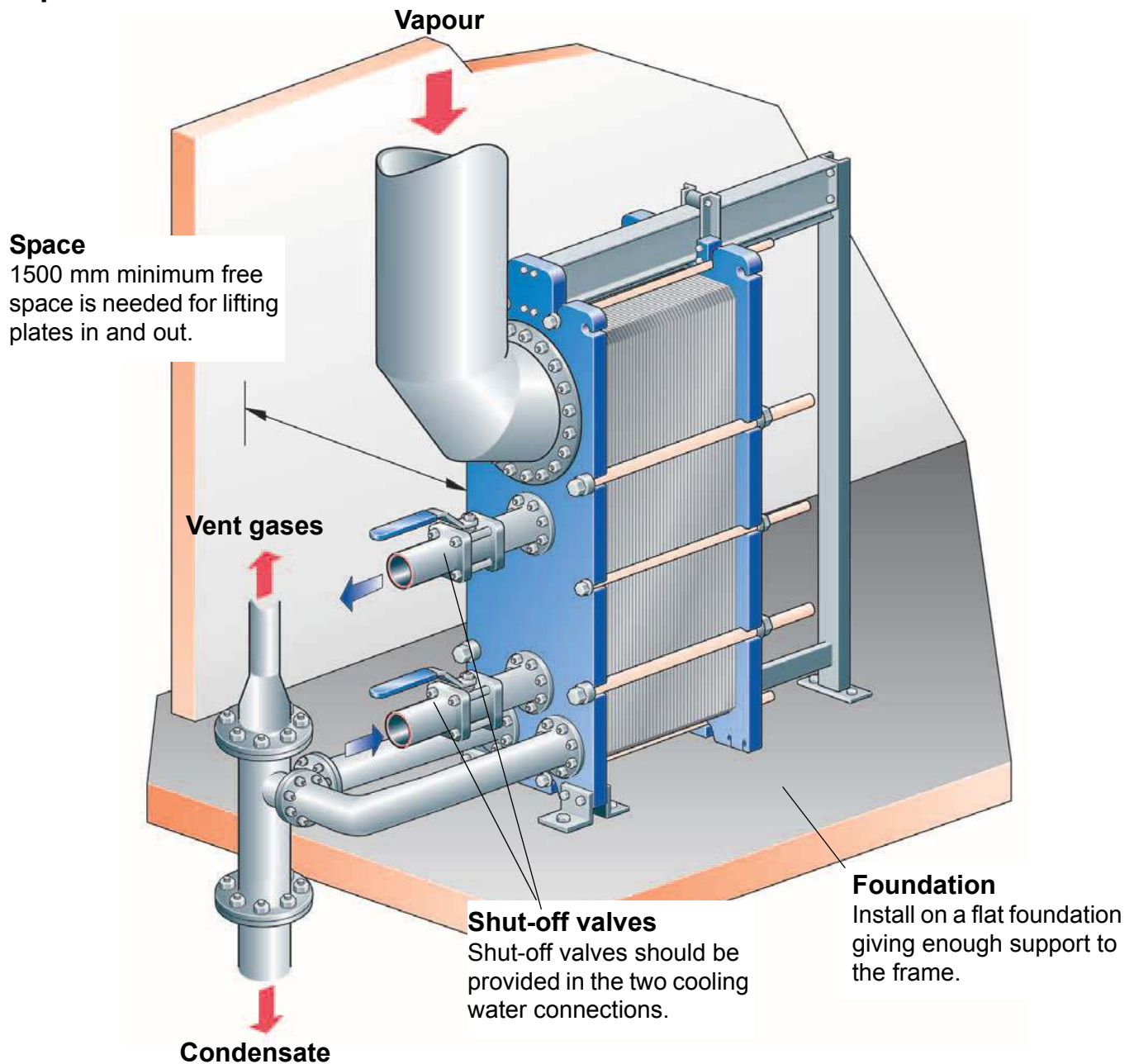

### Note!

- Before connecting any piping, make sure all foreign objects have been rinsed out of the system.
- When connecting the pipe system make sure the pipes do not subject the plate condenser to stress or strain.
- To avoid water hammer, do not use fast-closing valves.
- Before start-up, check that all tightening bolts are tightened and that measurement A is correct. For A, see enclosed plate condenser drawing.

Safety valves should be installed according to current pressure vessel regulations.

If the plate condenser surface temperature is expected to be hot or cold, the condenser should be insulated.

It is recommended that protective sheets are used to cover the plate condenser.

For each model, design pressures and temperatures are marked on the identification plate. Those must not be exceeded.

## Lifting



### Warning!

Never lift by the connections or the studs around them. Straps should be used when lifting. Place straps according to picture.

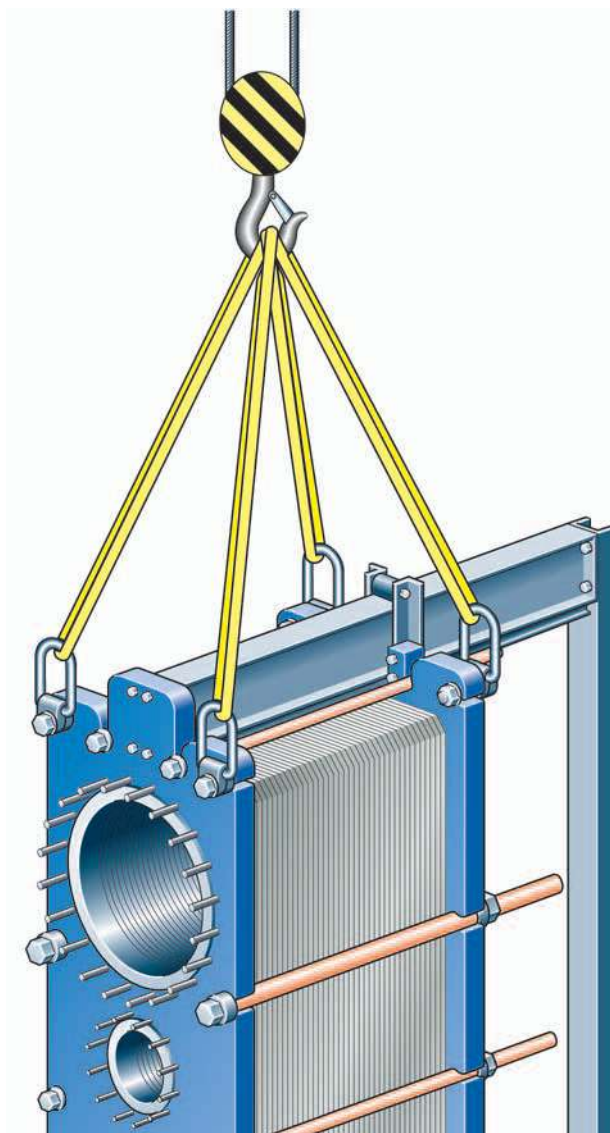



# Operation

## Start-up

### Note!

Adjustments of cooling water flow rate should be made slowly in order to avoid the risk of **water hammer**.

Water hammer is a shortlasting pressure peak that can appear during start-up or shut-down of a system, causing liquids to travel along a pipe as a wave at the speed of sound. This can cause considerable damage to the equipment.

- 1 Before start-up, check that that all tightened bolts are tightened and that measurement A is correct. For A, see enclosed plate condenser drawing.

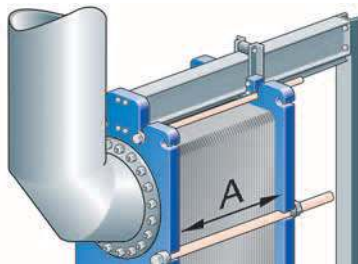

- 2 Check that the valve is closed between the pump and the cooling water inlet

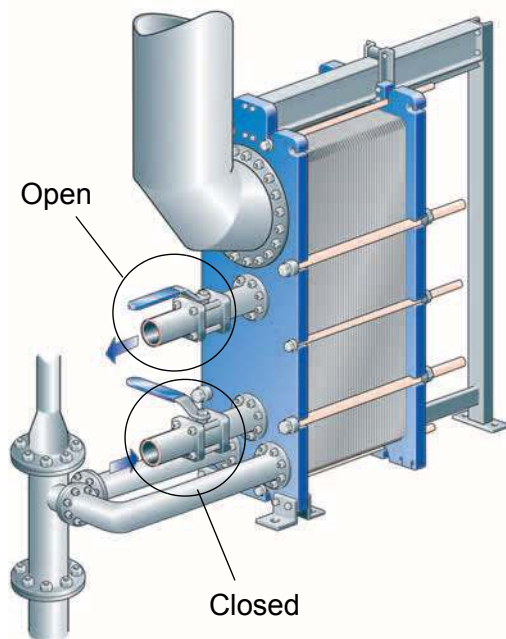

- 3 If there is a valve at the exit, make sure it is fully open.
- 4 Start the cooling water pump.
- 5 Open the valve slowly.

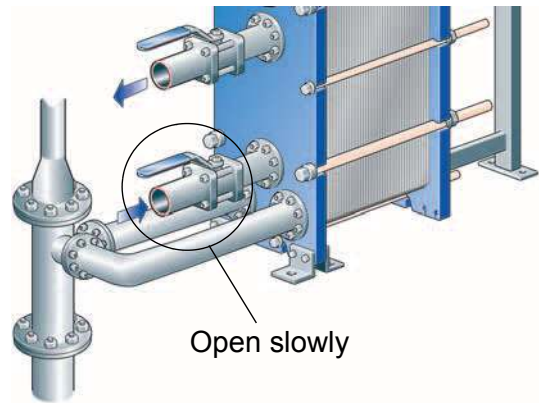

- 6 Start the vacuum system.
- 7 If there is a valve in the condensate outlet, make sure it is fully open.
- 8 Open the vapour supply.
- 9 When the plate condenser is evacuated from inert gases (pressure is down to operating pressure).

Adjust the vacuum system to an appropriate position.

## Unit in operation

### Note!

Adjustments of flow rates should be made slowly in order to protect the system against sudden and extreme variations of temperature and pressure.

During operation, check that

- media temperatures and pressures are within the limits stated on the plate condenser drawing
- no leakages appear due to faulty tightening of the plate pack or to defective or damaged gaskets
- carrying bar and guiding bar are kept clean and greased
- the bolts are kept clean and greased.

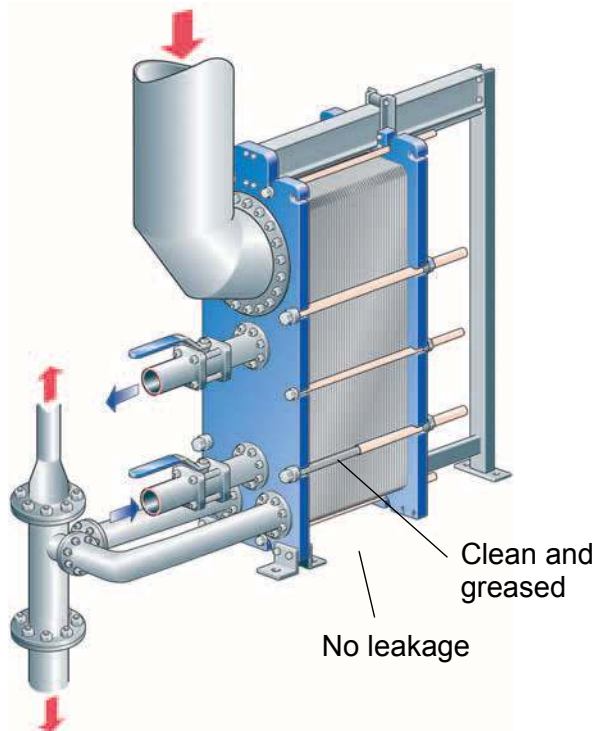

Always consult your local Alfa Laval office for advice on

- new plate pack dimensions if you intend to change number of plates
- selection of gasket material if operating temperatures and pressures are permanently changed, or if another medium is to be processed in the plate condenser.

## Shut-down

- 1 Close the vapour supply.
- 2 Close the vacuum system.
- 3 Slowly close the valve between the pump and the cooling water inlet.

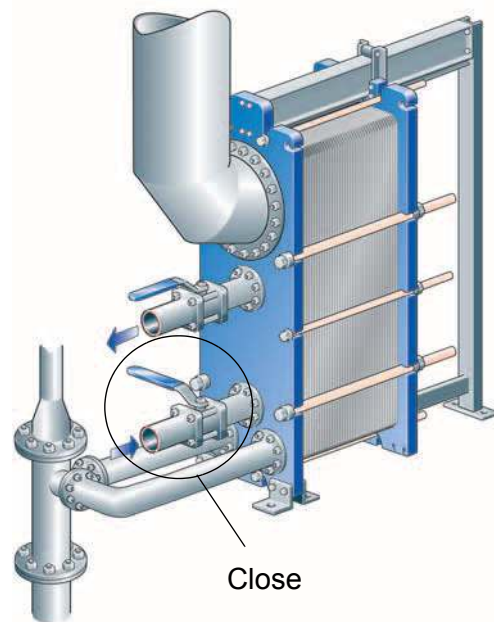

- 4 When the valve is closed, stop the pump.
- 5 Adjust the pressure to atmospheric pressure (only when opening the plate condenser).
- 6 If the plate condenser is shut down for several days or longer, it should be drained. Draining should also be done if the process is shut down and the ambient temperature is below freezing temperature of the media.

## Maintenance

### Cleaning-In-Place (CIP)

The Cleaning-In-Place (CIP) equipment permits cleaning of the plate condenser without opening it.

The following Alfa Laval-CIP models can be used: CIP75, CIP200, CIP400 and CIP800.

If CIP cannot be done, cleaning must be performed manually, see section “Manual cleaning”.

CIP performs

- cleaning of fouling and descaling of lime deposits
- passivation of cleaned surfaces to reduce susceptibility to corrosion
- neutralization of cleaning liquids before draining.

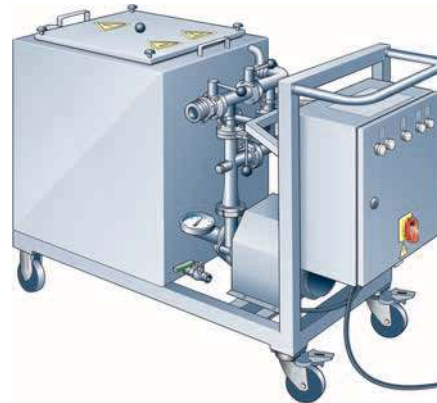

Follow the instructions of the CIP equipment.

#### Cleaning liquids

Cleaning liquid	Description
AlfaCaus	A strong alkaline liquid, for removing paint, fat, oil and biological deposits.
AlfaPhos	An acid cleaning liquid for removing metallic oxides, rust, lime and other inorganic scale.
AlfaPass	An alkaline liquid for passivation (inhibition of corrosion).
AlfaNeutra	A strong alkaline liquid for neutralization of AlfaPhos before drainage.
Alfa P-Scale	An acidic cleaning powder with a corrosion inhibitor particularly effective for removing of calcium carbonate and other inorganic scale.
Alfa P-Neutra	An alkaline powder for neutralization of used Alfa P-Scale prior to disposal.
AlfaAdd	A neutral cleaning strengthener to be used with AlfaPhos, AlfaCaus and Alfa P-Scale. Provides better cleaning results on oily, fatty surfaces and where biological growth occurs. AlfaAdd also reduces any foaming.
Alpacon Descalant	An acidic, water based, non-hazardous cleaning agent designed for removal of scale, magnetite, algae, humus, mussels, shellfish, lime and rust. Containing BIOGEN ACTIVE, a biological mixture made from renewable materials, as an active ingredient.
Alpacon Degreaser	A neutral degreaser to be used with Alpacon Descalant. Effectively removes oil, fat or grease layers, but also reduces foaming. Containing BIOGEN ACTIVE, a biological mixture made from renewable materials, as an active ingredient.



EN

### Manual cleaning



#### Warning!

To avoid hand injuries owing to sharp edges, protective gloves should always be worn when handling cassettes and protective sheets.

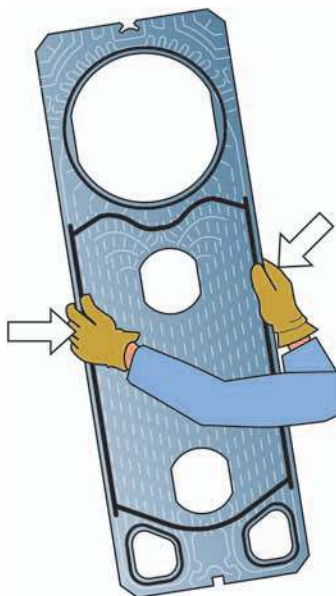

### Opening



#### Warning!

If the plate condenser is hot, wait until it has cooled down to about 40 °C (104 °F).

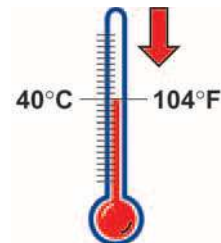

1

Drain the plate condenser.

2

Inspect the sliding surfaces of the carrying bar and wipe clean.

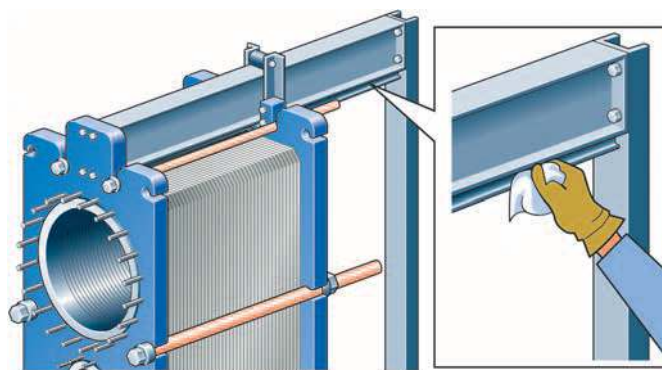

3

Mark the plate assembly on the outside by a diagonal line.

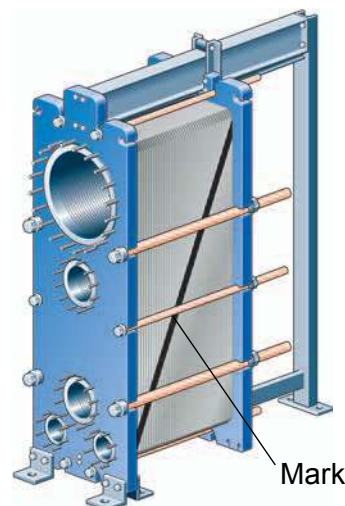



4

Measure and note down the dimension A.

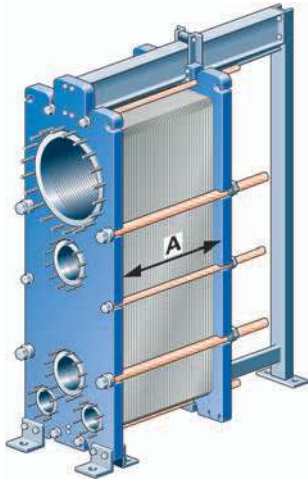

5

Loosen the bolts which are not fitted with bearing boxes and remove them.

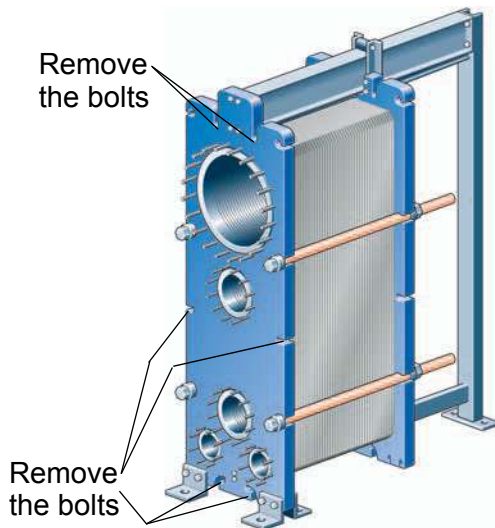

6

The pairs of bolts that are fitted with bearing boxes are opened alternately and diagonally in two steps, see figures below.

EN

Step	Bolt No.	To dimension
1	1 – 2 – 3 – 4	1,05 A
2	1 – 2 or 3 – 4	Opening

Be careful so that the frame plate and pressure plate are always in parallel. Skewing of the pressure plate during opening must not exceed 10 mm (**2 turns per bolt**) across the width and 25 mm (**5 turns per bolt**) vertically.

Step 1: Loosen the four bolts alternately and diagonally until the plate package measures 1,05A.

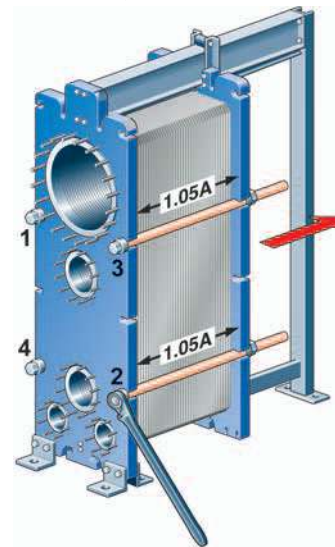

Step 2: Loosen the two diagonal pairs of bolts as shown in the figure below.

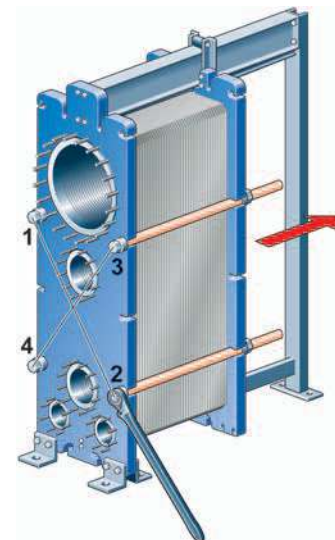



EN

**7** Open the plate pack by letting the pressure plate glide on the carrying bar.

If cassettes are to be numbered, do this before removing the cassettes.

Cassettes need not to be removed if cleaning is done using only water, i.e. without cleaning agent.

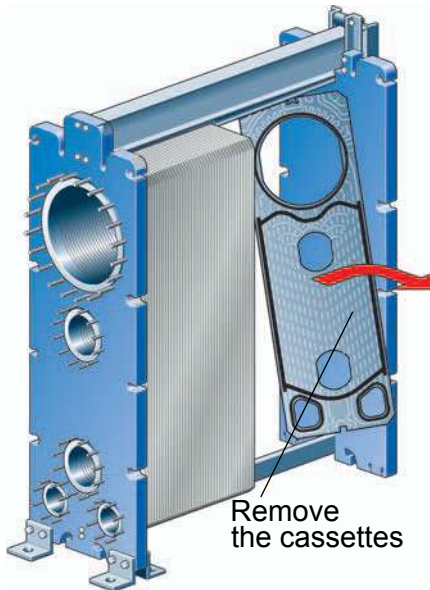



## Manual cleaning of opened units

EN



### Caution!

Never use hydrochloric acid with stainless steel plates. Water of more than 330 ppm Cl may not be used for the preparation of cleaning solutions.



### Note!

Be careful not to damage the gasket during manual cleaning.

### Deposits removable with water and brush

Plates need not to be removed from the plate condenser during cleaning.

- 1 Remove deposits using a soft brush and running water.



- 2 Rinse with water using a high pressure hose.



### Deposits not removable with water and brush

Plates must be removed from the plate condenser during cleaning.

- 1 Brush with cleaning agent.



- 2 Rinse with water.





**Cleaning agents – Incrustation, scaling**  
**Concentration max 4 %**  
**Temperature max 60 °C (140 °F)**

Incrustation – Scaling	Sediment	Cleaning agent
Calcium carbonate	Corrosion products	Nitric acid
Calcium sulphate	Metal oxides	Sulfamic acid
Silicates	Silt	Citric acid
	Alumina	Phosphoric acid
	Diatomic organisms and their excrement of various colours	Complexing agents (EDTA, NTA) Sodium polyphosphates

**Cleaning agents – Biological growth, slime**  
**Concentration max 4 %**  
**Temperature max 80 °C (176 °F)**

Biological growth – Slime	Cleaning agent
Bacteria	Sodium hydroxide
Nematodes	Sodium carbonate
Protozoa	Cleaning effect can be considerably increased by the addition of small quantities of hypochlorite or agents for the formation of complexes and surfactants.



**Caution!**

The following solutions should not be used:

- Ketones (e.g. Acetone, Methyl ethyl ketone, Methyl isobutyl ketone)
- Esters (e.g. Ethyl acetate, Butyl acetate)
- Halogenated hydrocarbons (e.g. Chloroethene, Carbon tetrachloride, Freons)
- Aromatics (e.g. Benzene, Toluene).

**Closing**

EN

- 1** Check that all the sealing surfaces are clean.
- 2** Brush the threads of the bolts clean, using a steel wire brush. Lubricate the threads with a thin layer of grease, e.g. Gleitmo 800 or equivalent.

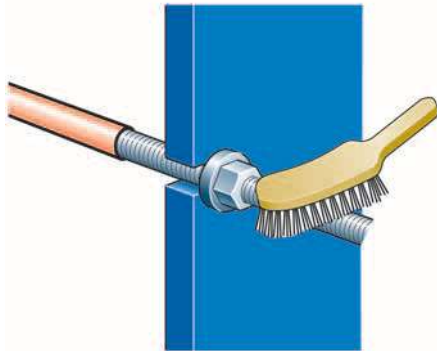

- 3** Attach gaskets to the cassettes or check that all the gaskets are properly attached.

**Note!**

If the gasket is wrongly positioned, it will show by the fact that it rises out of the gasket groove or that it is positioned outside the groove.

- 4** Insert the cassettes with the gaskets turned towards the frame plate.

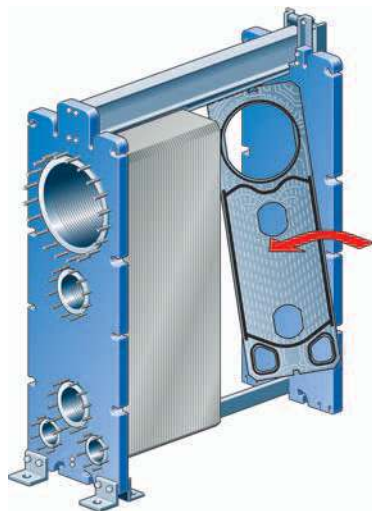

- 5** Press the plate assembly together. Tightening is done in two steps, see figures below. Be careful so that the frame plate and the pressure plate are always in parallel.

Step	Bolt No.	To dimension
1	1 – 2 or 3 – 4	1,10A
2	1 – 2 – 3 – 4	A

Step 1: Tighten the two diagonal pairs of bolts alternately until the plate package measures 1,10A.

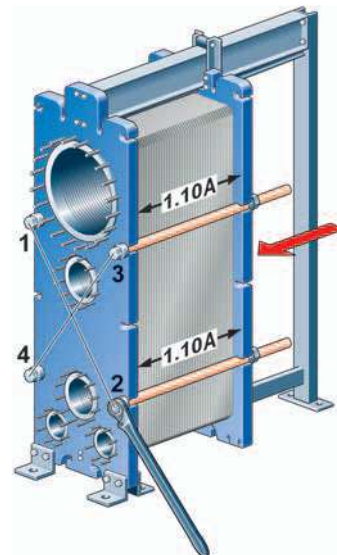

Step 2: After that bolts are tightened alternately and diagonally, as shown in the figure below. Check the dimension A during tightening at the positions of the bolts that are being used.

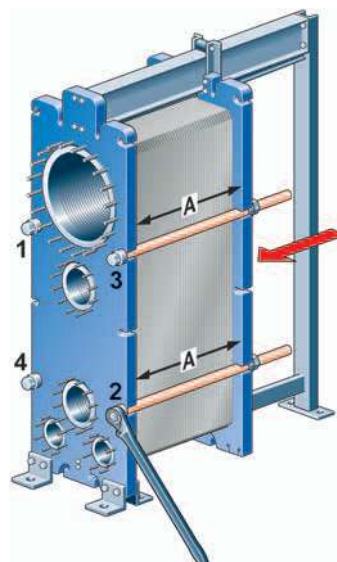

## Max tightening torque

### Note!

When a pneumatic tightening device is used, see table below for maximum torque. Measure dimension A during tightening.

Bolt size	Bolt with bearing box		Bolt with washers	
	Nm	Kpm	Nm	Kpm
M30			900	90
M39	1300	130	2000	200

For manual tightening, the tightening torque has to be estimated.

### If dimension A cannot be reached

- Check the number of cassettes and the dimension A.
- Check that all the nuts and bearing boxes are running freely. If not, clean and lubricate, or replace.

The dimension A can be exceeded to  $A + 1\%$  in exceptional cases.

6

Place the other bolts in position.

- Inspect the washers.
- When fully tightened, the bolts should all be equally tensioned.
- The difference between the plate package lengths (the dimension A) measured at adjacent bolts should not exceed:
  - 2 mm when  $A < 1000$  mm
  - 4 mm when  $A > 1000$  mm.
- The plate package length at all bolts must not differ more than 1 %.
- If the unit does not seal fully, it can be tightened to give dimension  $A-1\%$ .

The maximum tightening torque must not, however, be exceeded.

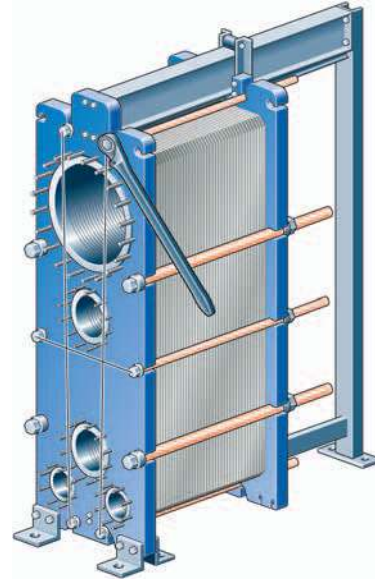

7

If the cassettes are correctly assembled, the edges form a “honeycomb” pattern, see picture below.

If the plate pack has been marked on the outside (see step 3 in section “Opening”), check that the cassettes have been assembled in correct order.

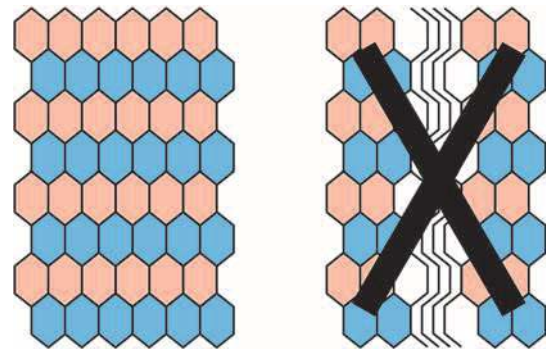

## Regasketing

- 1** Open the plate condenser according to page 8.

EN

### Glued gaskets

- 2** Separate gluing instructions will be delivered together with the glue.
- 3** Close the plate condenser according to page 13.







