



REFRIGERATION CYCLE CONTROLLER FP-MC-23EM

Operation instruction (Software version 1.25)

Safety instruction

- Carefully read the following instruction. Ignoring this instruction may lead to failure of controller and to personnel injuries.
- Operation of controller should be done by qualified personnel which has all the necessary knowledge and skills.
- Please follow the sequence of connections, power polarity and safety rules.
- Follow instruction for connection and controller configuration. Ignoring instruction for connection and controller configuration may lead to it's failure.
- Follow requirements for temperature and humidity of working environment.

General data

Controller designed for superheat maintenance, temperature maintenance in a cooling space and defrost cycle management.

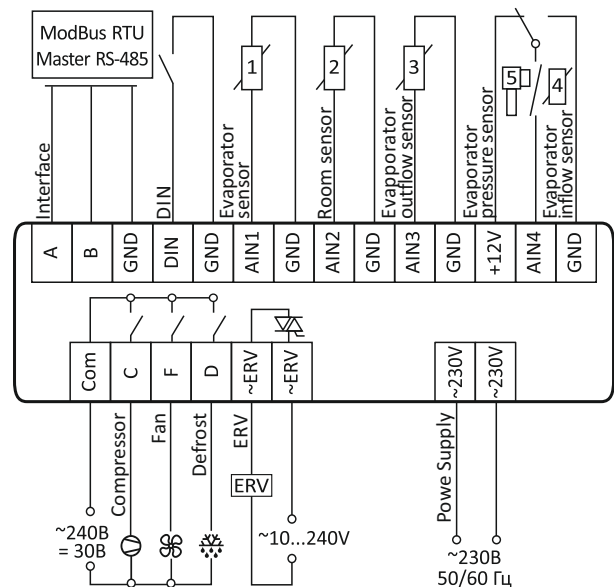
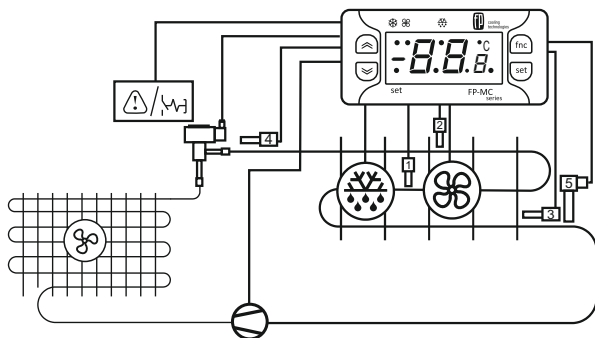

Technical data

Power	~230V ±10%; 50/60 Hz
Consumption	3VA
Size	Installation hole 71x29 mm Panel 77x35.5 mm Dimensions 77x35.5x79 (65,5) mm
Serial port	RS485 Modbus RTU
Environment	-5..+55 °C, humidity 10..90%
Safety class	IP 65 front panel, IP 20 body
Analog inputs	FP-TSN(PX3-42H) range -45..110 °C – 4 pcs.
Discrete input	Clean contact, configured
Relay outputs C, F, D	Ind. load (AC15) 250V/3A, (DC13) 30V/3A Resistive load (AC1) 250V/8A, (DC1) 30V/8A
Electronic Expansion Valve output	Symistor (AC15) 10...230V/1A
Connections	Screws up to 1.5 mm ² with pitch 3.5 mm

Installation

Controller is installed into panel with a notch 71x29mm. Fixation of controller is made with a help of clamps supplied together with controller.

Electrical connections

Connections are made according to the layout shown further in this instruction as well as on controller. Connection of probe to analog input AIN4 is realized according to a type of probe set in SPT parameter (pressure probe or temperature probe). Electromagnetic waves can interfere with the readings of the sensors. Shield the system if necessary. The power supply system of the equipment must be protected against overvoltage. Analog inputs of controller are made for connecting probes of appropriate types only. It is allowed to connect coils of electronic expansion valves of set nominal voltage and power only.

Installation of probes

- AIN1 (1) – evaporator temperature probe – place between blades, closer to upper point of evaporator.
- AIN2 (1) – coldroom temperature probe – place at the center of evaporator.
- AIN3 (3) – temperature probe at outflow of evaporator – place on outcome horizontal tube.
- AIN4 (4)¹⁽²⁾ – temperature probe at inflow of evaporator – place on horizontal part of second turn of evaporator tube
- AIN4 (5)¹⁽²⁾ – evaporation pressure probe – place on suction tube close to temperature probe at outflow of evaporator.

During installation of probes recommended to use metal crimps or thermostable cable ties. Installation of probes on a tube must be done under 45 and 135 degrees. It is recommended to make isolation of probes installed on a tube with a help of thermoinsulation.

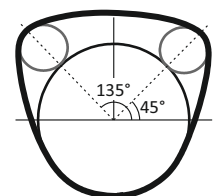

Indications

In "off" state display should show in rotation current selected parameter dIS and sign OFF. In alarm mode display shows in rotation alarm message and current parameter dIS. When door is opened display shows in rotation sign dOr and current parameter dIS.

When changing parameters before indication of parameter display shows it's symbol: tCH – coldroom temperature, tEP – evaporator temperature, tIn – temperature on inflow of evaporator, tOu – temperature on outflow of evaporator, tOH – evaporator superheat temperature, Eru - on-off ratio of electronic expansion valve, Pln – evaporation pressure. In nominal mode indication of working components shown on display as dots (on, off, blinking).

		Compressor "on"			Dripping time
		Compress. run delay, vacuum			Defrost "off"
		Compressor "off"			Fan "on"
		Defrost "on"			Fan "off"

Menu and keyboard

Interface with display and 4 key is used to control state of a system and to set parameters in system menu as well as to turn programming functions. To turn special functions press and hold a key from the main screen for 3 seconds. System has three levels of access. Modification of set point parameters is made from quick menu. Access to set point menu is done by pushing "set" up to 3 seconds. Access to first and second level is done by entering password of first or second level in appropriate window of menu. If password is incorrect display shows PAS and returns to the main screen.

But.	Main function	Secondary func.
	Increase value	On/Off
	Decrease value	Normal/Eco mode
	Escape (Esc)	Defrost
	Entrance. Set.	Menu
		Block

Alarms

A1 – disconnection or short circuit of evaporator probe wires during 10 seconds. System continues working. Defrost is done on schedule and function fan to work depending on evaporator temperature is not working.

A2, A3, A4 – disconnection or short circuit of coldroom probe wires, inflow or outflow of evaporator during 10 seconds. System stops. If probe indication recovers system come back to work.

A5, A6 – superheat is higher AHO or lower ALO during time AOT. System continues working.

A7, A8 – coldroom temperature is higher then set point on AHS or lower on ALS during time AdS. System continues working.

A9 – system in nominal mode cannot reach set point during time Ast. System continues working.

A10 – pressure is lower then APn during Apt using pressure probes. System stops. If pressure is higher APn system come back to work.

A11 – digital inlet dIn state is inverse to dCC during time dIt. System stops. If inlet comes to normal state dCC, system come back to work.

List of parameters

Name	Description	Units	min	max	default	level
SYSTEM						
SYS	Working modes 0 – stop, 1 – always "on", 2 – on/off key		0	2	0	1
SE+	Regulation setpoint	°C	5.5	54.5	2.0	0
SEH	Regulation differential	°C	0.1	20.0	2.0	1
SEC	Economy mode: 0 – nom. mode, 1 – eco mode, 2 – on/off key		0	2	0	1
SES	Economy mode setpoint	°C	5.5	54.5	4.0	1
SEH	Economy mode differential	°C	0.1	20.0	4.0	1
SHS	Maximum volume of setpoint	°C	5.5	60.0	60.0	1
SLS	Minimum volume of setpoint	°C	-60.0	54.5	-60.0	1
SP+	Filling time	sec	0	180	3	1
SP+	Vacuum time	sec	0	180	10	1
SUP	Vacuum pressure ³	bar	-1.0	99.9	1.0	1
SOH	Refrigerant superheat setpoint	K	1.0	50.0	6.0	1
SP	Coefficient P		0.0	99.9	5.0	2
SI	Coefficient I		0	99.9	30	2
LoP	Minimum working pressure ³	bar	-1.0	99.9	-1.0	2
HoP	Maximum working pressure ³	bar	-1.0	99.9	99.9	2
dIn	Configuration of digital input DIN 0 – no, 1 – on/off, 2 – st./eco mode, 3 – door, 4 – defrost, 5 – alarm		0	5	0	2
dCC	Contact configuration of digital input DIN 0 – normal open, 1 – normal close		0	1	0	2
dIt	Time of response on signal from digital input	sec	0	360	0	2
Adr	Address in ModBus network		1	255	1	2
SPd	Speed in ModBus network (8 bit, parity - no, 1 stopbit). 1 – 1200, 2 – 2400, 3 – 4800, 4 – 9600, 5 – 19200, 6 – 28800, 7 – 38400, 8 – 43000, 9 – 56000, 10 – 57600, 11 – 115200, 12 – 128000	bit/sec	1	12	5	2
dS	Display 0 – manual, 1 – room temperature, 2 – evaporator temperature, 3 – inlet temperature, 4 – outlet temperature, 5 – superheat, 6 – on/off rate ERV, 7 – set point, (8 – evaporator temperature) ³		0	7(8) ³		1
SE1	Calibration of temperature probe on evaporator	°C	-10.0	10.0	0.0	1
SE2	Calibration of temperature probe in coldroom	°C	-10.0	10.0	0.0	1
SE3	Calibration of outflow temperature probe	°C	-10.0	10.0	0.0	1
SE4 SP4	Calibration of inflow temperature probe (Calibration of pressure probe) ³	°C bar	-10.0 -2.0	10.0 2.0	0.0 0.0	1
SPE	Type of inlet probe AIN4 1 – temp. probe FP-TS-N, 2 – pressure probe FP-PT-10 3 – pressure probe (user's settings)		1	3	2	2

Name	Description	Units	min	max	default	level
SPL	Lower measurement limit of pressure probe (SPL=3)	bar	-1.0	5.0	0.0	2
SPH	Upper measurement limit of pressure probe (SPH=3)	bar	0.0	99.9	0.0	2
SPF	Refrigerant type 0 – R22, 1 – R134A, 2 – R404A, 3 – R407C, 4 – R410A, 5 – R507, 6 – R744, 7 – R12, 8 – R502, 9 – R717, 10 – R600, 11 – R23, 12 – R290, 13 – R142B, 14 – R406A, 15 – R409A, 16 – R448A, 17 – R449A		0	17	0	2
Fnc	Programming key «fnc» 0 – no, 1 – defrost		0	1	0	2
LOC	Blocking keyboard: 0 – off, 1 – on		0	1	1	2
COMPRESSOR						
COP	First run delay	sec	0	999	10	2
COH	Minimum working time	sec	0	999	30	2
COF	Минимальное время останова	sec	0	999	0	2
COO	Turning cycling	sec	0	999	600	2
FAN						
FOC	Operation together with Electronic Expansion Valve. 0 – always on, 1 – working together with ERV		0	1	0	1
FCT	Control of evaporation temperature 0 – off, 1 – on		0	1	0	1
FOH	Temperature of turning off	°C	-50.0	30.0	0.0	1
FFH	Differential of turning off	°C	0.1	30.0	5.0	1
ELECTRONIC EXPANSION VALVE						
EPR	Period	sec	3	16	6	2
ELL	Minimum on/off rate of Electronic Expansion Valve	%	0	EHL	10	2
EHL	Maximum on/off rate of Electronic Expansion Valve	%	ELL	100	100	2
ESL	Starting state	%	ELL	EHL	75	2
DEFROST						
dDH	Delay of first defrost	min	0	999	0	1
dPr	Defrost interval	10min	0	999	18	1
ddr	Duration of defrost	min	0	180	30	1
dE	Finish temperature	°C	-30.0	50.0	10.0	1
dnC	Defrost mode: 0 – natural, 1 – electric		0	1	1	2
dSC	Start from defrost after turning on 0 – off, 1 – on		0	1	0	2
dDF	Fan delay time	sec	0	999	20	1
dd	Period of dropping (flow down of drops)	min	0	30	10	1
dFE	Defrost depending on evaporator probe AIN1: 0 – off, 1 – on		0	1	1	2
dFd	Fan working during defrost: 0 – off, 1 – on		0	1	0	2
dd	Indication during defrost: 0 – Temperature in coldroom, 1 – temperature before defrost, 2 – dEF		0	2	1	2
ACCESS						
Pr1	First level access password		0	999	000	2
Pr2	Second level access password		0	999	010	2
rST	Reset to default settings(YES, NO)		NO	YES	NO	2
ALARMS						
AHS	Temperature excess over setpoint	°C	2	30	30	2
ALS	Temperature drop lower setpoint	°C	2	30	30	2
AdS	Time of delay excess/drop of temperature ⁴	min	0	360	0	2
APL	Runtime till standard mode (waiting for setpoint) ⁴	h	0.0	99.0	0.0	2
ALO	Minimum superheat	K	0.0	AHO	0.0	2
AHO	Maximum superheat	K	ALO	50.0	50.0	2
AOT	Waiting time for superheat ⁴	min	0	999	0	2
APn	Minimum pressure ³	bar	-1.0	99.9	0.0	2
APL	Waiting time for minimum pressure ³⁽⁴⁾	sec	0	999	1.0	2

This instruction is a description of functions for experienced users.

1 – as evaporation probe it is recommended to use pressure probe due to it's lower persistence in comparison to temperature probe;

2 – manufacturer is not responsible for correct operation of controller if non original temperature (FP-TSN) and pressure (FP-PT) probes are used;

3 – parameters available if configuration with pressure probe is used;

4 – setting 0 for temporary parameters turns off alarm running.