

HDB3 stainless steel oil receiver

Manual



TH. WITT Kältemaschinenfabrik GmbH

Lukasstrasse 32, D-52070 Aachen

Tel. +49-241-18208-0, Fax. +49-241-18208-490

<https://www.th-witt.com>, sales@th-witt.com

State of documentation: August 2019

3133-603_E_2019_08

Content

1. INTRODUCTION	3
1.1 Intended use	3
1.2 Safety Requirements	3
1.3 Disclaimer	4
2. TERMS OF WARRENTY	4
3. TECHNICAL INFORMATION	5
3.1 Scope of delivery	5
Optional scope of delivery	5
4. TECHNICAL DATA	5
4.1 Materials	5
4.2 Zugelassene Medien	6
4.3 Dimensions	6
4.4 Sectional Views	6
4.6 FUNCTIONAL DESCRIPTION	7
4.7 Oil collection tank and drain vessel	7
4.8 Oil collection and distribution vessel	8
5. TRANSPORT AND STORAGE	9
6. ASSEMBLY	9
7. COMMISSIONING	10
7.1 Before commissioning	10
8. OPERATION	10
9. MAINTENANCE AND INSPECTION	10
10. OPTIONAL FILL LEVEL SENSOR	11
10.1 Mechanical installation	11
11. OPTIONAL CRANKCASE HEATER	12
11.1 Mechanical installation	12

1. INTRODUCTION

Please read the entire manual carefully before selecting, installing, commissioning and servicing the HDB.





1.1 Intended use

The HDB oil collector is used exclusively for collecting settling, insoluble refrigerant oil in refrigerant circuits. For low-temperature applications, the oil in the HDB can be heated up.

1.2 Safety Requirements

All the work carried out on refrigeration systems must be performed by qualified personnel, trained in handling refrigeration systems. The safety regulations and accident prevention measures that apply to the handling of refrigerants must be observed.

The applicable guidelines for setting up and operating refrigeration systems, e.g. EN 378, must be observed. The legal regulations governing the commissioning and operation of pressure equipment valid at the site of the respective country must be followed. Under no circumstances may temperature and pressure information specified on the nameplate and drawings be exceeded.

	Pressure vessels that can be shut off by other parts of the refrigeration system must be equipped with a pressure relief device to prevent an unacceptable increase in pressure in accordance with EN 378.
	Welding work must not be carried out on the pressure vessel (other than on the designated connections), otherwise this will render the certificates invalid.
	If an electric heating element is used, a qualified electrician must carry out the electrical connection in accordance with the relevant safety regulations. It must be taken into account that condensation will form on the surface of the HDB.
	In order to protect people from burns or frostbite, a form of protection must be provided depending on the temperature (below -10°C or above $+60^{\circ}\text{C}$), e.g. insulation.

The corresponding fire safety precautions must be taken to prevent the pressure vessel from overheating.

The safety devices must be checked before commissioning the system. The safety devices must also be inspected after the system is disassembled or after a reaction.

1.3 Disclaimer

Even when using the pump for the intended purpose it cannot be entirely excluded that a danger may remain during its working lifetime.

Translations have been made to the best of our knowledge. We are unable to accept any liability for errors in translation.

We reserve the right to change descriptions, graphs and technical information due to future development of the product.

2. TERMS OF WARRENTY

In order to avoid accidents and to ensure the safety of the system, no modifications or changes may be made to the HDB that have not been expressly approved by TH. WITT KÄLTEMASCHINENFABRIK GmbH.

All the information and instructions for the operation and maintenance of the pressure vessel are made to the best of our knowledge, based our previous experience and knowledge.

All liability or warranty claims are excluded if:

- the references and instructions in the operating manual are not observed,
- the HDB, including its equipment, is not operated correctly, or it has been handled in a way that does not correspond to the prescribed sequence,
- the HDB is used for purposes other than its intended use,
- safety devices are not used or are disabled,
- functional changes of any kind are made without our written consent,
- the relevant safety regulations and accident prevention regulations are not observed during the operation of the HDB.



3. TECHNICAL INFORMATION

3.1 Scope of delivery

- HDB vessel made of steel, manufactured according to AD2000 and DGRL
- Connection DN40 for refrigerant / oil mixture (ON400)
- Connection DN25 for safety valve (ON610)
- Connection DN40 connection BDP / distribution (ON410)
- Connection DN25 for equalisation line/reserve (ON611)
- Connection G $\frac{1}{2}$ " min and max. level + screw plugs (ON520/21)
- Oil drain plug with EA10GB/VA (ON500)
- SSV6 quick-closing valve connection to EA10 (loose)
- Thermowell G $\frac{1}{2}$ " connection for optional electrical heater element (ON510)
- Mounting sockets M12 top/bottom
- Mounting brackets incl. fastening material

Optional scope of delivery

- Electrical heating elements 200 W
- Oil sensor G $\frac{1}{2}$ "
with encased gasket
for installation into min/max connections
- Overflow valve
- BDP for automatic
oil return incl. connection valve
- EA10GBL/VA for the pressure gauge
- Pressure gauge with stand

4. TECHNICAL DATA

Total volume	[ltr]	39
Max. filling capacity	[ltr]	34
Usable volume	[ltr]	30
Test pressure	[bar]	42,6
Permissible operating pressure	[bar +100°C / -10°C]	25
	[bar -10°C / -60°C*]	18,75

4.1 Materials

Housing	1.4541 / 1.4301
Nozzles	1.4541

4.6 FUNCTIONAL DESCRIPTION

The HDB can be as a collection container for the refrigerating machine oil which settles in the refrigerant separator.

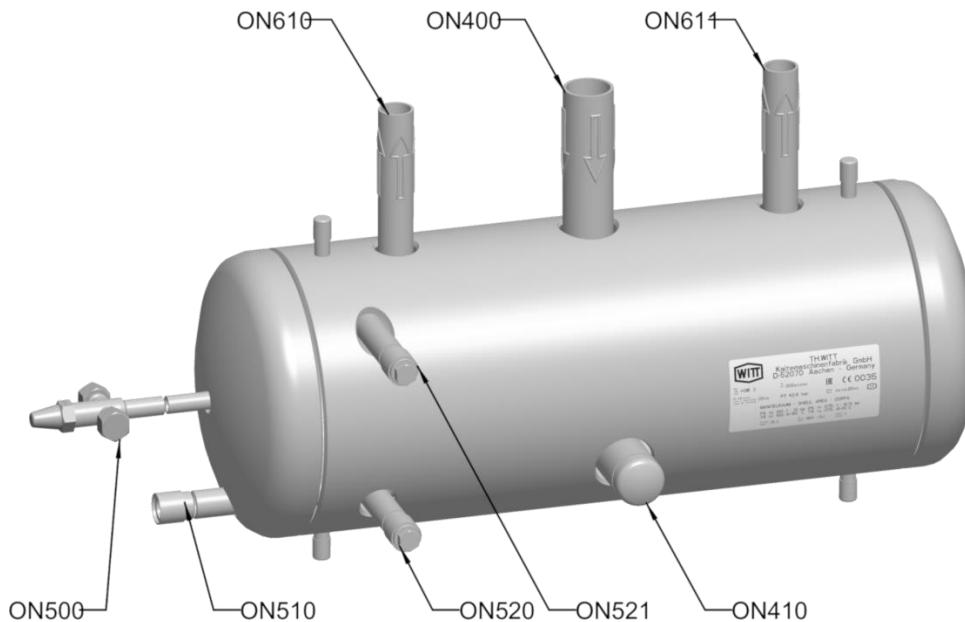

4.7 Oil collection tank and drain vessel

To drain the oil, the shut-off valves (ON400 inlet line) and (ON611 equalisation line) need to be closed. Because of the heat input from the surrounding environment, a pressure builds up in the HDB which means the oil can be discharged through the oil drainage valve (ON500) and quick-closing valve. To speed up the process there is the option of attaching a heating element (ON510). After the oil has been drained, the shut-off valve (ON400) and (ON611) need to be opened again. The safety relief valve (ON610) must be used to ensure that there is no impermissible increase in pressure (above 25 bar) in the vessel. There is also the option of using the gauge connection (ON520) and (ON521) to check the oil level (MIN/MAX).

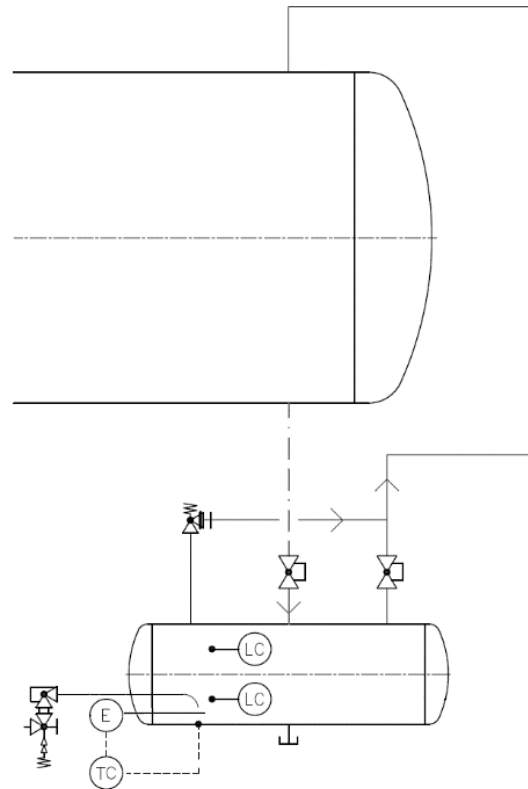

4.8 Oil collection and distribution vessel

To use the HDB as an oil distribution vessel (for returning the oil to the compressor), you must use the functions and controls of the distribution connections (ON410). (ON410) as described in section 6.1. If there is not enough pressure in the collection vessel to return the oil to the compressor, the oil can also be driven out by means of a hot gas connection set up by the customer. Alternatively, the automatic oil return system (BDP) can also be connected to connection (ON410). In this case the oil is also removed using pressure (refer to the BDP operating manual). The special procedures must be observed when returning oil from screw and/or piston compressors (manufacturer's documentation). To return the oil automatically, all the valves can be equipped with actuators and the optional level monitoring device (ON520 / min) and (ON521 / max) can be used as an additional control variable.

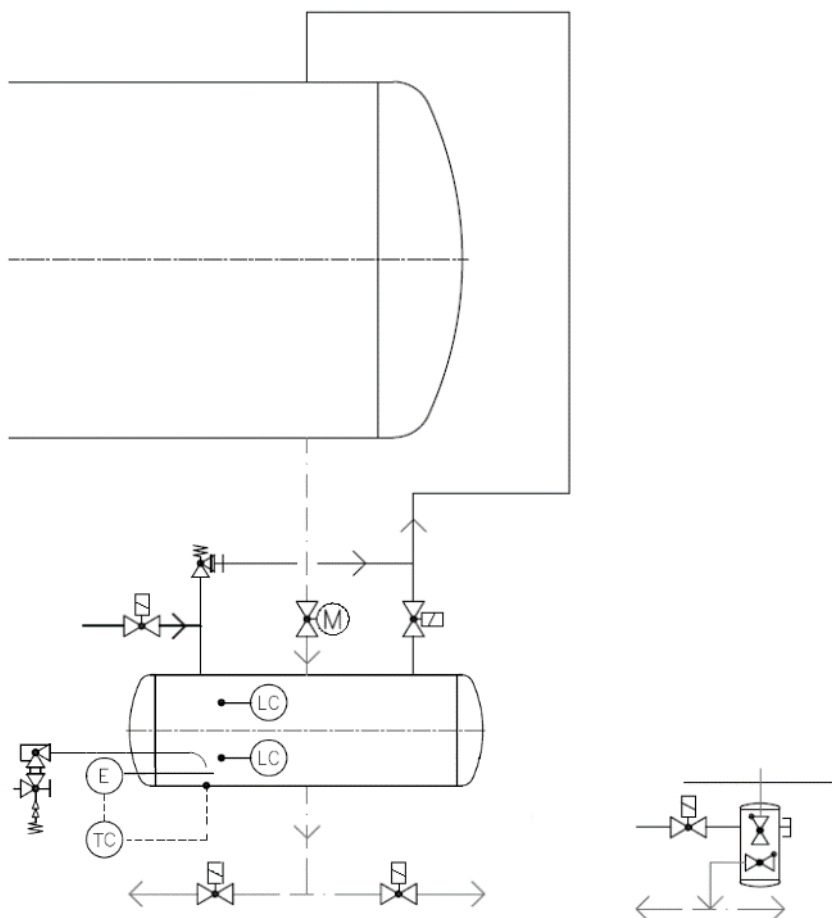

5. TRANSPORT AND STORAGE

All openings (connections, etc.) are fitted with yellow plastic protective caps to prevent the entry of water, dirt particles, etc.

It should be stored in a dry location and protected from dirt. If the HDB is to be stored for more than two months or it has to be transported overseas, the HDB can optionally be filled with inert gas to protect it for reasons of a possible condensate formation.

If the HDB oil collector has been filled with inert gas in the factory, the bleeder chokes must be removed immediately before the HDB is incorporated into the refrigeration circuit. It is important that no grinding chips or dirt get into the surface or into the HDB! If necessary, the pressure vessel should be thoroughly cleaned inside and outside.

During transport, the mounting sockets M12 can be used together with an eyebolt – by way of example. If other transport and lifting devices are used, it must be ensured that the vessel and connections are not damaged / bent.

6. ASSEMBLY

Packing material and the yellow plastic protective caps used to protect all openings (connections, etc.), must be removed immediately before assembly.

Please follow the instructions on the drawings relating to the order when assembling the system! The refrigeration engineer responsible for the planning has to ensure that the necessary equipment with safety devices and control elements is adapted to the individual requirements.

The HDB is designed to be installed in buildings. (Earthquakes, traffic, wind and snow loads are not included in the statics). It is only possible to install the system externally with the written permission of TH. WITT KÄLTEMASCHINENFABRIK GmbH.

Ensure there is sufficient space for inspections, maintenance work and insulation. The discharge valves, safety valves and quick-release valves must be easily accessible.



All the exhaust lines must be routed in accordance with the recognised rules of engineering (e.g. EN 378) so that nobody is put at risk.



It is important to ensure that the inlet of the separator is placed at the lowest point of the separator so that the oil can flow freely to the HDB.



When welding the piping to the connections (or valves) provided for this purpose, ensure that the installation is not under and strain or stress!



No additional forces may be applied to the connections or the HDB.



If a heating element is used, then thermal transfer paste should be used to improve the transfer of heat.

7. COMMISSIONING

Die Inbetriebnahme des HDB darf erst erfolgen, wenn eine Sicherheitsanalyse der Gesamtanlage vorgenommen wurde.

7.1 Before commissioning

After it has been assembled, the entire pipeline system must undergo a thorough visual inspection. All the screwed and flanged connections must be tightened. A leak and pressure test must then be carried out and documented. At this stage, particular attention should be paid to the welded seams created after the factory test and to any flanged or screwed connections.

Before commissioning it must be checked, in particular, that:

- all the piping has been connected according to the technical drawings
- the necessary safety devices have been installed and tested

8. OPERATION

The HDB may only be operated within the range of its design data.

The pressure relief device must be set up and adjusted according to the rules and standards / local regulations (this must never exceed the max. permissible pressure as specified on the nameplate!)

The pressure device is designed for predominantly static pressure loads with a maximum of 1000 full load changes. The range of the change in pressure must not exceed 10% of the maximum permissible pressure.



Regularly check that the safety valve (ON610) is working properly! This is particularly important before the oil drains through the quick-closing valve in order to avoid risks and injuries.

9. MAINTENANCE AND INSPECTION

The inspection of the HDB, including the safety devices attached, must be carried out on a regular basis in accordance with the applicable legal provisions and/or regulations and technical rules and standards.



If maintenance work has to be carried out on the HDB, the pressure must be released from the system and the refrigerant must be completely sucked out before any screwed connections are loosened. Under no circumstances must you remove all the screws when any refrigerant or pressure is still in the system.



The HDB has to undergo, for example, a visual inspection on a regular basis, in accordance with DIN EN 378-2. (This includes, for example, an external visual inspection for corrosion.)

The corrosion allowance for pressure-bearing components made of stainless steel is 0 mm.

10. OPTIONAL FILL LEVEL SENSOR



A detailed description of the sensor can be found in the manufacturer's operating manual. The operating manual for HDB3 (W3133-6.03) is only valid in conjunction with the manufacturer's operating manual already mentioned.

10.1 Mechanical installation

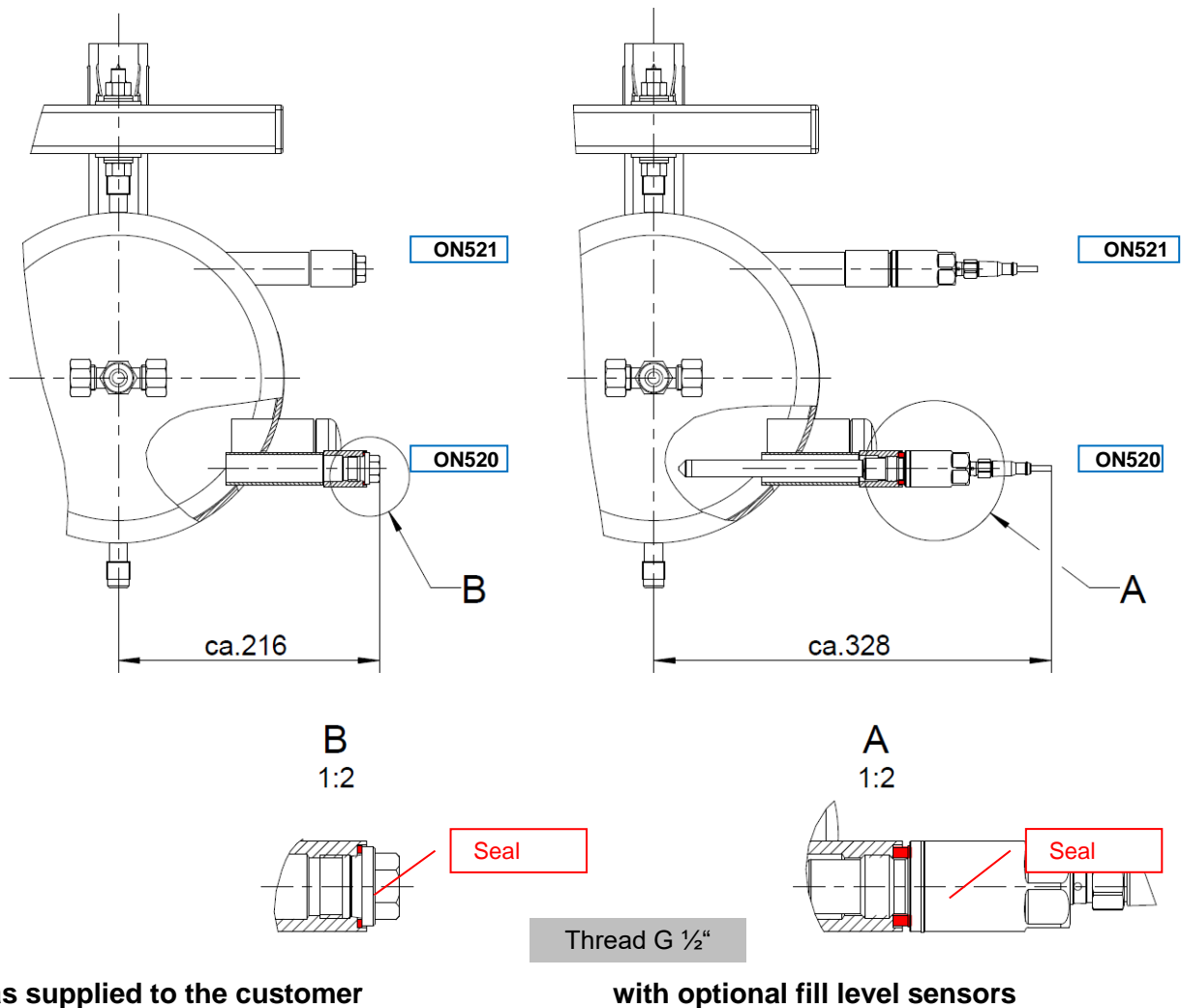

When installing the level sensor, the following points must be noted:

- Remove the screw plug and O-ring (the vessel must be depressurised!).
- Do not use any additional sealing material (e.g. PTFE tape). The sensor must have electrical contact with the metallic process connection.
- Lightly grease the thread of the sensor with a lubricant that is suitable and approved for the respective application.
- The sensor is supplied with a pre-mounted sealing system.
- The max. tightening torque (hexagon SW27) is 20 ... 25 Nm.
- Check the HDB for leaks after it has been installed.

11. OPTIONAL CRANKCASE HEATER



A detailed description of the crankcase heater can be found in the manufacturer's operating manual. The operating manual for HDB3 (W3133-6.03) is only valid in conjunction with the manufacturer's operating manual already mentioned.

11.1 Mechanical installation

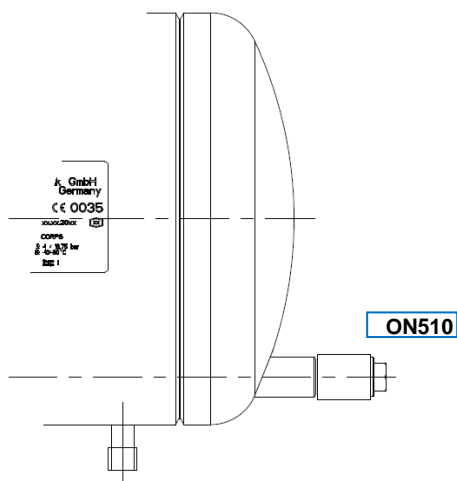

as supplied to the customer

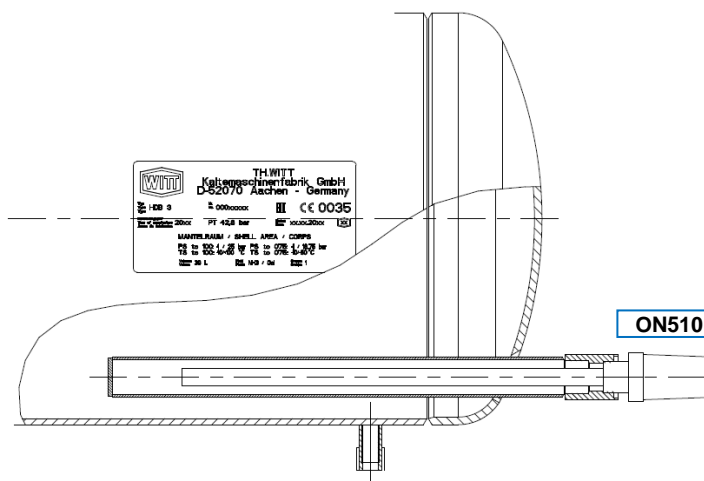

with optional fill level sensors

When installing the crankcase heater:

- Remove the screw plug and O-ring
- Lightly grease the threads of the crankcase heater with a lubricant that is suitable for the respective application.
- Use thermal transfer paste for improved transfer of heat.