

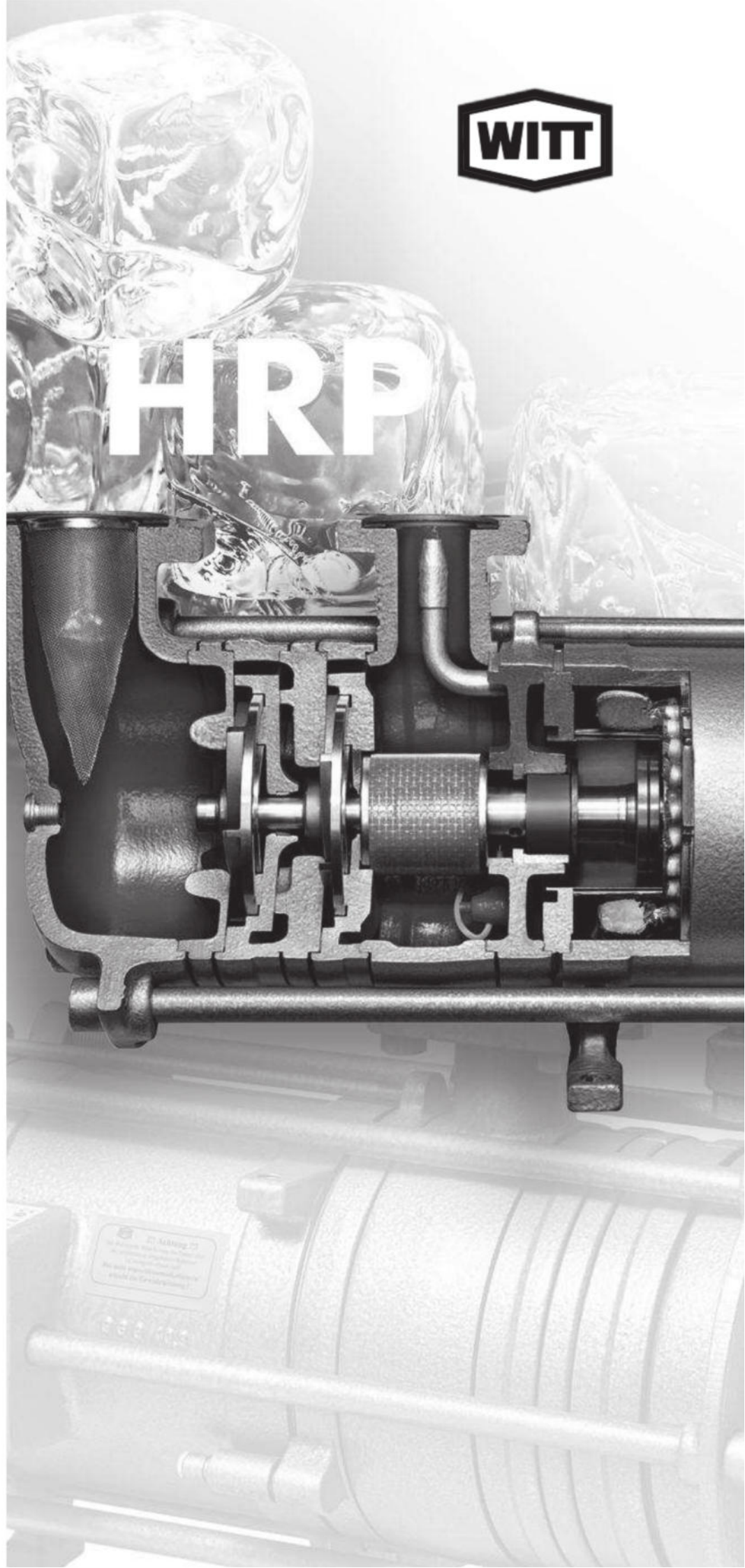

**Hermetic
refrigerant pumps**
*Installation and
operating instructions*

HRP 3232
HRP 5040
HRP 5050
HRP 8050
HRP 10080

HRP



Content

1. INTRODUCTION	1
1.1 INTENDED USE	1
1.2 SAFETY REQUIREMENTS	1
1.3 SAFETY ADVICE	2
1.4 DISCLAIMER	2
2. TERMS OF WARRANTY	3
3. TECHNICAL INFORMATION	4
3.1 DESCRIPTION OF TYPES	4
3.2 SCOPE OF DELIVERY	4
3.3 ORDER INFORMATION	5
3.4 CODES / CERTIFICATES / APPROVALS	5
4. TECHNICAL DATA	6
4.1 GENERAL INFORMATION	6
4.2 ELECTRICAL DATA	6
4.3 MATERIALS	10
4.4 PRESSURE RANGE	10
4.5 DIMENSIONS	12
4.6 SECTIONAL VIEWS	14
4.7 DESCRIPTION OF OPERATION	35
4.8 PERFORMANCE CHARACTERISTIC TABLE	35
5. APPLICATIONS	37
5.1 GENERAL	37
5.2 DETERMINATION OF THE DELIVERY HEAD	38
5.3 DETERMINATION OF THE REQUIRED FLOW	38
5.4 ADAPTATION TO PLANT REQUIREMENTS	39
5.5 USE OF FREQUENCY CONVERTERS	40
6. INSTALLATION INSTRUCTIONS	41
6.1 PUMP ARRANGEMENT	41
6.2 PUMP CONNECTION	41
6.3 DOWNLEG DESIGN	43
6.4 PUMP DISCHARGE LINE	44
6.5 PROTECTION OF THE PUMP	45
6.6 ELECTRICAL INFORMATION	49

7. TRANSPORT AND STORAGE	55
8. INSTALLATION AND APPLICATION	56
8.1 PREPARING THE PUMP FOR INSTALLATION	56
8.2 MOUNTING INSTRUCTIONS	56
8.3 PRIOR TO COMMISSIONING	58
8.4 COMMISSIONING PROCEDURE	58
8.5 DURING NORMAL OPERATION	59
8.6 PUMP STANDSTILL (STAND-BY)	59
9. SERVICE AND MAINTENANCE	60
9.1 REMOVING A PUMP	60
9.2 SHIPPING OF THE PUMP	60
9.3 GENERAL ADVICE	60
9.4 REPAIRING A PUMP	61
9.5 WARNINGS	61
10. TROUBLE SHOOTING	63



TH. WITT Kältemaschinenfabrik GmbH

Lukasstrasse 32, D-52070 Aachen

Tel. +49-241-18208-0

<https://www.th-witt.com>, <mailto:sales@th-witt.com>

Status of documentation: February 21th, 2022

1. INTRODUCTION

Please read the entire manual careful before selecting, installing, commissioning and servicing the pump.

1.1 INTENDED USE

The WITT hermetic refrigerant pump type is designed to deliver exclusively refrigerant liquid at its boiling point.



Refrigerant pumps constitute partly completed machinery within the meaning of the Machinery Directive 2006/42/EC.

They can only be operated if they have been properly assembled with other parts, considering all safety instructions to form a complete system.

The pump is labelled with model and design limitation for pressure and temperature.

The HRP refrigerant pump is designed with safety features, which ensures security from the escape of ammonia; in the event the stator can leaking the pump body and the complete motor housing is designed to 25 bar pressure to contain high pressure refrigerant will not escape from the pump or through the electric cable connections.

Performance data of the pump are to be found in chapter 4 Technical data.

1.2 SAFETY REQUIREMENTS



All of the following specified work must be carried out by knowledgeable personnel experienced in installation and service of refrigeration systems. All personnel must be familiar with the national legal requirements and safety regulations. All safety regulations and codes of practice concerning the use of refrigerants must be adhered to, with special attention paid to protection clothing and wearing of safety glasses.



Service and maintenance should only be carried out when the pump is stopped and the power supply disconnected.



Under no circumstances are the indicated temperature- and pressure limitations to be exceeded.



Important! The content of this manual must be adhered to. Deviation from the specified conditions will make any claim for liability or warranty void.

1.3 SAFETY ADVICE

The pump is designed for use in industrial refrigeration systems of primary refrigerant.

Refrigerant is used to cool motor and bearings. Any gas that forms in the pump is discharged to the pressure side. The electrical power consumption of the pump is low in relation to the refrigeration capacity, due to the effect of the latent heat of the liquid being utilised.



It is very important that everybody responsible for the safe operation and maintenance of the plant reads this manual.

If you have any problems please do not hesitate to call our service department, our staff will be glad to assist you.

Avoid any tripping obstacle at ground levels, e.g. cable. If you cannot avoid such obstacles they should be marked with two-coloured warning tape (warning sign).

Retighten all screw connections after maintenance and repair work!

If you have to disassemble any safety devices for maintenance and repair make sure that upon completion of said work the re-assembly and proper functioning is checked!

When operating at low temperatures ($< 0^{\circ}\text{C}$) freeze bites can occur when the surface is touched. Therefore always wear appropriate protection clothing.

1.4 DISCLAIMER

Even when using the pump for the intended purpose it cannot be entirely excluded that a danger remains for the life of the user. Translations are carried out to the best of our knowledge. We are unable to accept any liability for translation errors.

We reserve the right to change descriptions, graphs or other statements.

2. TERMS OF WARRANTY

In order to avoid accidents and ensure optimum performance, no modifications or conversions may be carried out to the refrigerant pump without the explicit written approval by TH. WITT KÄLTEMASCHINENFABRIK GMBH.

These instructions are based on internationally standardised SI units of measurements.

All data and information on the operation and maintenance of the refrigerant pump is provided based on our extensive experience and to the best of our technical knowledge.

Our liability or warranty is excluded, if:

- information and instructions in the operating manual are ignored,
- the refrigerant pump including accessories is operated incorrectly or is installed contrary to these installation instructions
- the refrigerant pump is used for applications other than that for which it was intended,
- safety devices are not used or disconnected
- there have been modifications made without written approval
- the safety regulations are not adhered to
- the refrigerant pump including its filters and required safety devices has not been maintained or repaired correctly with respect to frequency or competence this includes the use of approved spare parts.



Opening the pump within the warranty period will void all implied or explicit guarantees!

Always return the pump to the supplier for repair or order an exchange pump.

When exchanging any parts respective spare parts only genuine spare parts are to be used.

Statements in this manual shall also apply to any service fluids.

3. TECHNICAL INFORMATION

3.1 DESCRIPTION OF TYPES

Five hermetic pump types are available: HRP3232, HRP5040, HRP 5050, HRP 8050; HRP 8050-2 and HRP10080.

"HRP" means "Hermetic Radial Pump" The numbers give the inlet and outlet pipe connection size in DN; the first two/three digits give the size of the suction connection while the last two digits give the size of the discharge connection.

In addition to the HRP3232, which is only available in vertical design, the HRP 5050-90 and 8050-90 for 90bar standstill pressure are also offered in vertical design.

The HRP 5050-90 and 8050-90 are supplied without a can and are therefore only suitable for use in CO₂ systems.



The HRP 8050-2 is specifically for Freon refrigerants.

Due to the higher viscosity of Freon refrigerants, this model has a more powerful motor (same motor as the HRP 10080).

3.2 SCOPE OF DELIVERY

- Refrigerant pump complete with canned motor, suction strainer (model 0)
- The HRP 3232 also includes an EA 10 GÜ/GB (PN 40) drain valve

Optional scope of delivery

- Counterflange on suction side
- Counterflange on discharge side
- Shut-off valve on suction side (from HRP 5040)
- Through ball valve on suction side (only HRP 3232)
- Shut-off valve on discharge side with counter flange, vent valve (manometer connection) and cam for differential pressure switch. Cam not with HRP 3232
- lockable check valve on the pressure side with counter flange, vent valve (manometer connection) and cam for differential pressure switch. Cam not with HRP 3232
- Oil drain valve EA 10 GÜ/GB (PN 40) (already included with HRP3232)
- NH3 pressure gauge with stand (12.5 bar or 25 bar)
- PTC motor control INT 69 V (110 V or 230 V)

3.3 ORDER INFORMATION

Please specify the following data when ordering a pump:

- refrigerant
- type HRP 3232, HRP 5040, HRP 505, HRP 8050, HRP 8050-2 or HRP 10080
- Model, e.g. GF ,2 x EA or EA +ERA
- Voltage and frequency.
- (Special requirements if applicable, e.g. PN 65 for HRP 3232 or PN 90 for HRP 5050/8050)

If you are unsure about the selection, please provide the following additional information:

- evaporating temperature°C
- volume flow m³/h or capacity and re-circulation rate
- required pressure head m

3.4 CODES / CERTIFICATES / APPROVALS

The following certifications are available and can be downloaded from our website www.th-witt.com:

declaration of incorporation of a partly completed machinery according to EG machinery directive, conformity declaration according to EU- low voltage directive.

4. TECHNICAL DATA

4.1 GENERAL INFORMATION

DESCRIPTION	Unit	HRP 3232	HRP 5040	HRP 5050	HRP 8050	HRP 10080
Volume refrigerant side	ltr.	1,1	2,8	5	5,5	6,35
Volume transformer oil	ltr.	0,75	1	1,5	1,5	1,6
Weight pump with counterflanges	kg	43	55	83	83 / 110**	117
Sound pressure level	dB(A)	< 70	< 70	< 70	< 70	< 70
Class of terminal box insulation	IP	54	54	54	54	54
Box cable sockets prepared to	PG	1 x M16; 1 x M20	1 x M16 1 x M20	1 x M16 1 x M20;	1 x M16 1xM20/M25 **	1 x M16 1 x M25

** Model HRP8050-2, Model HRP 5050-90 and 8050-90

4.2 ELECTRICAL DATA

(applies to all pressure stages)

50 Hz 3 x 400 V								
DESCRIPTION	Unit		HRP 3232	HRP 5040	HRP 5050	HRP 8050	HRP 10080	
Speed	n	[min ⁻¹]	2900	2900	2900	2900	2900	
max. power consumption								
with NH ₃	I _{max}	[A]	1,5	4,7	5,5	7,0	13,0	
with CO ₂	I _{max}	[A]	2,1	-	7,0	10,0	16,0	
With HFC, HFO, e.g. R134a	I _{max}	[A]	2,2	5,2	8,5	16,0**	20,0	
Motor power factor								
with NH ₃	Cos φ	[-]	0,61	0,63	0,68	0,80	0,79	
with CO ₂	Cos φ	[-]	0,83	-	0,80	0,88	0,85	
With HFC, HFO, e.g. R134a	Cos φ	[-]	0,84	0,63	0,85	0,85**	0,89	
Effective motor power	N	[kW]	$N_{\text{wirk}} = \sqrt{3} \times (U \times I_{\text{wirk}} \times \cos \varphi)$ (values at operating point – see selection tool)					

60 Hz 3 x 460 V								
DESCRIPTION	Unit		HRP 3232	HRP 5040	HRP 5050	HRP 8050	HRP 10080	
Speed	n	[min ⁻¹]	3500	3500	3500	3500	3500	
max. power consumption								
with NH ₃	I _{max}	[A]	2,0	6,2	7,3	10,0	16,0	
with CO ₂	I _{max}	[A]	2,6	-	9,5	16,0	24,0	
With HFC, HFO, e.g. R134a	I _{max}	[A]	2,9	6,9	11,5	23,5**	28,0	
Motor power factor								
with NH ₃	Cos φ	[-]	0,88	0,86	0,87	0,90	0,90	
with CO ₂	Cos φ	[-]	0,92	-	0,90	0,90	0,93	
With HFC, HFO, e.g. R134a	Cos φ	[-]	0,93	0,86	0,91	0,85**	0,93	
Effective motor power	N	[kW]	$N_{\text{wirk}} = \sqrt{3} \times (U \times I_{\text{wirk}} \times \cos \varphi)$ (values at operating point – see selection tool)					

* Measure the maximum current during commissioning and set the overload protection to this value, do not exceed I_{max} for the relevant refrigerant.

** The HRP8050-2 model requires a special motor for Freons and HFO, e.g. R134a with the dimensions and data of the motor for an HRP10080.

FURTHER MOTORS

50 Hz 3 x 380 V								
DESCRIPTION	Unit		HRP 3232	HRP 5040	HRP 5050	HRP 8050	HRP 10080	
Speed	n	[min ⁻¹]	2900	2900	2900	2900	2900	
max. power consumption								
with NH ₃	I _{max}	[A]	1,7	5,2	5,8	8,5	14,0	
with CO ₂	I _{max}	[A]	2,3	-	7,6	12,6	18,0	
With HFC, HFO, e.g. R134a	I _{max}	[A]	2,6	7,2	9,0	16,9**	21,0	
Motor power factor								
with NH ₃	Cos φ	[-]	0,84	0,63	0,85	0,85	0,89	
with CO ₂	Cos φ	[-]	0,84	-	0,85	0,85	0,89	
With HFC, HFO, e.g. R134a	Cos φ	[-]	0,84	0,63	0,85	0,89**	0,89	
Effective motor power	N	[kW]	$N_{\text{wirk}} = \sqrt{3} \times (U \times I_{\text{wirk}} \times \cos \varphi)$					(values at operating point – see selection tool)

60 Hz 3 x 380 V								
DESCRIPTION	Unit		HRP 3232	HRP 5040	HRP 5050	HRP 8050	HRP 10080	
Speed	n	[min ⁻¹]	3500	3500	3500	3500	3500	
max. power consumption								
with NH ₃	I _{max}	[A]	2,5	7,5	8,5	12,0	20,0	
with CO ₂	I _{max}	[A]	3,3	-	12,0	18,5	30,0	
With HFC, HFO, e.g. R134a	I _{max}	[A]	3,5	10	13,5	24,5**	33,0	
Motor power factor								
with NH ₃	Cos φ	[-]	0,93	0,86	0,91	0,91	0,93	
with CO ₂	Cos φ	[-]	0,93	-	0,91	0,91	0,93	
With HFC, HFO, e.g. R134a	Cos φ	[-]	0,93	0,86	0,91	0,93**	0,93	
Effective motor power	N	[kW]	$N_{\text{wirk}} = \sqrt{3} \times (U \times I_{\text{wirk}} \times \cos \varphi)$					(values at operating point – see selection tool)

60 Hz 3 x 575 V								
DESCRIPTION	Unit		HRP 3232	HRP 5040	HRP 5050	HRP 8050	HRP 10080	
Speed	n	[min ⁻¹]	3500	3500	3500	3500	-	
max. power consumption								
with NH ₃	I _{max}	[A]	1,7	4,7	5,5	8	-	
with CO ₂	I _{max}	[A]	2,2	-	8	12	-	
With HFC, HFO, e.g. R134a	I _{max}	[A]	2,3	5,5	9	-	-	
Motor power factor								
with NH ₃	Cos φ	[-]	0,88	0,86	0,87	0,90	-	
with CO ₂	Cos φ	[-]	0,92	-	0,90	0,90	-	
With HFC, HFO, e.g. R134a	Cos φ	[-]	0,93	0,86	0,91	-	-	
Effective motor power	N	[kW]	$N_{\text{wirk}} = \sqrt{3} \times (U \times I_{\text{wirk}} \times \cos \varphi)$ (values at operating point – see selection tool)					

* Measure the maximum current during commissioning and set the overload protection to this value, do not exceed I_{max} for the relevant refrigerant.

** The HRP8050-2 model requires a special motor for Freons and HFO, e.g. R134a with the dimensions and data of the motor for an HRP10080.

4.3 MATERIALS

Pump housing:	EN-GJS-400-18-LT
Stator:	steel / copper
Rotor:	steel/aluminium
Bearings:	PTFE
Shaft:	C 35+C
Motor can:	1.4301
Impellers:	stainless steel / AL-Bronze (only CO ₂)
Main bolts:	8.8
Counter flanges:	P355NL1 or C22.8
Bolts for counter flanges:	8.8
Gaskets	soft gasket asbestos free
Transformer oil	Fuchs Renolin Eltec
Painting system:	W 9.1 + W 9.2

W 9.1 + W 9.2 = 2 k epoxy finish according to DIN ISO 12944/5, RAL 7001

4.4 PRESSURE RANGE

	25 bar models	40 bar models	65 bar models	90 bar models
Design pressure (inside pump housing, motor can and stator housing)	25	40	65	90
Test pressure (with oil) [bar]	60	60	98	135
Allowable pressure range [bar]	25 (+50 / -10°C) 18,75 (-10 / -60°C)	40 (+50 / -10°C) 30 (-10 / -60°C)	65 (+50 / -10°C) 48,75 (-10 / -60°C)	90 (+50 / -10°C) 67,5 (-10 / -60°C)



For pressure testing with oil FUCHS Reniso Synth 68 is used.

The following table gives an overview of available standard and special pump types. Further pump types are under development.

Nennndruck und verfügbare Pumpen / Design pressure and available pumps							
Frequency	Design Press.	Refrigerant	pump type				
[Hz]	[bar]						
50 / 60	25	NH ₃ , CO ₂	HRP3232	HRP5040	HRP5050	HRP8050	HRP10080
50 / 60	25 40	Other HFC, HFO	Standard	Standard	Standard	Standard	Standard
		NH ₃ , CO ₂				Special	
	Other HFC, HFO	Standard		Standard			
	65	All refrigerants	Not available	Not available	Not available	Not available	
	90	Only CO ₂			Standard		Standard

4.5 DIMENSIONS

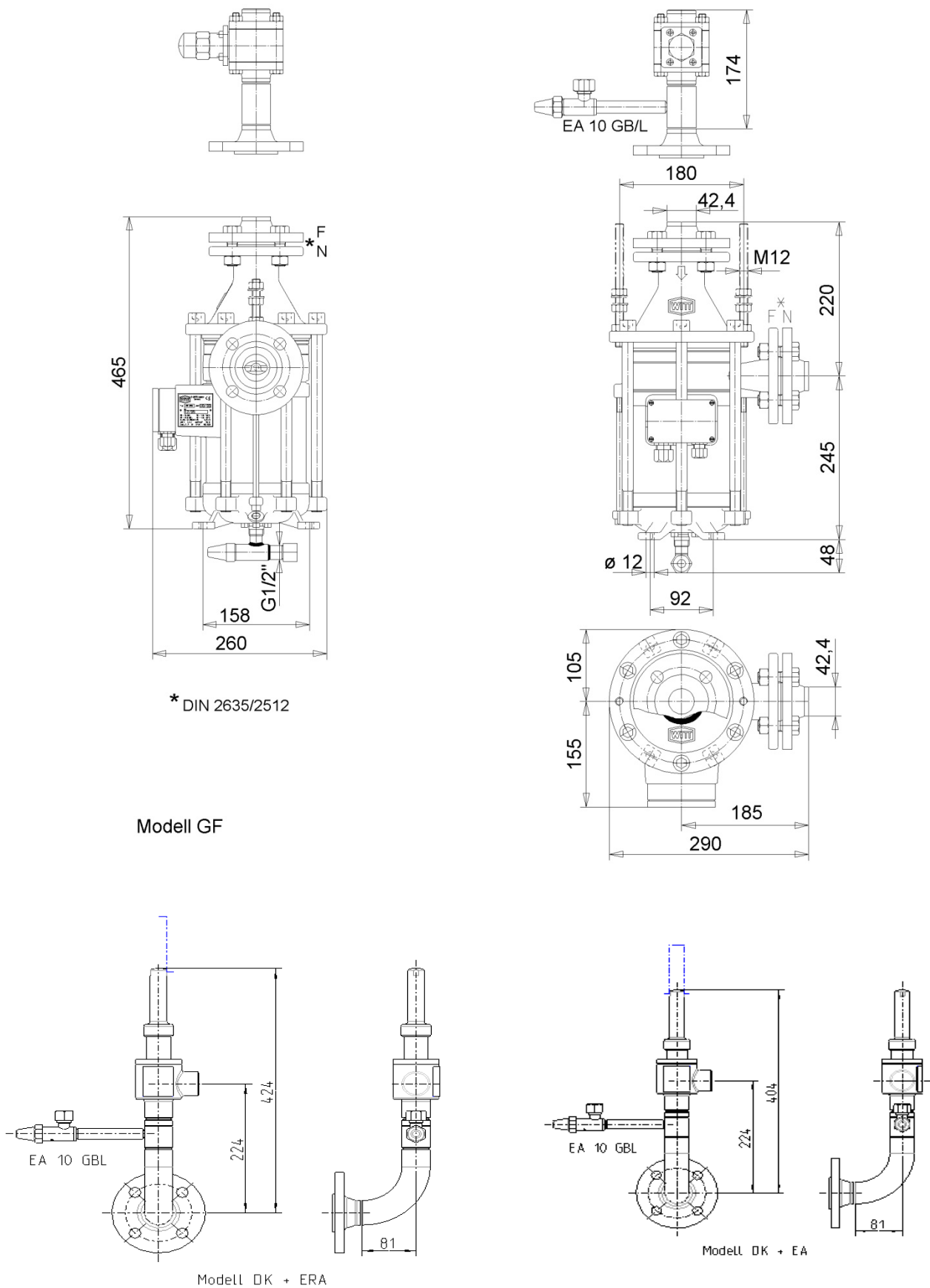

Fig. 1 HRP 3232

	HRP			
	5040	5050	8050	10080
L	540	520	555	725
B	260	310	310	355
H	283	349	351	362
a1	150	180	180	180
a2	228	234	255	302
a3	196	170	170	290
b1	105	133	133	133
b2	203	223	223	223
c	53	53	66	70
d1	60,3	60,3	88,9	114,3
d2	48,3	60,3	60,3	88,9
l1	155	155	178	212
m1	115	145	145	145
m2	168	204	206	217
m3	130	190	190	190

	HRP			
	5040	5050	8050	10080
f1	343	343	470	466
f2	346	343	343	---
f3	376	373	373	472
h1	138	138	179	179
h2	141	138	138	179

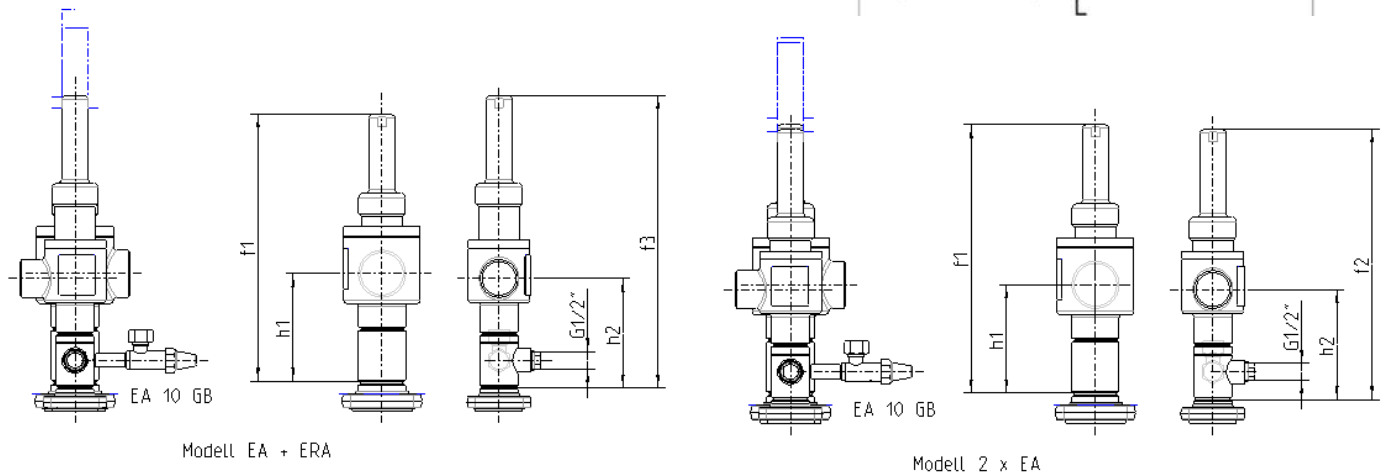
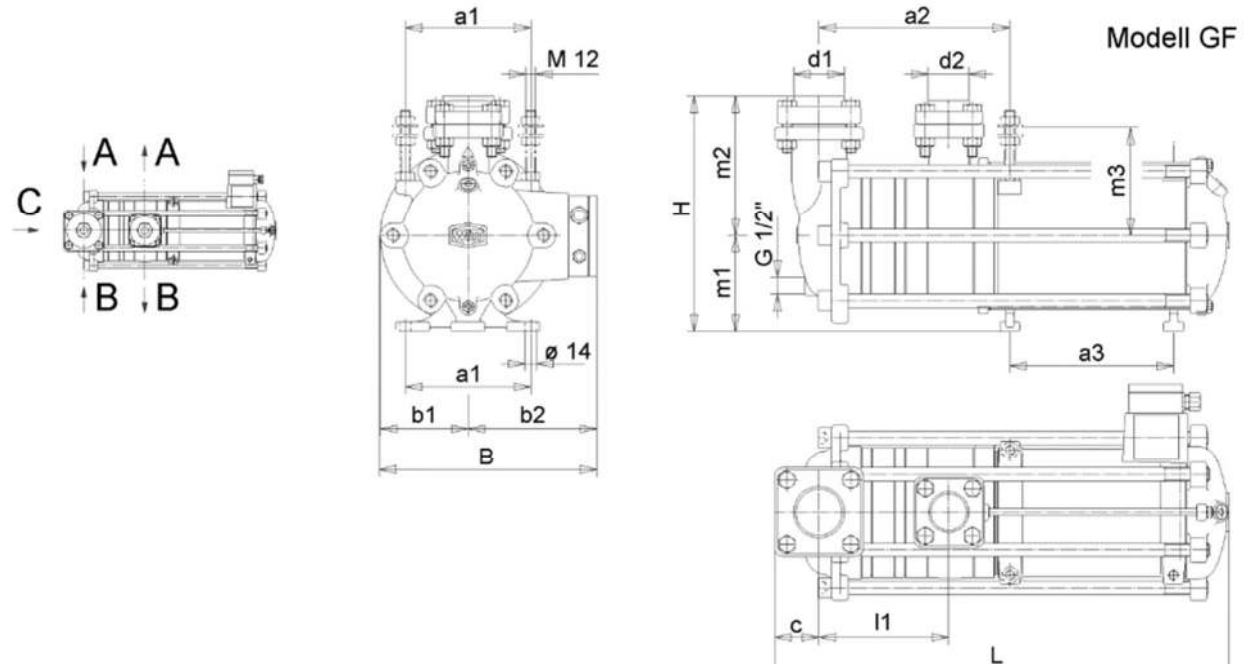

Fig. 2a HRP 5040/5050/8050/10080

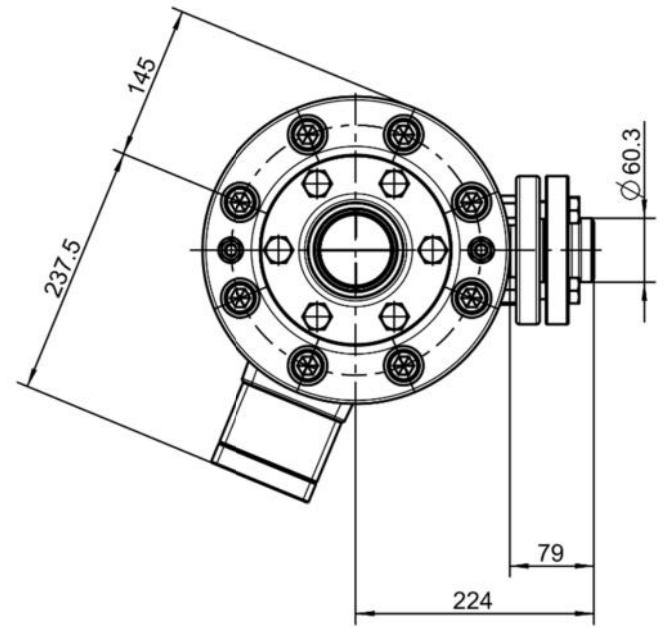
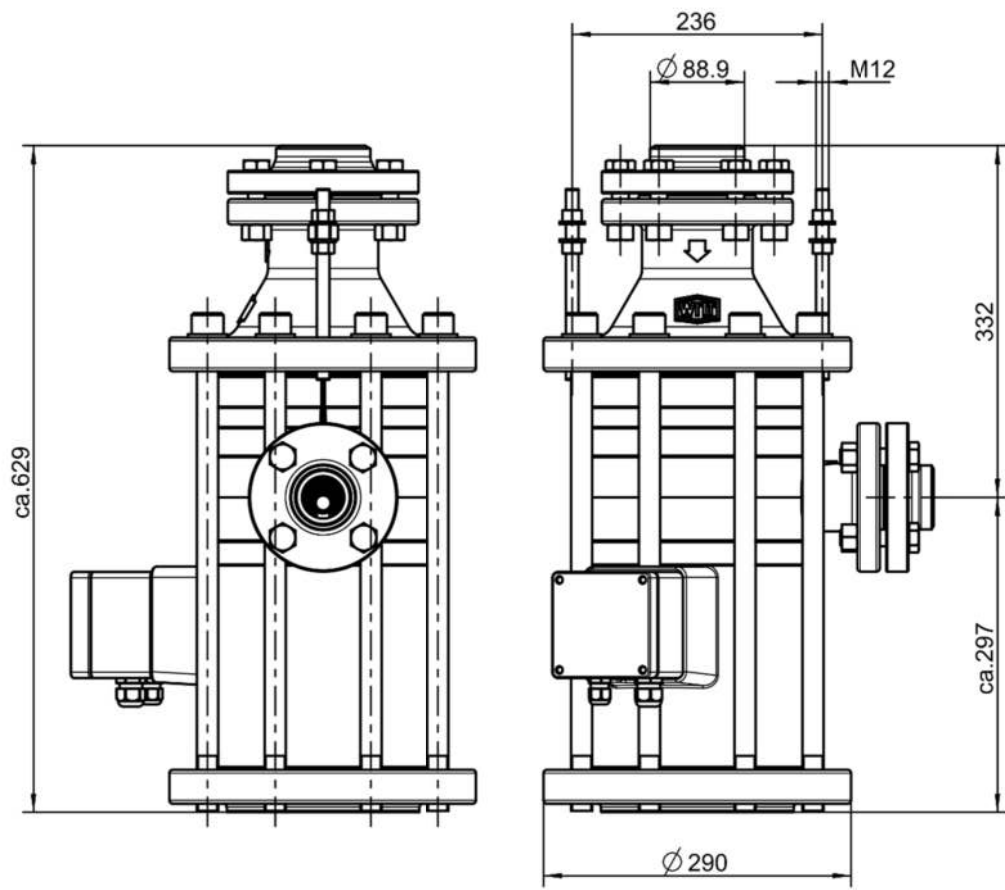

Fig. 2b: HRP 5050-90

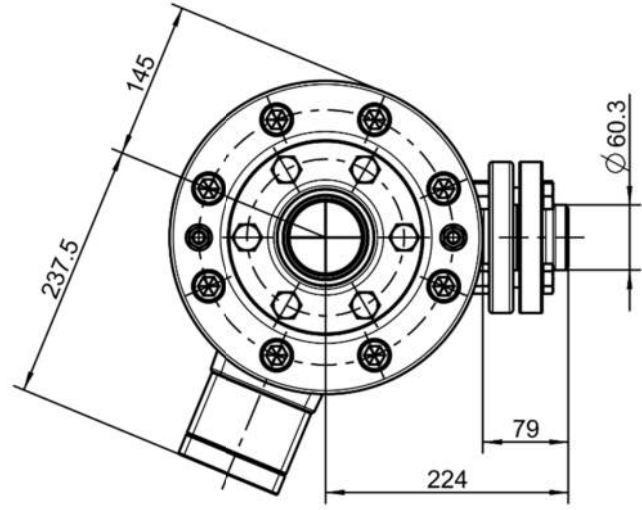
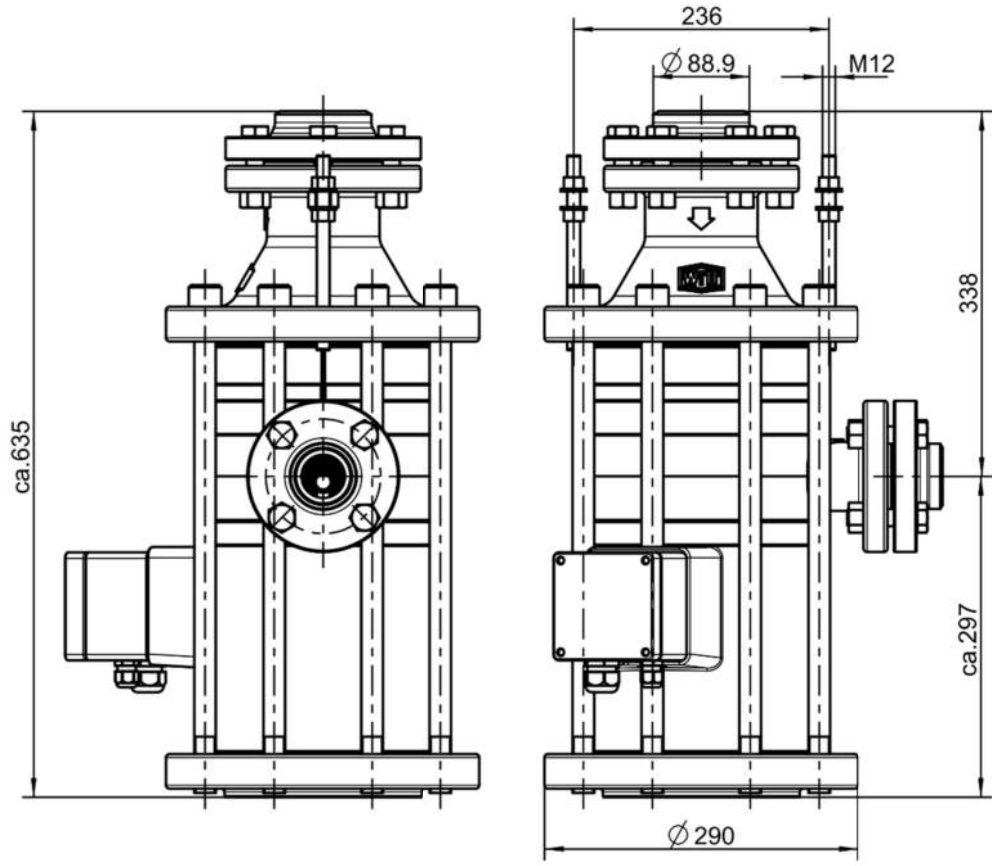

Fig. 2c: HRP 8050-90

4.6 SECTIONAL VIEWS

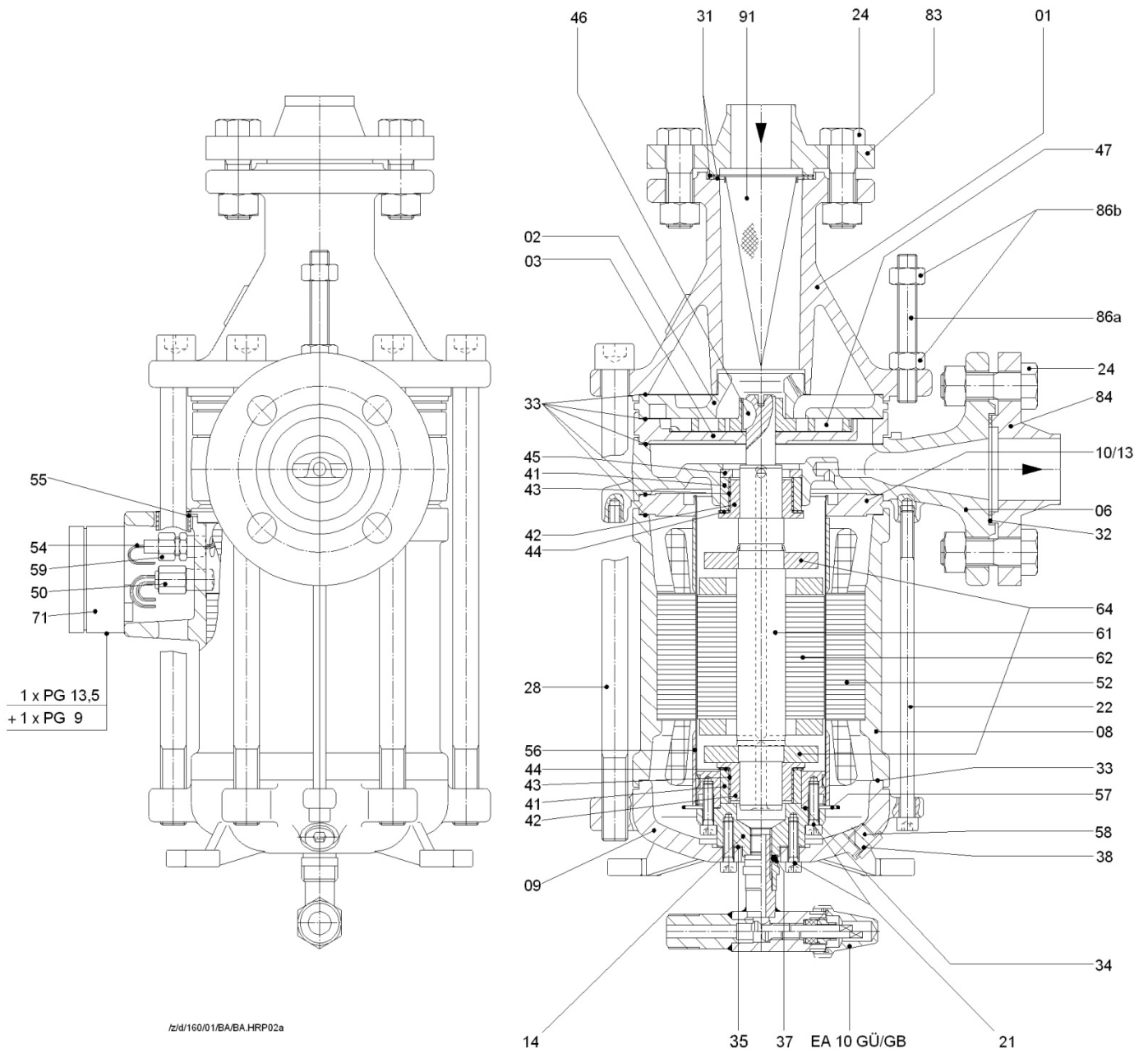

Fig. 3 a HRP 3232

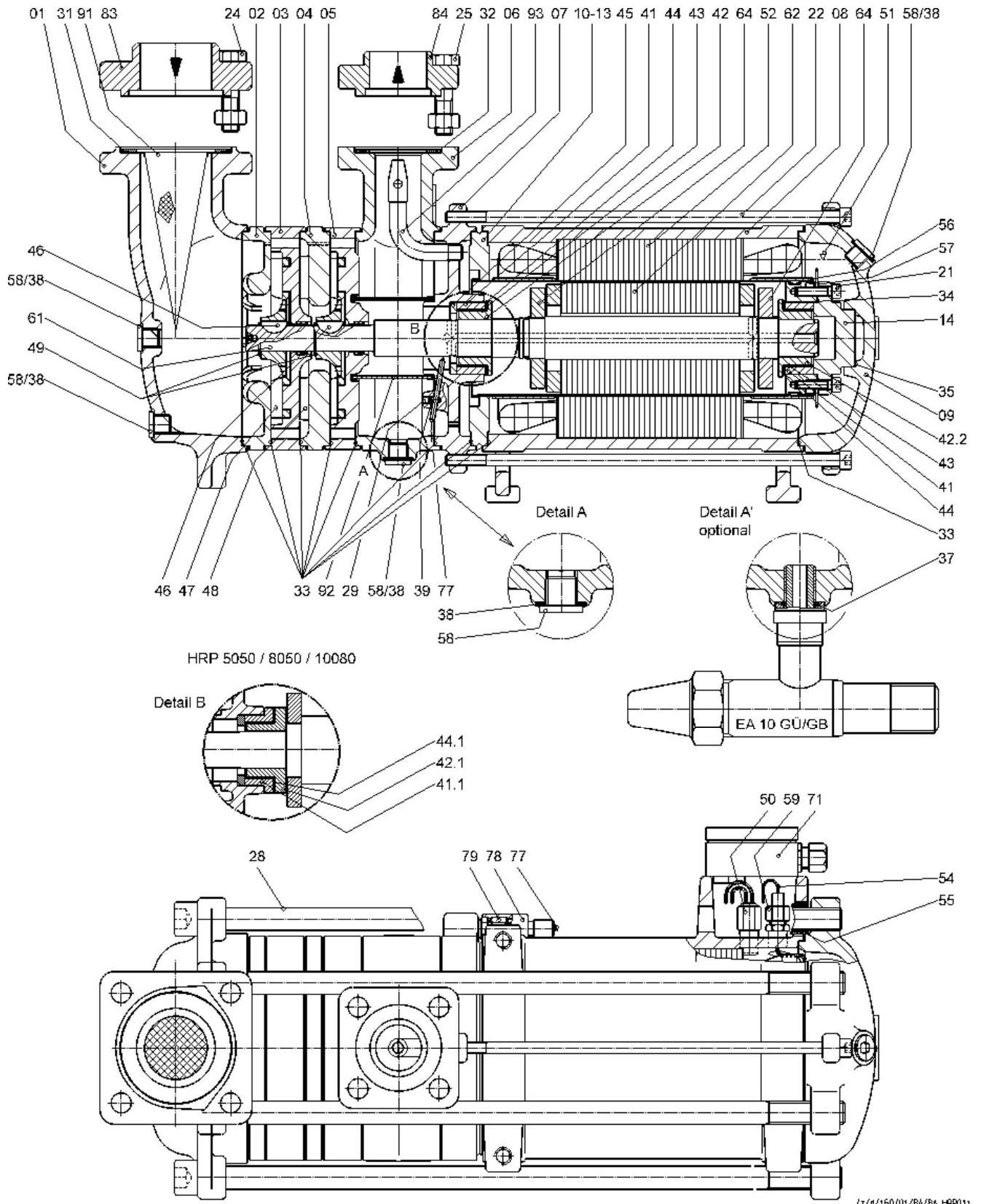

Fig. 3b HRP5040/HRP 5050/HRP 8050/HRP 10080

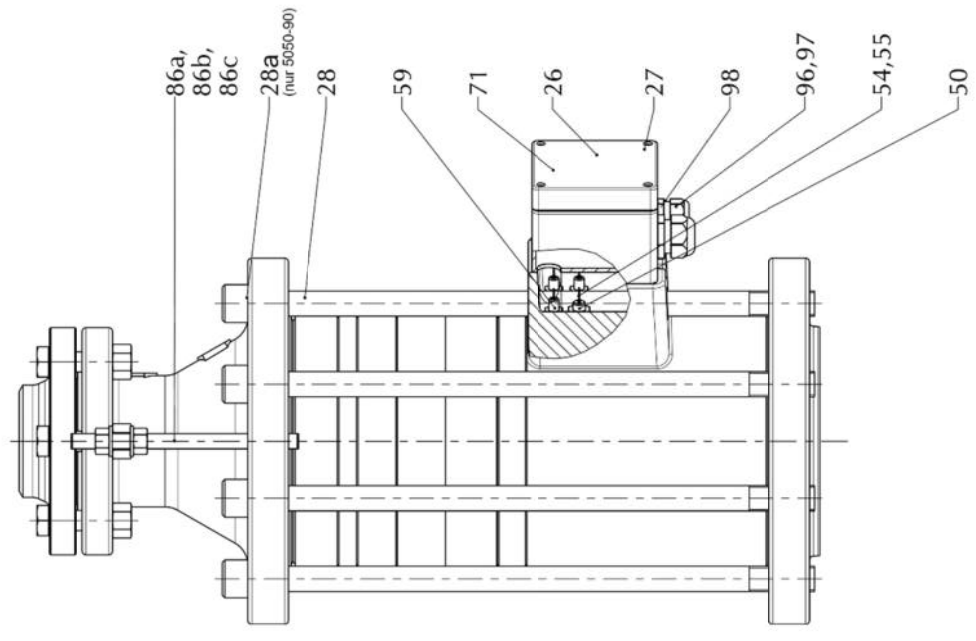
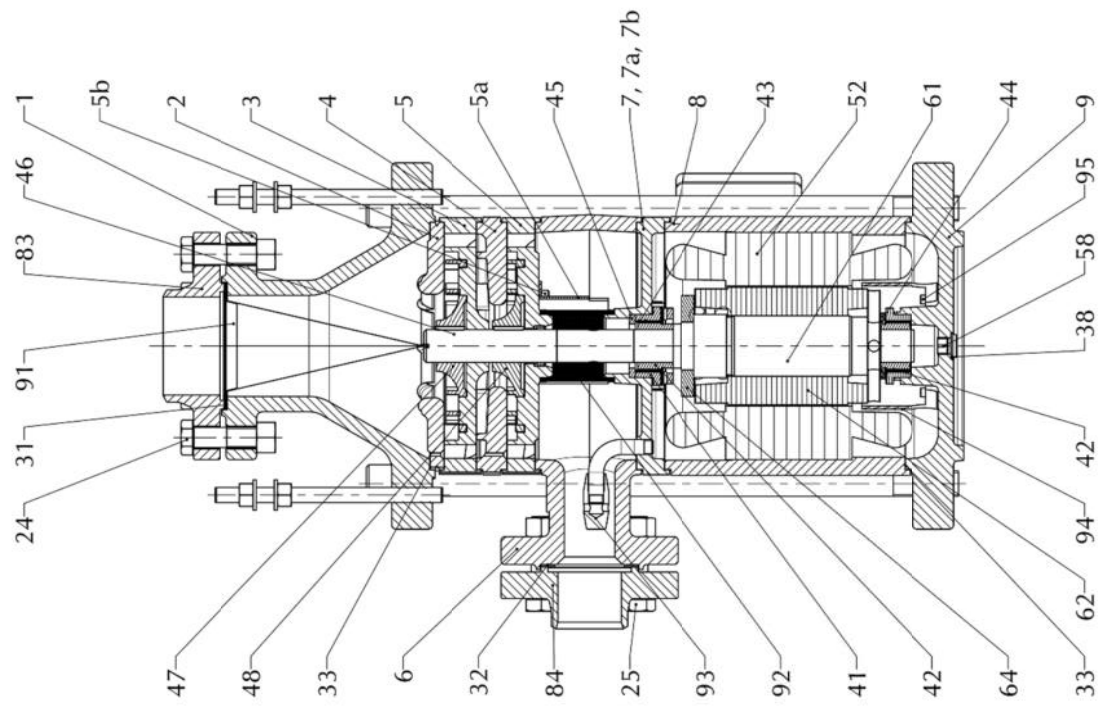

Fig. 3c HRP 5050-90 / HRP 8050-90

Parts list HRP 3232 and HRP 5040

	part No.	HRP 3232			HRP 5040		
		Dimension	Code - No.	Weight [g]	Dimension	Code - No.	Weight [g]
suction casing	01	DN 32	2162.000336	5960	DN 50	2162.000018	5380
suction intermediate piece	2	Ø150	2162.000309	1080	Ø150	2162.000026	1087
guide vane-intermediate piece 1	3		---	---	Ø150	2162.000030	1775
discharge intermediate piece	3	Ø150	2162.000311	1240		---	---
return intermediate piece	4		---	---	Ø150	2162.000036	2037
guide vane-intermediate piece 2	5		---	---	Ø150	2162.000031	1862
discharge casing	6	DN32	2162.000307	4020	DN40	2162.000022	2540
bearing casing	7		---	---	Ø150	A7	2080
stator casing	8	Ø150	A8	6660	Ø150	A8	8260
motor cover	9	Ø150	2162.000303	2720	Ø150	2162.000010	2980
can complete (parts 11-13)	10	Ø80	A10	1660	Ø80	A10	1740
bearing cover	14	Ø79	A10	541	Ø79	A10	497
socket head cap screw	21	M6 x 25	A10	7	M6 x 25	A10	7
socket head cap screw	22	M8 x 185	5112.BH61F4	74	M8 x 275	5112.BH61HM	109
hexagon head cap screw	24a	M16 x 55	5111.AHA1BI	107	M12 x 55	5111.AH81BI	60
hexagon nut	24b	M16	5151.AHA100	30	M12	5151.AH8100	15
hexagon head cap screw	25a		---	---	M12 x 55	5111.AH81BI	60
hexagon nut	25b		---	---	M12	5151.AH8100	15
torx screw for conn. box	26	4x30 TX20	5143.CLGAAT	3	4x30 TX20	5143.CLGAAT	3
earthing screw	27	M4 x 10	5112.AO31A9	1	M4 x 10	5112.AO31A9	1
long socket head cap screw	28	M16x280	5112.BHA2HR	454	M16x450	5112.BHA3MH	730
set screw	29		---	---	M6 x 10	A7	1
Gasket suction flange	31	51/65x1	5631.254110	3	55/77x1	5632.1BIC4I	4
Gasket discharge flange	32	51/65x2	5631.254K10	5	40/60 x2	5632.1B3BNK	6
gasket casing + intermediate pieces	33	138/149x0,3	E30	2	138/149x0,3	E30	2
Gasket can end	34	50/58x0,3	E30	1	50/58x0,3	E30	1
gasket motor cover	35	24/54x0,5	E30	1	30/40x0,5	E30	1
O-ring EA10 GÜ/GB	37	11x2,5	5642.ABAV01	1	---	---	---
metall gasket for 1/4" screw plug	38	14/20x1,5	E30	3	14/20x1,5	E30	3
set screw protection	39		---	---	Ø 5x5	A7	1
bearing sleeve	41	40/50x20	E41	110	40/50x20	E41	110
bearing bush	42	26/52x23	E41	132	26/52x23	E41	132
bearing strip	43	20/119x1	E42	5	20/119x1	E42	5
retaining disc	44	38,5/52x1	E42	2	38,5/52x1	E42	2
bearing disc	45	35/50x5	2162.000082	38	35/50x5	A7	38
key	46	5 x 7,5	5712.AGF001	4	5 x 7,5	5712.AGF001	4
radial impeller 1	47	Ø 111	2162.000313	175	Ø 111	2162.000040	300
radial impeller 2	48		---	---	Ø 111	2162.000041	273
circlip ring	49		---	---	Ø 18	5541.AAH120	1
temperature switch	50		---	---	70 °C	2162.000071	25
PTC resistor	50	90 °C	A8	25	90 °C	A8	25
transformer oil	51	1 Ltr	9832.100001	1425	1,0 Ltr	9832.100001	1425
stator	52	Ø 139	A8	4980	Ø 139	A8	9340
cable insulating plastic tube	54		A8	1		A8	1
cable protective tube	55		A8	1		A8	1
supporting sleeve	56	Ø 80 x 45	2162.000053	154	Ø 80 x 45	2162.000053	154
Supporting sleeve safety	57		2162.000085	6		2162.000085	6
screw plug 1/4"	58		5116.OG6210	13		5116.OG6210	13
cable inlet nipple	59		A8	27		A8	27
shaft	61		A60	-----		A60	-----
rotor	62	Ø 80	A60	3970	Ø 80	A60	3720
balancing disc	64		A60	260		A60	260
connecting box, compl.	71	98/64/38	2162.000075	243	98/64/38	2162.000075	243

backup fuse for PTC resistor	71a		2591.000101	1		2591.000101	1
sensor wire	77a		---	---		A7	1
sensor wire insulation	77b		---	---		A7	1
sensor connecting cover	78		---	---		A7	15
sensor inlet nipple	79		---	---		A7	27
counterflange suction side	83	DN32	E21	1720	DN50	E21	1194
counterflange discharge side	84	DN32	E22	1720	DN40	E22	713
threaded bar	86a	M12x180	5122.BFAJEZ	127	M12x180	5122.BFAJEZ	127
hexagon nut	86b	M12	5151.AH8100	15	M12	5151.AH8100	15
limpet washer	86c	Ø30/13x3	5161.K11100	12	Ø30/13x3	5161.K11100	12
suction strainer	91	Ø50x125	2196.000002	13	Ø50x125	2196.000002	13
bearing filter	92		---	---	Ø57x57	2162.000084	54
ejector	93		---	---		A7	80

HRP replacement assemblies and spare part sets

	HRP3232			HRP5040		
	Part	Article No.	Weight [g]	Part	Article No.	Weight [g]
bearing casing with parts: HRP 3232: 6;41; 45; E30; E42; 51; HRP 5040: 7;41; 45; E30; E42; 51, 77-79; 29; 39; 93	A7	2162.A00092	4938		2162.A00090	2330
stator with parts: HRP 3232: 08;52;54;55;59;71;E30;E42;51 HRP5040: 08;50;52;54;55;59;71;E30;E42;51	A8	2162.A00116	6360		2162.A00114	17650
motor can with parts: 10;41;14;21; E30; E42; 51	A10	2162.A00053	3161		2162.A00051	2354
Balanced shaft, rotor+impellers: 61-64; 42; 46; 47, 48, 49; E30; E42; 51			---	A60	2162.A00010	6453
shaft with rotor with parts: HRP 3232: 61-64; 42; 46; E30; E42; 51 HRP 5040: 61-64; 42; 46; 49; E30; E42; 51	A61	2162.A00118	5460		2162.A00112	5880
counterfl. suct. incl. mount.mat. 4x 24a, 4x 24b, 2x31, 83	E21	2162.000500	2212	E21	2162.000145	1600
counterfl. Deliv. incl. mount.mat 4x 25a, 4x25b, 1x32, 84	E22	2162.000500	2212	E22	2162.000144	967
set of gaskets: number x no. HRP 3232: 6x33, 1x34, 2x38 HRP 5040: 2x31; 1x32; 9x33 ; 1x34; 1x35; 4x38	E30	2162.000170	28		2162.000124	37
bearing sleeve (41) + -bush (42)	E41	2162.000126	241		2162.000126	241
bearing strips (2x43) + retaining discs (2x44)	E42	2162.000127	7		2162.000127	7

Parts list HRP5050

	part	HRP 5050			HRP 5050 CO ₂		
		dimension	code - no.	Weight [g]	dimension	code - no.	Weight [g]
suction casing	1	DN 50	2162.001002	7440	DN 50	2162.001002	7440
suction intermediate piece	2	Ø196	2162.001004	2420	Ø196	2162.001004	2420
guide vane-interm. piece 1	3	Ø196	2162.001007	3100	Ø196	2162.001013	3100
return intermediate piece	4	Ø196	2162.001006	5040	Ø196	2162.001006	5040
guide vane-interm. piece 2	5	Ø196	2162.001008	3470	Ø196	2162.001008	3470
guide plate for interm. piece 2	5a		2162.002041	126		2162.002041	126
.Screw for guide plate	5b	M6 x 10	5112.BC51A9	5	M6 x 10	5112.BC51A9	5
discharge casing	6	DN 50	2162.000024	4080	DN 50	2162.000024	4080
bearing casing	7	Ø196	A7	2880	Ø196	A7- CO ₂	2880
stator casing	8	Ø196	A8	10550	Ø196	A8- CO ₂	10550
motor cover	9	Ø196	2162.000012	3640	Ø196	2162.000012	3640
can compl. (incl. parts 11-13)	10	Ø95	A10	3055	Ø95	A10- CO ₂	3055
bearing cover	14	Ø79	A10	497	Ø79	A10- CO ₂	497
socket head cap screw	21	M6 x 25	A10	7	M6 x 25	A10- CO ₂	7
socket head cap screw	22	M8 x 245	5112.BH61GS	98	M8 x 245	5112.BH61GS	98
hexagon head cap screw	24a	M16 x 65	5111.AH81BI	126	M16 x 65	5111.AH81BI	126
hexagon nut	24b	M16	5151AH8100	30	M16	5151AH8100	30
hexagon head cap screw	25a	M12 x 55	5111.AH81BI	60	M12 x 55	5111.AH81BI	60
hexagon nut	25b	M12	5151.AH8100	15	M12	5151.AH8100	15
torx screw for conn. box	26	4x30 TX20	5143.CLGAAT	3	4x30 TX20	5143.CLGAAT	3
earthing screw	27	M4 x 10	5112.AO31A9	1	M4 x 10	5112.AO31A9	1
long socket head cap screw	28	M16x450	5112.BHA3MH	730	M16x450	5112.BHA3MH	730
set screw	29	M6 x 10	A7	1	M6 x 10	A7- CO ₂	1
joint suction flange	31	55/77x2	5632.1BIC4I	4	55/77x2	5632.1BIC4I	4
joint discharge flange	32	55/77x2	5632.1BIC4K	8	55/77x2	5632.1BIC4K	8
joint casing + interm. pieces	33	180/195x0,3	E30	3	180/195x0,3	E30	3
joint can end	34	50/58x0,3	E30	1	50/58x0,3	E30	1
joint motor cover	35	30/40x0,5	E30	1	30/40x0,5	E30	1
joint 1/4" screw plug	38	14/20x1,5	E30	3	14/20x1,5	E30	3
set screw protection	39	Ø 5x5	A7	1	Ø 5x5	A7- CO ₂	1
bearing sleeve (motor side)	41	40/50x20	E41.1	108	40/50x20	E41.1 - CO ₂	108
bearing sleeve II (pump side)	41.1	40/60x20	E41.1	147	---	---	---
bearing sleeve III (pump side)	41.1- CO ₂	---	---	---	40/70x20	E41.1 - CO ₂	147
bearing bush II (pump side)	42.1	26/60x28	E41.1	237	---	---	---
bearing bush II.3 (pump side)	42.1- CO ₂	---	---	---	26/60x28	E41.1 - CO ₂	218
bearing bush I.2 (motor side)	42.2	26/52x23	E41.1	124	26/52x23	E41.1 - CO ₂	124
bearing strip	43	20/119x1	E42.1	5	20/119x1	E42.1- CO ₂	5
retaining disc (motor side)	44	38,5/52x1	E42.1	2	38,5/52x1	E42.1- CO ₂	2
retaining disc II (pump side)	44.1	39,5/60x1	E42.1	4	---	---	---
retaining disc IV (pump side)	44.1- CO ₂	---	---	---	41,5/70x3	E42.1- CO ₂	6
bearing disc	45	35/50x5	A7	38	35/50x5	A7- CO ₂	38
key	46	6 x 10	5712.AHH001	9	6 x 10	5712.AHH001	9
radial impeller 1	47	Ø 136	2162.001009	475	Ø 136	2162.001011	475
radial impeller 2	48	Ø 136	2162.001010	460	Ø 136	2162.001012	460
circlip ring	49	Ø 26	5541.AAP120	2	---	---	---
PTC resistor wire outlet	50	90 °C	A8	25	90 °C	A8- CO ₂	25
transformer oil, 2 L required	51	1,0 L	9832.100001	1425	1,0 L	9832.100001	1425
stator	52	Ø 180	A8	15000	Ø 180	A8- CO ₂	15000
cable insulating plastic tube	54		A8	1		A8- CO ₂	1
cable protective tube	55		A8	1		A8- CO ₂	1
supporting sleeve	56	Ø101,6 x 47	2162.000054	298	Ø101,6 x 47	2162.000054	298
supporting sleeve safety	57		2162.000085	6		2162.000085	6
screw plug 1/4"	58		5116.OG6210	13		5116.OG6210	13
cable inlet nipple	59		A8	27		A8- CO ₂	27
shaft	61		A60	---		A60- CO ₂	---
rotor	62	Ø 95	A60	---	Ø 95	A60- CO ₂	---
balancing disc	64		A60	---		A60- CO ₂	---
connecting box, compl.	71	98/64/38	2162.000075	243	98/64/38	2162.000075	243
backup fuse for PTC resistor	71a		2591.000101	1		2591.000101	1

sensor wire	77a		A7	1		A7- CO ₂	1
sensor wire insulation	77b		A7	1		A7- CO ₂	1
sensor connecting cover	78		A7	15		A7- CO ₂	15
sensor inlet nipple	79		A7	27		A7- CO ₂	27
counterflange suction side	83	DN50	E21	1194	DN50	E21	1194
counterflange discharge side	84	DN50	E22	1194	DN50	E22	1194
threaded bar	86a	M12x180	5122.BFAJEZ	127	M12x180	5122.BFAJEZ	127
hexagon nut	86b	M12	5151.AH8100	15	M12	5151.AH8100	15
limpet washer	86c	Ø30/13x3	5161.K11100	12	Ø30/13x3	5161.K11100	12
Conical filter, suction side	91	Ø50x125	2196.000002	13	Ø50x125	2196.000002	13
bearing filter	92	Ø57x57	2162.000084	54	Ø57x57	2162.000213	54
ejector	93		A7	80		A7- CO ₂	80

complete HRP-replacement assemblies and spare part sets

	HRP 5050				HRP 5050 CO ₂		
	Teil		Artikelnummer	Gewicht [g]		Artikelnummer	Gewicht [g]
bearing casing and shaft with rotor A7 + A60	U1	until 3/2003	2162.A00093	12000	---	---	---
stator with parts: 08, 50, 51, 52, 54, 55, 59, 71, E30, E42	A8		2162.A00117	25520	---	---	---
Motor can with parts: 10, 14, 21, 41, 51, E30, E42	A10		2162.A00050	3670	---	---	--
bearing sleeve + bearing bush, parts: 2x41 +2x42	E41		2162.000126	241	----	---	---
Bearing strip + retaining disks: 2x43 + 2x44	E42		2162.000127	7	---	---	---
bearing casing with parts: 07, 29, 39, 41.1, 45, 51, 77-79, 93, E30, E42.1	A7	since 04/03	2162.A00088	3200	---	---	---
stator with parts 08, 50, 51, 52, 54, 55, 59, 71, E30, E42.1	A8	since 04/03	2162.A00120	25520	---	---	---
Motor can with parts: 10, 14, 21, 41.1, 51, E30, E42.1	A10	since 04/03	2162.A00054	3670	---	---	---
shaft with rotor with parts: 42, 42.1, 46; 49, 51, 61-64, E30, E42.1	A61	since 04/03	2162.A00009	8750	---	---	---
Balanced shaft, rotor + impellers: 42.2, 42.1, 46; 47, 48, 49, 51, 61-64, E30, E42.1	A60	since 01/10	2162.A00011	9685	A60- CO ₂	2162.A00012	9685
bearing sleeve + bearing bush 1x41.1 + 1x41 + 1x42.1 + 1x42.2	E41.1	since 04/03	2162.000200	241	E41.1 CO ₂	2162.000230	241
bearing strips + retaining disks 2x43 + 1x44.1 + 1x44	E42.1	since 04/03	2162.000202	7	E42.1	2162.000202	7
bearing casing with parts: 07, 29, 39, 41.1-CO ₂ , 45, 51, 77-79, 93, E30, E42.1- CO ₂		since 01/12	---	---	A7 - CO ₂	2162.A00096	5150

stator with parts 08, 50, 51, 52, 54, 55, 59, 71, E30, E42.1- CO ₂		since 01/12	---	---	A8- CO ₂	2162.A00124	25520
Motor can with parts: 10, 14, 21, 41, 51, E30, E42.1- CO ₂		since 01/12	---	---	A10- CO ₂	2162.A00057	3670
bearing sleeve + bearing bush 1x41.1 - CO ₂ + 1x41 + 1x42.1- CO ₂ + 1x42.2		since 01/12	---	---	E41.1- CO ₂	2162.000233	241
bearing strips + retaining disks: 2x43 + 1x44.1-CO ₂ + 1x44		since 01/12	---	---	E42.1- CO ₂	2162.000232	7
set of gaskets: number x no. 2x31; 1x32; 9x33 ; 1x34; 1x35; 3x38	E30		2162.001200	33	E30	2162.001200	33
..Counterflange incl. mount. mat. 4 x 24a, 4 x 24b, 2 x 31, 83	E21		2162.000145	1600	E21	2162.000145	1600
..Counterflange incl. mount. mat. 4 x 25a, 4 x 25b, 1 x 32, 84	E22		2162.000145	1600	E22	2162.000145	1600
Blindflange suction side <i>Inkl. Befestigungsmaterial</i>	---		2162.009100	2650	---	2162.009100	2650
Blindflange pressure side <i>including mounting material</i>	---		2162.009100	2650	---	2162.009100	2650

Parts list HRP8050

	part	HRP 8050			HRP8050 CO ₂		
		dimension	code - no.	Weight [g]	dimension	code - no.	Weight [g]
suction casing	1	DN 80	2162.009015	9040	DN 80	2162.009015	9040
suction intermediate piece	2	Ø196	2162.000028	2276	Ø196	2162.000028	2276
guide vane-interm. piece 1	3	Ø196	2162.000033	3764	Ø196	2162.000033	3764
return intermediate piece	4	Ø196	2162.000038	3684	Ø196	2162.000038	3684
guide vane-interm. piece 2	5	Ø196	2162.009016	3854	Ø196	2162.009016	3854
guide plate for interm. piece 2	5a		2162.002041	126		2162.002041	126
Screw for guide plate	5b	M6 x 10	5112.BC51A9	5	M6 x 10	5112.BC51A9	5
discharge casing	6	DN 50	2162.000024	4080	DN 50	2162.000024	4080
bearing casing	7	Ø196	A7	2880	Ø196	A7- CO ₂	2880
stator casing	8	Ø196	A8	10550	Ø196	A8- CO ₂	10550
motor cover	9	Ø196	2162.000012	3640	Ø196	2162.000012	3640
can compl. (incl. parts 11-13)	10	Ø95	A10	3055	Ø95	A10- CO ₂	3055
bearing cover	14	Ø79	A10	497	Ø79	A10- CO ₂	497
socket head cap screw	21	M6 x 25	A10	7	M6 x 25	A10- CO ₂	7
socket head cap screw	22	M8 x 245	5112.BH61GS	98	M8 x 245	5112.BH61GS	98
hexagon head cap screw	24a	M16 x 65	5111.AHA1BS	126	M16 x 65	5111.AHA1BS	126
hexagon nut	24b	M16	5151AHA100	30	M16	5151AHA100	30
hexagon head cap screw	25a	M12 x 55	5111.AH81BI	60	M12 x 55	5111.AH81BI	60
hexagon nut	25b	M12	5151.AH8100	15	M12	5151.AH8100	15
torx screw for conn. box	26	4x30 TX20	5143.CLGAAT	3	4x30 TX20	5143.CLGAAT	3
earthing screw	27	M4 x 10	5112.AO31A9	1	M4 x 10	5112.AO31A9	1
long socket head cap screw	28	M16x450	5112.BHA3MH	730	M16x450	5112.BHA3MH	730
set screw	29	M6 x 10	A7	1	M6 x 10	A7- CO ₂	1
joint suction flange	31	77/100 x1	5632.1C4CRI	6	77/100 x1	5632.1C4CRI	6
joint discharge flange	32	55/77x2	5632.1BIC4K	8	55/77x2	5632.1BIC4K	8
joint casing + interm. pieces	33	180/195x0,3	E30	3	180/195x0,3	E30	3
joint can end	34	50/58x0,3	E30	1	50/58x0,3	E30	1
joint motor cover	35	30/40x0,5	E30	1	30/40x0,5	E30	1
joint 1/4" screw plug	38	14/20x1,5	E30	3	14/20x1,5	E30	3
set screw protection	39	Ø 5x5	A7	1	Ø 5x5	A7- CO ₂	1
bearing sleeve I.2 (motor side)	41	40/50x20	E41.1	110	40/50x20	E41.1 – CO ₂	110
bearing sleeve II.2 (pump side)	41.1	40/60x20	E41.1	150	---	---	---
bearing sleeve III (pump side)	41.1-CO ₂	---	---	---	40/70x20	E41.1 – CO ₂	147
bearing bush II (pump side)	42.1	26/60x28	E41.1	240	---	---	---
bearing bush II.3 (pump side)	42.1-CO ₂	---	---	---	26/60x28	E41.1 – CO ₂	220
Bearing bush I.2 (motor side)	42.2	26/52x23	E41.1	125	26/52x23	E41.1 – CO ₂	125
bearing strip	43	20/119x1	E42.1	5	20/119x1	E42.1- CO ₂	5
retaining disc	44	38,5/52x1	E42.1	2	38,5/52x1	E42.1- CO ₂	2
retaining disc II	44.1	39,5/60x1	E42.1	4	---	---	---
retaining disc II	44.1-CO ₂	---	---	---	41,5/70x3	E42.1- CO ₂	6
bearing disc	45	35/50x5	A7	38	35/50x5	A7- CO ₂	38
key	46	6 x 10	5712.AHH001	9	6 x 10	5712.AHH001	9
radial impeller 1	47	Ø 136	2162.000043	557	Ø 136	2162.009000	558
radial impeller 2	48	Ø 136	2162.000044	513	Ø 136	2162.009001	514
circlip ring	49	Ø 26	5541.AAP120	2	---	---	---
PTC resistor wire outlet	50	90 °C	A8	---	90 °C	A8- CO ₂	---
transformer oil, (2 L required)	51	1,0 L	9832.100001	1425	1,0 L	9832.100001	1425
stator	52	Ø 180	A8	15000	Ø 180	A8- CO ₂	15000
cable insulating plastic tube	54	---	A8	1	---	A8- CO ₂	1
cable protective tube	55	---	A8	1	---	A8- CO ₂	1
supporting sleeve	56	Ø101,6 x 47	2162.000054	298	Ø101,6 x 47	2162.000054	298
supporting sleeve safety	57	---	2162.000085	6	---	2162.000085	6
screw plug 1/4"	58	---	5116.OG6210	13	---	5116.OG6210	13
cable inlet nipple	59	---	A8	---	---	A8- CO ₂	---
shaft	61	---	A60	---	---	A60 – CO ₂	---
rotor	62	Ø 95	A60	3700	Ø 95	A60 – CO ₂	3700
balancing disc	64		A60	260		A60 – CO ₂	260
connecting box, compl.	71	98/64/38	2162.000075	243	98/64/38	2162.000075	243
backup fuse for PTC resistor	71a	---	2591.000101	1	---	2591.000101	1

<i>sensor wire</i>	77a	---	A7	1	---	A7- CO ₂	1
<i>sensor wire insulation</i>	77b	---	A7	1	---	A7- CO ₂	1
<i>sensor connecting cover</i>	78	---	A7	15	---	A7- CO ₂	15
<i>sensor inlet nipple</i>	79	---	A7	27	---	A7- CO ₂	27
<i>counterflange suction side</i>	83	DN80	E21	1625	DN80	E21	1625
<i>counterflange discharge side</i>	84	DN50	E22	1194	DN50	E22	1194
<i>threaded bar</i>	86a	M12x180	5122.BFAJEZ	127	M12x180	5122.BFAJEZ	127
<i>hexagon nut</i>	86b	M12	5151.AH8100	15	M12	5151.AH8100	15
<i>limpet washer</i>	86c	Ø30/13x3	5161.K11100	12	Ø30/13x3	5161.K11100	12
<i>Conical filter, suction side</i>	91	Ø83/76x160	2196.000004	17	Ø83/76x160	2196.000004	17
<i>bearing filter</i>	92	Ø57x57	2162.000084	54	Ø57x57	2162.000213	54
<i>ejector</i>	93	---	A7	80	---	A7- CO ₂	80

complete HRP-replacement assemblies and spare part sets

	HRP 8050				HRP 8050 CO ₂		
	Teil		Artikelnummer	Gewicht [g]	Teil	Artikelnummer	Gewicht [g]
bearing casing and shaft with rotor A7 + A60	U1	until 03/2003	2162.A00095	12000	---	---	---
stator with parts: 08, 50, 51, 52, 54, 55, 59, 71, E30, E42	A8		2162.A00115	25520	---	---	---
can with parts: 10, 14, 21, 41, 51, E30, E42	A10		2162.A00052	3670	---	---	--
bearing sleeve + bearing bush 2x41 +2x42.2	E41		2162.000126	241	----	---	---
bearing strip + retaining disk: 2x43 + 2x44	E42		2162.000127	7	---	---	---
bearing casing with parts: 07, 29, 39, 41.1, 45, 51, 77-79, 93, E30, E42.1	A7	since 04/03	2162.A00091	3200	---	---	---
stator with parts: 08, 50, 51, 52, 54, 55, 59, 71, E30, E42.1	A8	since 04/03	2162.A00121	25520	---	---	---
can with parts: 10, 14, 21, 41.1, 51, E30, E42.1	A10	since 04/03	2162.A00056	3670	---	---	---
shaft with rotor with parts: 42.1, 42.2, 46; 49, 51, 61-64, E30, E42.1	A61	since 04/03	2162.A000113	7130	---	---	---
Balanced shaft, rotor + impellers: 42.1-CO ₂ , 42.2, 46; 47, 48, 49, 51, 61-64, E30, E42.1	A60	since 01/10	2162.A00013	8200	A60- CO ₂	2162.A00014	8202
bearing sleeve + bearing bush: 1x41.1 + 1x41 + 1x42.1 + 1x42.2	E41.1	since 04/03	2162.000200	241	---	---	---
bearing strip + retaining disk: 2x43 + 1x44.1 + 1x44	E42.1	since 04/03	2162.000202	7	---	---	---
bearing casing with parts: 07, 29, 39, 41.1-CO ₂ , 45, 51, 77-79, 93, E30, E42.1-CO ₂	---	since 01/12	---	---	A7- CO ₂	2162.A00097	5150
stator with parts: 08, 50, 51, 52, 54, 55, 59, 71, E30, E42.1- CO ₂	---	since 01/12	---	---	A8- CO ₂	2162:A00125	25520
can with parts: 10, 14, 21, 41, 51, E30, E42.1- CO ₂	---	since 01/12	---	---	A10- CO ₂	2162.A00058	3670
bearing sleeve + bearing bush: 1x41.1-CO ₂ + 1x41 + 1x42.1-CO ₂ + 1x42.2	---	since 01/12	---	---	E41.1-CO ₂	2162.000233	241
bearing strip + retaining disk: 2x43 + 1x44.1-CO ₂ + 1x44	---	since 01/12	---	---	E42.1- CO ₂	2162.000232	7
set of joints: number x no. : 2x31; 1x32; 9x33 ; 1x34; 1x35; 3x38	E30		2162.000125	33	E30	2162.000125	33

..Counterflange incl. mount. mat. 4 x 24a, 4 x 24b, 2 x 31, 83,	E21		2162.000146	2531	E21	2162.000146	2531
..Counterflange incl. mount. mat. 4 x 25a, 4 x 25b, 1 x 32, 84	E22		2162.000145	1600	E22	2162.000145	1600
Blindflange suction side <i>Inkl. Befestigungsmaterial</i>	---		2162.002210	3500	---	2162.002210	3500
Blindflange pressure side <i>including mounting material</i>	---		2162.009100	2650	---	2162.009100	2650

Parts list HRP8050-2

		HRP 8050-2		
	part	dimension	code - no.	Weight [g]
suction casing	1	DN 80	2162.000178	9040
suction intermediate piece	2	Ø196	2162.000028	2276
guide vane-interm. piece 1	3	Ø196	2162.000033	3764
return intermediate piece	4	Ø196	2162.000038	3684
guide vane-interm. piece 2	5	Ø196	2162.000034	3854
guide plate for interm. piece 2	5a		2162.002041	126
.Screw for guide plate	5b	M6 x 10	5112.BC51A9	5
discharge casing	6	DN 50	2162.000024	4080
bearing casing	7	Ø196	A7-CO2	2880
stator casing	8	Ø196	A8	10550
motor cover	9	Ø196	2162.000012	3640
can compl. (incl. parts 11-13)	10	Ø95	A10	3055
bearing cover	14	Ø79	A10	497
socket head cap screw	21	M6 x 25	A10	7
socket head cap screw	22	M8 x 245	5112.BH61GS	98
hexagon head cap screw	24a	M16 x 65	5111.AHA1BS	126
hexagon nut	24b	M16	5151.AHA100	30
hexagon head cap screw	25a	M12 x 55	5111.AH81BI	60
hexagon nut	25b	M12	5151.AH8100	15
torx screw for conn. box	26	4x30 TX20	5143.CLGAAT	3
earthing screw	27	M4 x 10	5112.AO31A9	1
long socket head cap screw	28a	M16x285	5112.BHA2HW	462
Screw adaptor	28b	M16	2162.002039	350
long socket head cap screw	28c	M16x220	5112.BHA1G3	320
set screw	29	M6 x 10	A7-CO2	1
joint suction flange	31	77/100 x1	5632.1C4CRI	6
joint discharge flange	32	55/77x2	5632.1BIC4K	8
joint casing + interm. pieces	33	180/195x0,3	E30	3
joint can end	34	50/58x0,3	E30	1
joint motor cover	35	30/40x0,5	E30	1
joint 1/4" screw plug	38	14/20x1,5	E30	3
set screw protection	39	Ø 5x5	A7-CO2	1
Bearing sleeve I.2 (motor side)	41	40/50x20	E41.1-CO2	110
bearing sleeve III (pump side)	41.1-CO ₂	40/70x20	E41.1-CO2	147
bearing bush II.3 (pump side)	42.1	26/60x28	E41.1-CO2	220
bearing bush I.2 (motor side)	42.2	26/52x23	E41.1-CO2	125
bearing strip	43	20/119x1	E42.1-CO2	5
retaining disc (motor side)	44	38,5/52x1	E42.1-CO2	2
retaining disc IV (pump side)	44.1-CO ₂	41,5/70x3	E42.1-CO2	6
bearing disc	45	35/50x5	A7-CO2	38
key	46	6 x 10	5712.AHH001	9
radial impeller 1	47	Ø 136	2162.000043	557
radial impeller 2	48	Ø 136	2162.000044	513
circlip ring	49	Ø 26	5541.AAP120	2
PTC resistor wire outlet	50	90 °C	A8	---
transformer oil, (2 L required)	51	1,0 L	9832.100001	1425
stator	52	Ø 180	A8	15000
cable insulating plastic tube	54		A8	1
cable protective tube	55		A8	1
supporting sleeve	56	Ø101,6 x 47	2162.000054	298
supporting sleeve safety	57		2162.000085	6
screw plug 1/4"	58		5116.0G6210	13
cable inlet nipple	59		A8	---
shaft	61		A60	---
rotor	62	Ø 95	A60	3700
balancing disc	64		A60	260
connecting box, compl.	71	98/64/38	2162.000075	243
backup fuse for PTC resistor	71a		2591.000101	1
sensor wire	77a		A7-CO2	1
sensor wire insulation	77b		A7-CO2	1
sensor connecting cover	78		A7-CO2	15
sensor inlet nipple	79		A7-CO2	27
counterflange suction side	83	DN80	E21	1625
counterflange discharge side	84	DN50	E22	1194
threaded bar	86a	M12x180	5122.BFAJEZ	127
hexagon nut	86b	M12	5151.AH8100	15
limpet washer	86c	Ø30/13x3	5161.K11100	12
Conical filter, suction side	91	Ø83/76x160	2196.000004	17
bearing filter	92	Ø57x57	2162.000084	54
ejector	93		A7-CO2	80

complete HRP-replacement assemblies and spare part sets

	HRP 8050-2			
	Part		Article No.	Weight [g]
bearing casing with parts: 07, 29, 39, 41.1, 45, 51, 77-79, 93, E30, E42.1	A7-CO ₂		2162.A00097	5150
stator with parts: 08, 50, 51, 52, 54, 55, 59, 71, E30, E42.1	A8		2162.A00127	25520
can with parts: 10, 14, 21, 41.1, 51, E30, E42.1	A10		2162.A00060	3670
Balanced shaft, rotor + impellers: 42.1, 42.2, 46; 47, 48, 49, 51, 61-64, E30, E42.1	A60		2162.A00019	7830
bearing sleeve + bearing bush: 1x41.1 + 1x41 + 1x42.1 + 1x42.2	E41.1-CO ₂		2162.000233	241
bearing strip + retaining disk: 2x43 + 1x44.1 + 1x44	E42.1-CO ₂		2162.000232	7
set of joints: number x no. : 2x31; 1x32; 9x33 ; 1x34; 1x35; 3x38	E30		2162.000125	33
Counterflange incl. mount. mat. .4 x 24a, 4 x 24b, 2 x 31, 83,	E21		2162.000146	2531
Counterflange incl. mount. mat. 4 x 25a, 4 x 25b, 1 x 32, 84	E22		2162.000145	1600
Blindflange suction side <i>including mounting material</i>	---		2162.002210	3500
Blindflange pressure side <i>including mounting material</i>	---		2162.009100	2650

Parts list HRP10080

	part	HRP 10080			HRP10080 CO ₂		
		dimension	code - no.	Weight [g]	dimension	code - no.	Weight [g]
suction casing	1	DN 100	2162.002011	11420	DN 100	2162.002011	11420
suction intermediate piece	2	Ø196	2162.002015	2160	Ø196	2162.002015	2160
guide vane-interm. piece 1	3	Ø196	2162.002017	4760	Ø196	2162.002059	4760
return intermediate piece	4	Ø196	2162.002020	3940	Ø196	2162.002020	3940
guide vane-interm. piece 2	5	Ø196	2162.002018	3040	Ø196	2162.002018	3040
guide plate for interm. piece 2	5a		2162.002041	126		2162.002041	126
.Screw for guide plate	5b	M6 x 10	5112.BC51A9	5	M6 x 10	5112.BC51A9	5
discharge casing	6	DN 80	2162.002013	5720	DN 80	2162.002013	5720
bearing casing	7	Ø196	A7	2880	Ø196	A7- CO ₂	2880
stator casing	8	Ø196	A8	18000	Ø196	A8- CO ₂	10550
motor cover	9	Ø196	2162.000012	3640	Ø196	2162.000012	3640
can compl. (incl. parts 11-13)	10	Ø95	A10	3645	Ø95	A10- CO ₂	3645
bearing cover	14	Ø79	A10	497	Ø79	A10- CO ₂	497
socket head cap screw	21	M6 x 25	A10	7	M6 x 25	A10- CO ₂	7
socket head cap screw	22	M8 x 365	5112.BH61K4	143	M8 x 365	5112.BH61K4	143
hexagon head cap screw	24a	M16 x 55	5111.AHA1BI	110	M16 x 55	5111.AHA1BI	110
hexagon nut	24b	M16	5151.AHA100	30	M16	5151.AHA100	30
hexagon head cap screw	25a	M 16 x 70	5111.AHA1BX	135	M 16 x 70	5111.AHA1BX	135
hexagon nut	25b	M16	5151.AHA100	30	M16	5151.AHA100	30
torx screw for conn. box	26	4x30 TX20	5143.CLGAAT	3	4x30 TX20	5143.CLGAAT	3
earthing screw	27	M4 x 10	5112.AO31A9	1	M4 x 10	5112.AO31A9	1
long socket head cap screw	28a	M16x285	5112.BHA2HW	462	M16x285	5112.BHA2HW	463
long socket head cap screw	28b	M16	5112.002039	350	M16	5112.002039	350
set screw	29	M6 x 10	A7	1	M6 x 10	A7- CO ₂	1
joint suction flange	31	96/119x1	5632.1CNDAI	7	96/119x1	5632.1CNDAI	7
joint discharge flange	32	77/100x2	5632.1C4CRK	12	77/100x2	5632.1C4CRK	12
joint casing + interm. pieces	33	180/195x0,3	E30	3	180/195x0,3	E30	3
joint can end	34	50/58x0,3	E30	1	50/58x0,3	E30	1
joint motor cover	35	30/40x0,5	E30	1	30/40x0,5	E30	1
joint 1/4" screw plug	38	14/20x1,5	E30	3	14/20x1,5	E30	3
set screw protection	39	Ø 5x5	A7	1	Ø 5x5	A7- CO ₂	1
bearing sleeve I.2 (motor side)	41	40/50x20	E41.1	110	40/50x20	E41.1 - CO ₂	110
bearing sleeve II.2 (pump side)	41.1	40/60x20	E41.1	150	---	---	---
bearing sleeve III (pump side)	41.1-CO ₂	---	---	---	40/70x20	E41.1 - CO ₂	147
bearing bush II (pump side)	42.1	26/60x28	E41.1	240	---	---	---
bearing bush II.3 (pump side)	42.1- CO ₂	---	---	---	26/60x28	E41.1 - CO ₂	220
bearing bush I.2 (motor side)	42.2	26/52x23	E41.1	125	26/52x23	E41.1 - CO ₂	125
bearing strip	43	20/119x1	E42.1	5	20/119x1	E42.1- CO ₂	5
retaining disc (motor side)	44	38,5/52x1	E42.1	2	38,5/52x1	E42.1- CO ₂	2
retaining disc II (pump side)	44.1	39,5/60x1	E42.1	4	---	---	---
retaining disc IV (pump side)	44.1-CO ₂	---	---	---	41,5/70x3	E42.1- CO ₂	6
bearing disc	45	35/50x5	A7	38	35/50x5	A7- CO ₂	38
key	46	6 x 10	5712.AHH001	9	6 x 10	5712.AHH001	9
radial impeller 1	47	Ø 136	A60	660	Ø 136	A60 - CO ₂	660
radial impeller 2	48	Ø 136	A60	520	Ø 136	A60 - CO ₂	520
circlip ring	49	Ø 26	5541.AAP120	2	---	---	---
PTC resistor wire outlet	50	90 °C	A8	---	90 °C	A8- CO ₂	---
transformer oil, 2 L required	51	1,0 L	9832.100001	1425	1,0 L	9832.100001	1425
stator	52	Ø 180	A8	---	Ø 180	A8- CO ₂	---
cable insulating plastic tube	54	---	A8	1	---	A8- CO ₂	1
cable protective tube	55	---	A8	1	---	A8- CO ₂	1
supporting sleeve	56	Ø101,6 x 47	2162.000054	298	Ø101,6 x 47	2162.000054	298
supporting sleeve safety	57	---	2162.000085	6	---	2162.000085	6
screw plug 1/4"	58	---	5116.0G6210	13	---	5116.0G6210	13
cable inlet nipple	59	---	A8	---	---	A8- CO ₂	---
shaft	61	---	A60	---	---	A60 - CO ₂	---
rotor	62	Ø 95	A60	8300	Ø 95	A60 - CO ₂	8300
balancing disc	64	---	A60	260	---	A60 - CO ₂	260
connecting box, compl.	71	98/98/82	2162.002036	670	98/98/82	2162.002036	670
backup fuse for PTC resistor	71a	---	2591.000101	1	---	2591.000101	1
sensor wire	77a	---	A7	1	---	A7- CO ₂	1
sensor wire insulation	77b	---	A7	1	---	A7- CO ₂	1
sensor connecting cover	78	---	A7	15	---	A7- CO ₂	15
sensor inlet nipple	79	---	A7	27	---	A7- CO ₂	27
counterflange suction side	83	DN 100	E21	2320	DN 100	E21	2320
counterflange discharge side	84	DN 80	E22	1625	DN 80	E22	1625
threaded bar	86a	M12x180	5122.BFAJEZ	127	M12x180	5122.BFAJEZ	127
hexagon nut	86b	M12	5151.AH8100	15	M12	5151.AH8100	15
limpet washer	86c	Ø30/13x3	5161.K11100	12	Ø30/13x3	5161.K11100	12
Conical filter, suction side	91	Ø100x160	2196.000005	35	Ø100x160	2196.000005	35
bearing filter	92	Ø57x57	2162.000084	54	Ø57x57	2162.000213	54
ejector	93	---	A7	141	---	A7- CO ₂	141

complete HRP-replacement assemblies and spare part sets

	HRP 10080				HRP 10080 CO ₂		
	Part		Article No.	Weight [g]		Article No.r	Weight [g]
bearing casing with parts: 07, 29, 39, 41.1, 45, 51, 77-79, 93, E30, E42.1	A7		2162.A00089	3200	---	---	---
stator with parts: 08, 50, 51, 52, 54, 55, 59, 71, E30, E42.1	A8		2162.A02032	25520	---	---	---
can with parts: 10, 14, 21, 41.1, 51, E30, E42.1	A10		2162.A02007	3670	---	---	---
balanced shaft, rotor + impellers: 42.1, 42.2, 46; 47, 48, 49, 51, 61-64, E30, E42.1	A60	since 01/10	2162.A00015	12588	---	---	---
bearing sleeve + bearing bush: 1x41.1 + 1x41 + 1x42.1 + 1x42.2	E41.1		2162.000200	241	---	---	---
bearing strip + retaining disk: 2x43 + 1x44.1 + 1x44	E42.1		2162.000202	7	---	---	---
bearing casing with parts: 07, 29, 39, 41.1-CO ₂ , 45, 51, 77-79, 93, E30, E42.1-CO ₂	---	since 01/12	---	---	A7- CO ₂	2162.A00098	5170
stator with parts: 08, 50, 51, 52, 54, 55, 59, 71, E30, E42.1	---	since 01/12	---	---	A8- CO ₂	2162.A00126	25520
can with parts: 10, 14, 21, 41.1, 51, E30, E42.1	---	since 01/12	---	---	A10- CO ₂	2162.A00059	3670
balanced shaft, rotor + impellers: 3, 42.1, 42.2, 46; 47, 48, 49, 51, 61-64, E30, E42.1- CO ₂	---	since 01/12	---	---	A60-CO ₂	2162.A00018	12570
balanced shaft, rotor + impellers: 42.1, 42.2, 46; 47, 48, 49, 51, 61-64, E30, E42.1-CO ₂	---	until 12/11	---	---	A62- CO ₂	2162.A00017	7810
bearing sleeve + bearing bush: 1x41.1 -CO ₂ + 1x41 + 1x42.1-CO ₂ + 1x42.2	---	since 01/12	---	---	E41.1- CO ₂	2162.000233	241
bearing strip + retaining disk: 2x43 + 1x44.1-CO ₂ + 1x44	---	ab 01/2012	---	---	E42.1- CO ₂	2162.000232	7
set of joints: number x no. : 2x31; 1x32; 9x33 ; 1x34; 1x35; 3x38	E30		2162.002037	33	E30	2162.002037	33
.counterflange incl. mount. mat. 4 x 24a, 4 x 24b, 2 x 31, 83,	E21		2162.002038	3535	E21	2162.002038	3535
.counterflange incl. mount. mat. 4 x 25a, 4 x 25b, 1 x 32, 84	E22		2162.000146	2531	E22	2162.000146	2531

Parts list HRP 5050-90 and HRP 8050-90

	HRP 5050-90				HRP 8050-90			
	Part	dimension	code - no	Weight [g]	dimension	code - no	Weight [g]	
suction casing	1	DN 80	2.162.004.004	18500	DN 80	2.162.004.004	18500	
suction intermediate piece	2	Ø196	2.162.001.004	2400	Ø196	2.162.000.028	2250	
guide vane-interm. piece 1	3	Ø196	2.162.001.013	3200	Ø196	2.162.009.002	4000	
return intermediate piece	4	Ø196	2.162.001.006	5140	Ø196	2.162.000.038	3670	
guide vane-interm. piece 2	5	Ø196	2.162.001.008	3520	Ø196	2.162.000.034	3880	
guide plate for interm. piece 2	5a		2.162.002.041	124		2.162.002.041	124	
Screw for guide plate	5b	M6 x 10	5112.BC51A9	5	M6 x 10	5112.BC51A9	5	
discharge casing	6	DN 50	2.162.004.006	7500	DN 50	2.162.004.006	7500	
bearing casing	7	Ø196	E7- CO ₂	3500	Ø196	E7- CO ₂	3500	
Drainage pipe	7a	Ø25x35	E7- CO ₂	17	Ø25x35	E7- CO ₂	17	
Coiled spring pins	7b	3x10	E7- CO ₂	0,3	3x10	E7- CO ₂	0,3	
stator casing	8	Ø196	E8- CO ₂	14214	Ø196	E8- CO ₂	14214	
motor cover	9	Ø196	2.162.004.010	13500	Ø196	2.162.004.010	13500	
can compl. (incl. parts 11-13)	10	---	---	---	---	---	---	
bearing cover	14	---	---	---	---	---	---	
socket head cap screw	21	---	---	---	---	---	---	
socket head cap screw	22	---	---	---	---	---	---	
hexagon head cap screw	24a	M16 x 65	5111.AHA1BS	126	M16 x 65	5111.AHA1BS	126	
hexagon nut	24b	M16	5151.AHA100	30	M16	5151.AHA100	30	
hexagon head cap screw	25a	M16 x 65	5111.AHA1BS	126	M16 x 65	5111.AHA1BS	126	
hexagon nut	25b	M16	5151.AHA100	30	M16	5151.AHA100	30	
torx screw for conn. box	26	4x30 TX20	5143.CLGAAT	2	4x30 TX20	5143.CLGAAT	2	
earthing screw	27	M4 x 10	5112.AO31A9	1,5	M4 x 10	5112.AO31A9	1,5	
long socket head cap screw	28	M20 x 450	5112.BHC3MH	730	M20 x 450	5112.BHC3MH	730	
washer	28a	21x37x3	5161.A11500	1,6	---	---	---	
set screw	29	---	---	---	---	---	---	
joint suction flange	31	77/100 x1	5632.1C4CRI	6	77/100 x1	5632.1C4CRI	6	
joint discharge flange	32	55/77x2	5632.1BIC4K	8,5	55/77x2	5632.1BIC4K	8,5	
joint casing + interm. pieces	33	180/195x0,3	E30	3	180/195x0,3	E30	3	
joint can end	34	---	---	---	---	---	---	
joint motor cover	35	---	---	---	---	---	---	
joint 1/4" screw plug	38	14/20x1,5	E30	3	14/20x1,5	E30	3	
set screw protection	39	---	---	---	---	---	---	
bearing sleeve I.2 (motor side)	41	40/50x20	E41.1 - CO ₂	150	40/50x20	E41.1 - CO ₂	150	
bearing sleeve II.2 (pump side)	41.1	---	---	---	---	---	---	
bearing sleeve III (pump side)	41.1-CO ₂	40/70x20	E41.1 - CO ₂	147	40/70x20	E41.1 - CO ₂	147	
bearing bush II (pump side)	42.1	---	---	---	---	---	---	
bearing bush II.3 (pump side)	42.1-CO ₂	26/60x28	E41.1 - CO ₂	220	26/60x28	E41.1 - CO ₂	220	
Bearing bush I.2 (motor side)	42.2	26/52x23	E41.1 - CO ₂	120,5	26/52x23	E41.1 - CO ₂	120,5	
bearing strip	43	20/119x1	E42.1- CO ₂	5	20/119x1	E42.1- CO ₂	5	
retaining disc	44	38,5/52x1	E42.1- CO ₂	2	38,5/52x1	E42.1- CO ₂	2	
retaining disc II	44.1	---	---	---	---	---	---	
retaining disc II	44.1-CO ₂	41,5/70x3	E42.1- CO ₂	6	41,5/70x3	E42.1- CO ₂	6	
bearing disc	45	35/50x5	E7- CO ₂	38	35/50x5	E7- CO ₂	38	
key	46	6 x 10	5712.AHH001	8,5	6 x 10	5712.AHH001	8,5	
radial impeller 1	47	Ø 136	2.162.001.016	455	Ø 136	2.162.009.008	535	
radial impeller 2	48	Ø 136	2.162.001.017	430	Ø 136	2.162.009.009	485	
circlip ring	49	---	---	---	---	---	---	
PTC resistor wire outlet	50	90 °C	E8- CO ₂	---	90 °C	E8- CO ₂	---	
transformer oil, (2 L required)	51	---	---	---	---	---	---	
stator	52	Ø 180	E8- CO ₂	15260	Ø 180	E8- CO ₂	15260	
cable insulating plastic tube	54	---	E8- CO ₂	1	---	E8- CO ₂	1	
cable protective tube	55	---	E8- CO ₂	1	---	E8- CO ₂	1	
supporting sleeve	56	---	---	---	---	---	---	
supporting sleeve safety	57	---	---	---	---	---	---	
screw plug 1/4"	58	---	5116.0G6210	15	---	5116.0G6210	15	
cable inlet nipple	59	---	E8- CO ₂	---	---	E8- CO ₂	---	
shaft	61	---	E60- CO ₂	---	---	E60- CO ₂	---	
rotor	62	Ø 95	E60- CO ₂	3700	Ø 95	E60- CO ₂	3700	
balancing disc	64	---	E60- CO ₂	340	---	E60- CO ₂	340	
connecting box, compl.	71	98/64/38	E60- CO ₂	678	98/64/38	E60- CO ₂	678	
backup fuse for PTC resistor	71a	---	2.591.000.101	1	---	2.591.000.101	1	
sensor wire	77a	---	---	---	---	---	---	
sensor wire insulation	77b	---	---	---	---	---	---	
sensor connecting cover	78	---	---	---	---	---	---	
sensor inlet nipple	79	---	---	---	---	---	---	
counterflange suction side	83	DN80	E21	2560	DN80	E21	2560	
counterflange discharge side	84	DN50	E22	1580	DN50	E22	1580	
threaded bar	86a	M12x180	5122.BFAJEZ	127	M12x180	5122.BFAJEZ	127	
hexagon nut	86b	M12	5151.AH8100	15	M12	5151.AH8100	15	
limpet washer	86c	Ø30/13x3	5161.A11100	6	Ø30/13x3	5161.A11100	6	
Conical filter, suction side	91	Ø83/76x160	2.196.000.004	24	Ø83/76x160	2.196.000.004	24	

bearing filter	92	Ø57x57	2.162.000.213	39	Ø57x57	2.162.000.213	39
ejector	93	---	E7- CO ₂	80	---	E7- CO ₂	80
Protective sleeve	94	Ø100x61	2.162.004.019	157	Ø100x61	2.162.004.019	157
Screws for protective sleeve	95	M4x16	5112.BC31AF	5	M4x16	5112.BC31AF	5
Cable gland	96	M25x1,5	5.191.000.125	15	M25x1,5	5.191.000.125	15
Cable gland	97	M16x1,5	5.191.000.116	6	M16x1,5	5.191.000.116	6
Sealing insert	98	Ø10	6491.EB0100	1	Ø10	6491.EB0100	1

complete HRP-replacement assemblies and spare part sets

	HRP 5050-90			HRP 8050-90		
	Part	code - no	Weight [g]	Part	code - no	Weight [g]
Balanced shaft, rotor + impellers: 42.1- CO ₂ , 42.2, 46; 47, 48, 61-64	E60- CO ₂	2.162.004.022	9700	E60- CO ₂	2.162.004.023	9800
bearing casing with parts: 07, 7a, 7b, 41.1-CO ₂ , 45, 93	E7- CO ₂	2.162.004.025	3400	E7- CO ₂	2.162.004.025	3400
stator with parts: 08, 50, 52, 54, 55, 59, 71	E60- CO ₂	2.162.004.027	38550	E8- CO ₂	2.162.004.027	38550
bearing sleeve + bearing bush: 1x41.1-CO ₂ + 1x41 + 1x42.1-CO ₂ + 1x42.2	E41.1-CO ₂	2.162.000.233	688	E41.1-CO ₂	2.162.000.233	688
bearing strip + retaining disk: 2x43 + 1x44.1-CO ₂ + 1x44	E42.1-CO ₂	2.162.004.028	15	E42.1-CO ₂	2.162.004.028	15
set of joints: number x no. : 2x31; 1x32; 9x33 : 1x34; 1x35; 3x38	E30	2.162.000.125	43	E30	2.162.000.125	43
..Counterflange suction side incl. mount. mat. 4 x 24a, 4 x 24b, 2 x 31, 83,	E21	2.162.004.153	3600	E21	2.162.004.153	3600
..Counterflange discharge side incl. mount. mat. 4 x 25a, 4 x 25b, 1 x 32, 84	E22	2.162.004.152	2300	E22	2.162.004.152	2300

4.7 DESCRIPTION OF OPERATION

From the surge drum refrigerant liquid flows into the suction chamber of the pump. In the suction connection a conical screen is placed. A special design of the suction chamber reduces the inlet friction. The pressure is increased in two stages through impellers and intermediate pieces. A built in ejector is designed to provide adequate cooling of bearings and motor.

By the differential pressure in the pump some of the liquid refrigerant is bled to the back bearings through the hollow shaft. On top of each intermediate piece there is a small bypass hole connecting the suction and discharge side. When gas has collected in the discharge chamber it can vent through these holes to the suction chamber and from there returning to the surge drum. It is important that the downleg must be designed in such a way that the pump venting can take place (see chapter 6).

For the HRP 3232, 5050-90 and 8050-90 the design of a vertical motor shaft allows the free flow of any gas bubbles that may form.

Pumps with horizontal motor shaft (HRP 5040, HRP 5050, HRP 8050 and HRP 10080) are equipped with a sensor behind the bearing filter to detect wear of the bearings. While the pump is at stand still at connection (position 77) on the out-side of the pump you can measure the electrical resistance through the shaft. If there is a short circuit, i.e. down to earth, the bearings are worn and the pump should be sent in for repair.

Transformer oil is used in the stator housing between the motor can and the outside casing. This oil is useful to prevent moisture entering the stator, conducts the motor heat away to the outside casing.

A thermistor is integrated in the stator windings to sense any abnormal rise in temperature and interrupt the motor supply.

4.8 PERFORMANCE CHARACTERISTIC TABLE

50 Hz, 3 x 400V													
	Druckdifferenz Δp [bar]								Volumenstrom V[m ³ /h]				
	Pressure difference Δp [bar]								Volume flow V[m ³ /h]				
	R717		R22, R134a		R507		CO ₂		HRP 3232	HRP 5040	HRP 5050	HRP 8050	HRP 10080
Delivery head	at evaporation temperature t_0												
H [m]	0°C	-40°C	0°C	-40°C	0°C	-40°C	0°C	-40°C					
2	0,13	0,14	0,25	0,28	0,23	0,25	0,18	0,22	5,6	13,2	15	30,0	55,0
4	0,25	0,27	0,50	0,55	0,45	0,51	0,36	0,44	5,0	13,0	14,6	29,9	53,7
6	0,38	0,41	0,75	0,83	0,68	0,76	0,55	0,66	4,7	12,6	14,4	29,4	53,0
8	0,50	0,54	1,00	1,10	0,91	1,02	0,73	0,88	4,4	12,0	14,2	28,7	52,5
10	0,63	0,68	1,26	1,38	1,14	1,27	0,91	1,09	4,2	10,5	13,9	28,0	52,1
15	0,94	1,02	1,88	2,07	1,70	1,91	1,37	1,64	3,6	9,0	13,2	26,1	50,3
20	1,25	1,35	2,51	2,76	2,27	2,54	1,82	2,19	3,0	8,0	12,3	24,2	46,8
25	1,57	1,69	3,14	3,45	2,84	3,18	2,28	2,74	2,3	5,2	11,5	22,4	42,6
30	1,88	2,03	3,77	4,14	3,41	3,82	2,73	3,28	-	1,5	10,4	20,1	37,9
35	2,19	2,37	4,40	4,83	3,97	4,45	3,19	3,83	-	-	9,1	18,2	32,7
40	2,51	2,71	5,02	5,52	4,54	5,09	3,64	4,38	-	-	7,5	15,0	26,6
45	2,82	3,05	5,65	6,21	5,11	5,72	4,10	4,93	-	-	5,2	12,5	20,4
50	3,13	3,39	6,28	6,90	5,68	6,36	4,55	5,47	-	-	2,0	9,1	10,9
55	3,45	3,72	6,91	7,59	6,24	7,00	5,01	6,02	-	-	-	-	-
60	3,76	4,06	7,53	8,28	6,81	7,63	5,46	6,57	-	-	-	-	-
65	4,07	4,40	8,16	8,97	7,38	8,27	5,92	7,11	-	-	-	-	-
70	4,39	4,74	8,79	9,66	7,95	8,90	6,37	7,66	-	-	-	-	-
75	4,70	5,08	9,42	10,35	8,52	9,54	6,83	8,21	-	-	-	-	-

60 Hz, 3 x 460V													
	Druckdifferenz Δp [bar]								Volumenstrom V [m ³ /h]				
	Pressure difference Δp [bar]								Volume flow V [m ³ /h]				
Delivery head	R717		R22, R134a		R507		CO ₂		HRP 3232	HRP 5040	HRP 5050	HRP 8050	HRP 10080
	at evaporation temperature t_0												
H [m]	0°C	-40°C	0°C	-40°C	0°C	-40°C	0°C	-40°C					
2	0,13	0,14	0,25	0,28	0,23	0,25	0,18	0,22	5,2	13,9	16,4	35	66,1
4	0,25	0,27	0,50	0,55	0,45	0,51	0,36	0,44	5,2	13,8	16,3	35	66,0
6	0,38	0,41	0,75	0,83	0,68	0,76	0,55	0,66	5,1	13,6	16,2	35	65,6
8	0,50	0,54	1,00	1,10	0,91	1,02	0,73	0,88	5,0	13,4	16,0	35	64,8
10	0,63	0,68	1,26	1,38	1,14	1,27	0,91	1,09	4,8	13,3	15,9	35	63,7
15	0,94	1,02	1,88	2,07	1,70	1,91	1,37	1,64	4,7	12,8	15,4	34,8	60,8
20	1,25	1,35	2,51	2,76	2,27	2,54	1,82	2,19	4,4	12,1	14,9	32,8	57,9
25	1,57	1,69	3,14	3,45	2,84	3,18	2,28	2,74	4,1	11,2	14,3	30,7	54,8
30	1,88	2,03	3,77	4,14	3,41	3,82	2,73	3,28	3,6	10,1	13,7	28,5	51,3
35	2,19	2,37	4,40	4,83	3,97	4,45	3,19	3,83	3,0	8,8	13,1	26,6	47,7
40	2,51	2,71	5,02	5,52	4,54	5,09	3,64	4,38	2,2	7,3	12,3	24,7	44,0
45	2,82	3,05	5,65	6,21	5,11	5,72	4,10	4,93	1,1	5,7	11,5	22,9	39,7
50	3,13	3,39	6,28	6,90	5,68	6,36	4,55	5,47	-	3,6	10,5	20,7	34,1
55	3,45	3,72	6,91	7,59	6,24	7,00	5,01	6,02	-	-	9,4	18,3	28,5
60	3,76	4,06	7,53	8,28	6,81	7,63	5,46	6,57	-	-	7,9	15,7	23,0
65	4,07	4,40	8,16	8,97	7,38	8,27	5,92	7,11	-	-	6,0	13,0	14,0
70	4,39	4,74	8,79	9,66	7,95	8,90	6,37	7,66	-	-	2,6	9,7	-
75	4,70	5,08	9,42	10,35	8,52	9,54	6,83	8,21	-	-	-	-	-

Table 1

In CO₂-systems with minimum flow line the given volume flow is not fully available for the system. A part of the pump volume flow will be by-passed via minimum flow line back into the vessel.

5. APPLICATIONS

5.1 GENERAL

In industrial refrigeration systems pumps are used to deliver refrigerant to the evaporators. WITT hermetic refrigerant pumps are designed especially for this purpose. The principle of a pump re-circulation system is shown in fig. 4.

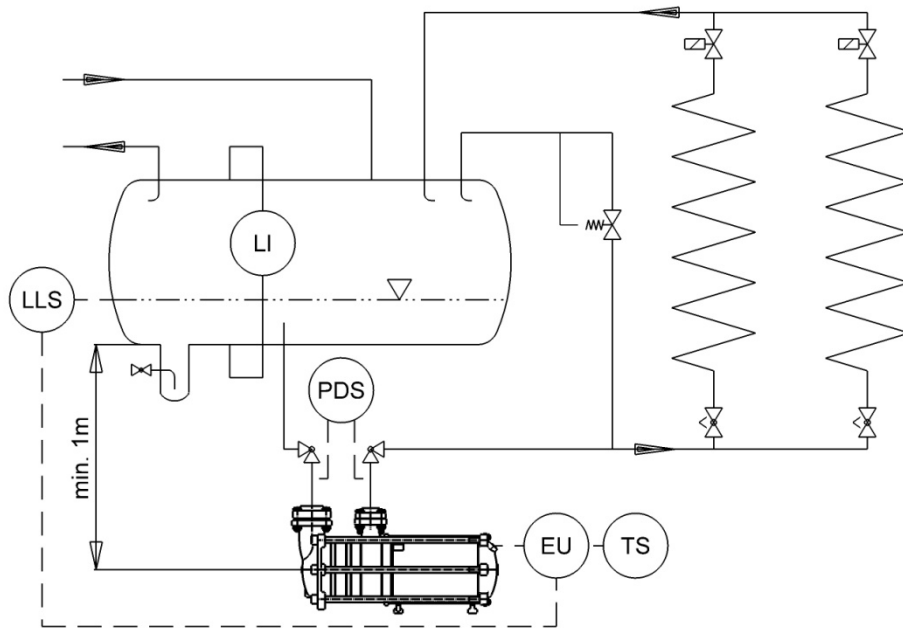

Fig. 4 principle of pump re-circulation system

WITT HRP refrigerant pumps differ from conventional centrifugal pump designs due to the fact that large volumes of entrained vapour (gas bubbles) do not completely stop delivery of the refrigerant liquid.

Large volumes of gas occur in the pump suction when the evaporation temperature of the plant varies during the production cycle, particularly when starting the compressor (pull-down) and during the rapid loading or unloading of compressor steps of capacity.

Large amounts of gas bubbles in the pump suction line will cause the mass flow of liquid refrigerant to be reduced.

Special attention has to be taken to ensure that the pump suction lines are generously sized.



It is important hermetic pumps are supplied with liquid refrigerant at all times. Long periods of cavitation must be avoided, as this will cause premature failure of the pump. It is important the installation instructions in chapter. 6 are correctly understood and followed.

When a minimum flow into the system can be guaranteed at all times, no by-pass lines are required (see chapter 6)

OPERATIONAL LIMITATIONS

All HRP pumps are suitable for use at 50/60 Hz and all common refrigerants, e.g. NH₃, CO₂, R134a, R404a, R410, R507, etc.



HRP8050 requires, when operated with synthetic refrigerants (HFC, HFO), e.g. R134a, R404A, R410, R507, a larger motor. Therefore these re-frigerants must be specified when ordering!

A horizontal separator is recommended: this gives greater surface area for the settlement of any oil and stable

suction head conditions.

5.2 DETERMINATION OF THE DELIVERY HEAD

The required delivery head is the resistance the pump needs to overcome to supply the evaporator with the high-est pressure loss with sufficient liquid refrigerant (in most cases this will be the furthest distant evaporator).

The delivery head is depending from:

- Height difference between pumps and evaporators
- Resistance of pipe work and evaporators
- Pressure losses of valves and fittings in the delivery line
- Density of the refrigerant

The max. allowable delivery head should never be exceeded, because otherwise the pump is operated outside the permitted range and will see internal damages (see chap. 6.5)

5.3 DETERMINATION OF THE REQUIRED FLOW

The evaporators have to be supplied with sufficient liquid refrigerant, so that

- The surface of the evaporators is fully used
- Supply to several evaporators with different duties is as even as possible.

The re-circulation rate is calculated as follows:

$$\text{Re - circulation rate} = \frac{\text{mass flow pump}}{\text{evaporated refrigerant}} = \frac{M_{\text{pump}}}{M_{Q0}}$$

A re-circulation factor of 4 means that 3 parts refrigerant are returned as liquid and 1 part is evaporated.

The re-circulation rate depends on the type of evaporator equipment and operation conditions.

The larger the duty, loading rate, the greater the recommended re-circulation factor.

RE-CIRCULATION RATES AND PUMP CAPACITY

Refrigerant	Recirculation factor			Recirculation flow in m ³ /hr per 100 kW*		
	CO ₂	NH ₃	R22	CO ₂	NH ₃	R22
Air Cooler	1,2 – 2,0	1,2 - 4	2 - 3	1,4 – 2,4	1,3 – 1,8	2,8 – 4,3
Plate Freezer	5 - 10	7 - 10	5 - 10	6 - 12	3 – 4,5	6,5 - 13
Liquid Chiller	1,2 – 1,5	1,2 – 1,5	1,2 – 1,5	1,4 – 1,6	0,6	1,7

*) including re-circulation rate

Table 2

5.4 ADAPTATION TO PLANT REQUIREMENTS

Fig. 5 shows different plant operating conditions. The delivery head H is shown in relation to the required plant capacity Q .

Performance curve characteristics of the refrigerant pump are shown in fig 5A. The different points W mark the varying plant conditions that may occur during operation.

If the required liquid flow does not correspond with the available pump capacity then the liquid flow to the system can be adjusted as follows:

pump capacity too large:



- switch off a pump
- open a liquid bypass valve, fig. 5B
- speed control of the pump, fig 5C

pump capacity too small:

- switch on an extra pump, fig 5D
- install a larger pump

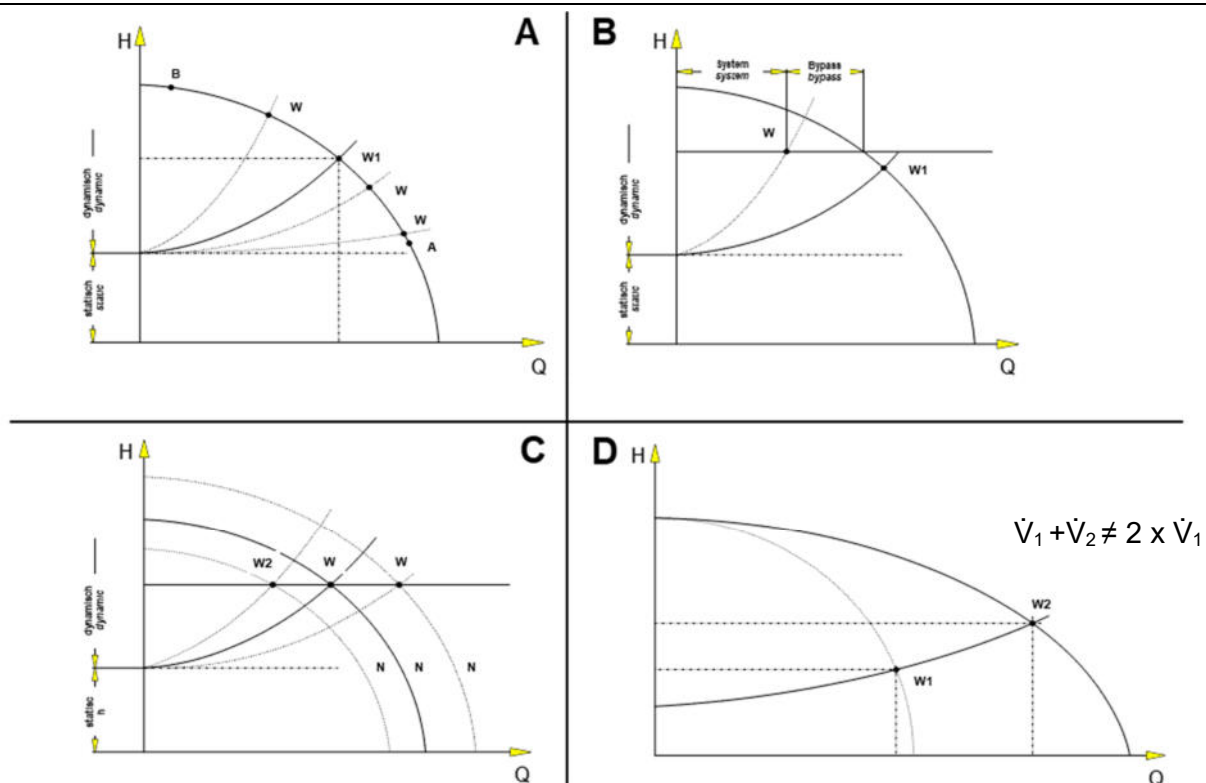

Fig. 5, A-D

5.5 USE OF FREQUENCY CONVERTERS

When using frequency converters the frequency should never be less than 40 Hz to ensure the minimum required refrigerant flow is maintained.

The start/stop ramp should be set steep enough, so the check valve on the discharge valve can open fast enough. (From experience the ramp should be set at 1 s).

Since a differential set overflow valve cannot be used for the varying pressure differences over the pump, it must be ensured in a different way that there is always sufficient flow through the pump.

If operating against closed evaporators is possible, a permanent open bypass line is required.

Further information regarding recommended control systems can be found in the annex at the end.

6. INSTALLATION INSTRUCTIONS

To ensure trouble free operation some basic rules need to be applied to the installation of the HRP pumps.

6.1 PUMP ARRANGEMENT



The installation must be designed as compact as possible below the separator or low-pressure receiver. Allow sufficient access space around the pumps for removing or replacing the pump, servicing valves, setting pressure difference control, inspection and cleaning the conical strainer. Also allow space for normal frost/ice accumulation around the pump.



Vertical distance between bottom of the separator to the pump centre shall be at least 1 m. Greater distance will make the pump less sensitive to system pressure fluctuations.



Particularly with CO₂ applications of temperatures warmer than -10°C a minimum suction head of 1,5 m is required!

The downleg should be positioned in such a way that gas entrainment from the return line is minimised (e.g. installation of the return line with an elbow in a safe distance).



The suspended mounting of the pumps with threaded bars of at least 180 mm length is recommended. HRP 5040, HRP5050, HRP8050 and HRP10080 should be aligned horizontally, the HRP 3232, 5050-90 and 8050-90 must be aligned vertically due to their design.

Please consider that

- A condensate trip tray can easily be placed and cleaned.
- The conical suction line filter can be cleaned easily.
- Stress in the piping system is avoided.

6.2 PUMP CONNECTION

The top connection of the suction line to the separator can be made with a down pipe with vortex breaker.

The vortex breaker shall consist of crossed plates with a baffle plate on top to avoid any vortexing. Vortex breakers are available from TH. WITT.

Above the baffle plate of the vortex breaker there should be at least 15mm refrigerant level (in CO₂ systems a minimum coverage of 50mm is required).



When using non-soluble oils in ammonia systems special attention must be taken that any oil, which may settle, does not drain into the duty or stand-by pump.

Therefore it is recommended that the suction down leg protrudes into the surge drum by 30 - 40 mm, depending on the vessel diameter (see fig. 6a).

A standard short oil drainage dome is not suitable for connecting a pump suction down leg.

Do not connect two or more pumps in operation by a single common pump suction line liquid header.

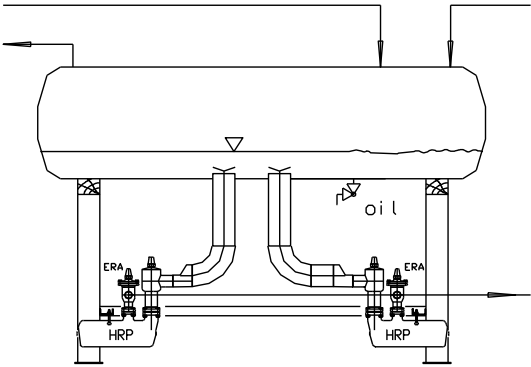

Application with two pumps in operation

Fig. 6a

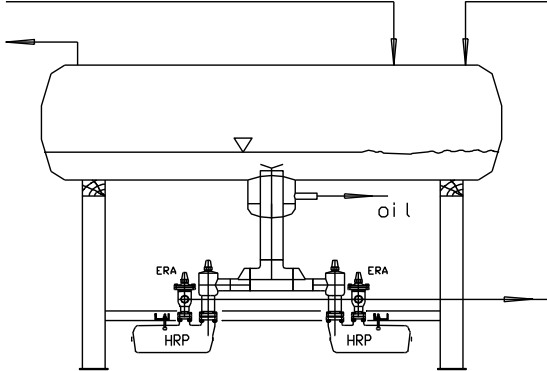

Application with one pump in operation and one in stand-by (NH₃)

Fig. 6b

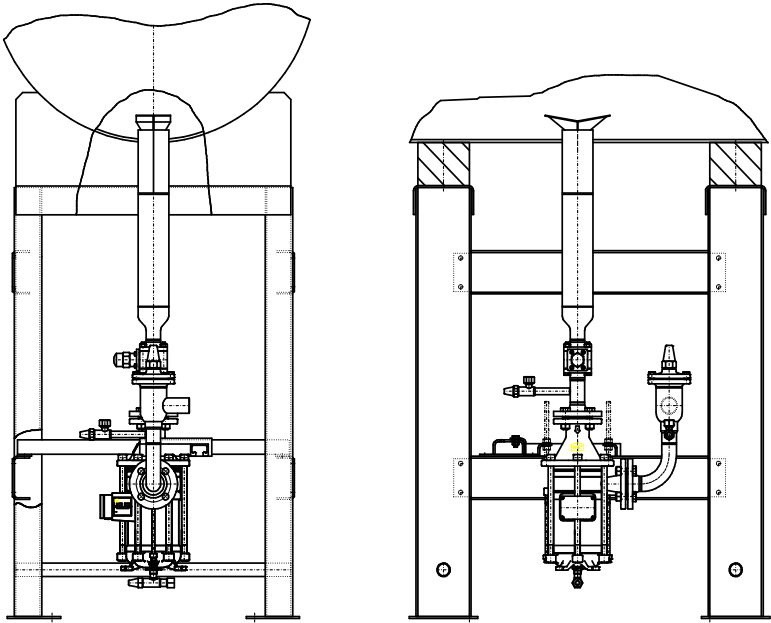

Fig. 6c Arrangement of HRP 3232

6.3 DOWNLEG DESIGN

The pump shall be connected vertically with the separator. To prevent interference between pumps it is advised that each pump be connected individually to the separator, see fig. 6a.

When a stand-by pump is planned, an installation according fig. 6b is recommended.

To avoid any vortexing the downleg here again protrudes into the separator.

An oil drainage dome around the suction line, as shown in fig. 6b, can be favourable.

Consideration shall be given to the fact that the suction line must be installed directly to the pump, avoiding additional elbows or horizontal run.

Any gas accumulation in the suction line and particularly in valves attached to the pump must be avoided. Gas bubbles should be able to flow back to the separator unhindered, counter to the liquid flow, especially when the pump is not in operation.



When there is no separate vent line installed it is important the pumps can vent to the suction side, which means the suction downleg must be open during stand-still.

Shut off valves in the suction line shall be sized generously and without reducers to enable degassing. Installation of full-bore ball valves are recommended. Straight through valves must be installed with stem in horizontal position; ball valves should not have a reduced bore on the pump side connection.

Until now we have not recommend filters in the liquid downleg as these create additional pressure loss. However, positive experience has proven that the use of filters in systems with high levels of contamination (i.e. due to installation of non-shot blasted pipes and vessels) is better than contamination of the pump.

Filters with a mesh of 500 μm (e.g. Parker T5F-SS, AWP-SS, RFF FA or Danfoss FIA) should be installed in systems with a potential for contamination.



Upmost care should be taken to clean the filters as often as possible during the first weeks of operation, until they remain clean.

Since external filters have a larger filter surface and can be cleaned more easily, we recommend you keep these in place and remove the conical filter in the pump inlet to avoid two filters causing excessive pressure drop. A regular check (1 – 2 per year) should be included in the maintenance routine.



To be sure the pump will operate even at a low-pressure difference resulting in maximum capacity, the diameter of the downleg to the pump must be executed as mentioned in the table below as a minimum!

Required diameter of the downleg to the pumps					
	HRP 3232	HRP 5040	HRP 5050	HRP 8050	HRP 10080
50 Hz	DN 80	DN 100	DN 125	DN 150	DN 250
60 Hz	3"	4" / 5"	5"	6" / 8"	10"

Table 3



Under no circumstances shall the maximum velocity of ammonia systems in the downleg exceed **0,3 m/s!**

Systems operating at 60Hz have to select a DN125 (5") suction line when the delivery head is below 25 m for HRP5040, whereas the HRP8050 requires below 40 m a DN200 (8") suction line diameter.

The conical suction filter that comes with the pump must be fitted at all times to protect the pump from any contamination!

6.4 PUMP DISCHARGE LINE

The design of the discharge line is less critical to the system operation. A liquid velocity of 1.5 m/s is normally recommended.



A non-return valve (this is usually a combined stop/check valve type ERA) in the discharge line is required when a backwards flow from the discharge to the suction side is possible. This may be the case, when:

- several pumps are connected to one discharge manifold
- the static head to the coolers is high.

A non-return valve should be mounted as close as possible to the discharge flange. If a larger distance is required, an additional vent line should be installed to prevent a possible gas blockage.

VENT LINE

If the suction line needs to be closed during stand-still or the check valve is installed in a distance from the pump an additional vent line is required.

A minimum flow line is always recommended in CO₂ systems, which also vents the pump during stand-still.

To avoid backflow of refrigerant during stand-still it is important that each pump is individually connected with a separate vent line immediately in front of the check valve on the delivery side to the top of the surge drum.

The stop valve after the orifice shall be DN20 (3/4") respective DN25 (1") if installed in the part of the vent line that can contain liquid.

If the valve is installed in the gas part of the vent line, immediately in front of the connection point to the CO₂ vessel a smaller valve is sufficient, e.g. DN10 (0.4"). The stop valve must be locked in an open position and marked "do not close during normal operation".



In application with a non-return valve or solenoid valve liquid may be trapped. When this liquid is warmed up, the pressure increases rapidly to an unacceptable value and the piping may fracture.

Adequate precautions must be taken by the installer to prevent any liquid from becoming trapped.

PIPING FROM THE CONDENSER IN CO₂ SYSTEMS

From experience it has proven good practice to enter with the line from the condenser into the surge drum below the liquid level and as such minimize the surface available for condensation in the vessel.

6.5 PROTECTION OF THE PUMP

6.5.1 REQUIRED MINIMUM FLOW

To provide the pumps with sufficient liquid refrigerant for lubrication and cooling it is important to maintain a minimum flow per following table through the pump at all times. This can be achieved when the design or the control system ensures there is always sufficient flow to the evaporators.

When the control system allows that a major part or all evaporators can be closed, a by-pass line is required to protect the pump against too high pressure (see chap. 6.5.2) and ensure a minimum flow.

Required minimum flow				
	V @ 50 Hz		V @60 Hz	
	m ³ /h	gal/min	m ³ /h	gal/min
HRP3232	0,6	2.6	0,7	3.1
HRP5040	1,2	5.3	1,5	6.6
HRP5050	3,0	13,2	3,5	15,4
HRP8050	5,0	22	5,5	24
HRP10080	8,0	35	9,6	42

6.5.3 SAFEGUARDING AGAINST TOO HIGH PRESSURE



Operating refrigerant pumps against too high pressure (e.g. against partially or fully closed throttled condition) is not allowed and will damage the refrigerant pump!

A **by-pass valve** (adjustable) has proven good practice to safeguard the pump against too high pressure, with the exception of CO₂ systems.

To set the by-pass valve select the pressure difference across the pump according table 1 for the following de-livery head. (take into account the pressure losses in the pipework to the by-pass valve)

	40Hz	45Hz	50Hz	55Hz	60Hz
HRP 10080	30 m	38 m	45 m	52 m	60 m
HRP 8050	30 m	38 m	45 m	52 m	60 m
HRP 5050	28 m	36 m	45 m	52 m	60 m
HRP 5040	16 m	22 m	30 m	36 m	45 m
HRP 3232	13 m	18 m	25 m	31 m	37 m

The following tables give the settings of a differential pressure operated overflow valve (e.g. A4AL or CVP-PP) for several refrigerants at evaporation temperatures of 0°C (32°F), -10°C (14°F) and -40°C (-40°F) and 50Hz respective 60 Hz.

The settings are also mentioned in our selection program.

50 Hz, 3 x 400V								
Set point Δp	Evap. Temp.		NH3		R404A/R507A		R134a	
	°C	°F	[bar]	[psi]	[bar]	[psi]	[bar]	[psi]
HRP3232	0	32	1,5	22	2,8	41	3,1	22
	-10	14	1,6	23	2,9	42	3,2	47
	-40	-40	1,7	24	3,1	45	3,4	50
HRP5040	0	32	1,8	27	3,4	49	3,8	55
	-10	14	1,9	28	3,4	51	3,9	56
	-40	-40	2,0	29	3,7	54	4,1	60
HRP5050	0	32	2,8	41	5,1	73	5,7	82
HRP8050	-10	14	2,8	42	5,2	76	5,8	85
HRP10080	-40	-40	3,0	44	5,6	82	6,2	90

60 Hz, 3 x 460V								
Set point Δp	Evap. Temp.		NH3		R404A/R507A		R134a	
	°C	°F	[bar]	[psi]	[bar]	[psi]	[bar]	[psi]
HRP3232	0	32	2,5	36	4,5	65	5,0	73
	-10	14	2,5	37	4,6	68	5,2	76
	-40	-40	2,7	39	5,0	73	5,5	80
HRP5040	0	32	2,8	40	5,1	73	5,7	83
	-10	14	2,8	42	5,2	76	5,8	85
	-40	-40	3,0	44	5,6	82	6,2	90
HRP5050	0	32	3,7	54	6,7	98	7,6	110
HRP8050	-10	14	3,8	56	7,0	102	7,8	114
HRP10080	-40	-40	4,0	59	7,5	109	8,3	120



The adjustable by-pass valve shall be sized according to the following values: DN 20 for the HRP 3232 and HRP5040, DN 25 for the HRP 5050 and HRP 8050 and DN32 for HRP10080.

Experience of various CO2 installations revealed that pressure regulated overflow valves do not work reliable. When it is not certain the required minimum flow per chap. 6.5.1 is always available, a **MINIMUM FLOW LINE** with permanent open orifice per following table is required

It is recommended each pump receives it's individual minimum flow line. This will also serve as vent line during stand-still.

DIMENSIONS OF THE MINIMUM FLOW LINE IN CO2 SYSTEMS

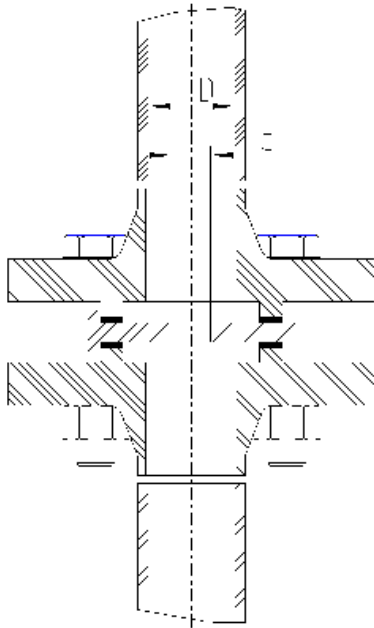

3rd
WORKFILE CROSS.DAT

50 HZ					
	D		orifice part		
	mm*	inch**		mm*	inch**
HRP3232	27,3	0,96	4419.020104	4,0	0,16
HRP 5050	27,3	0,96	4419.020103	7,0	0,28
HRP 8050	27,3	0,96	4419.020101	9,8	0,38
HRP10080	27,3	1,28	4419.020102	12,0	0,47

60 HZ					
	D		orifice part		
	mm*	inch**		mm*	inch**
HRP3232	27,3	0,96	4419.020114	4,0	0,16
HRP 5050	27,3	0,96	4419.020113	7,0	0,28
HRP 8050	27,3	0,96	4419.020111	9,5	0,38
HRP10080	27,3	1,28	4419.020112	12,5	0,47

* mm values for DIN pipes /

** inch values reference schedule 80 pipe

*** Article orifice consisting of: flanges, orifice, gasket, bolts and nuts

6.5.4 MINIMUM STAND-STILL PERIOD

A restart of the pump is only allowed when the pump has been able to vent correctly. The minimum stand-still time to achieve correct venting is determined by the type of refrigerant and the evaporating temperature. For ammonia applications the pump will normally require 3 to 5 min. For CO₂ systems this period should be increased to 15 min, or for warmer CO₂ (>-10°C) to at least 20 min. With a minimum flow line the time to vent the pump is reduced to about 5 min.

When the downleg is closed during stand-still it takes longer (possibly more than 20 min) to vent all gas through the pump internal vent hole, once the suction valve has been fully opened (normally until frost is formed in the motor area). If a waiting period is to be avoided, a small vent line is required (see chap. 6.4).

6.5.5 MINIMUM OPERATION TIME

The highest heat impact for the pump takes place when the starting torque of the motor consumes the highest current. Therefore a minimum operation time of 1 to 2 minutes (in CO₂ systems 5 minutes) should be programmed to allow for stable operating conditions.

6.5.6 DRY-RUN PROTECTION

If a **minimum level cut out switch** is mounted on the separator, it shall be used to switch the pump off in case of a lack of refrigerant (dry run protection).

6.5.7 PRESSURE DIFFERENTIAL SWITCH

A PRESSURE DIFFERENTIAL SWITCH - with time delay during start up - shall be used when there is insufficient discharge pressure.

The delay should be set at 30 to 60 s, which means if the pump was not able to build up pressure (e.g. 0,3 – 0,5 bar) within 30 s, the pump will be stopped

This procedure can be repeated a maximum of four times. Then a malfunction message should be submitted and the pump switched off. After that a restart should only be made after investigation of the cause of failure and acknowledging the fault indicator.

The pressure differential switch does not protect the pump against too high pressure running (dead heading)!

6.5.8 FLOW SWITCH

A flow switch is recommended if the overflow valve has been omitted and shut-off from all evaporators may occur. It is known that the pump is capable of producing a differential pressure without volume flow and is not switched off by the differential pressure switch.

The flow switch control in the pump discharge shall stop the flow as the flow drops below 0,2 m/s.

6.6 ELECTRICAL INFORMATION

The following equipment must be provided in the electric control circuit of the motor:

6.6.1 OVERLOAD PROTECTION

An overload protection switch shall protect the pump against too high current (amps) consumption. Maximum setting must be less than max. allowable current I_{max} for the selected refrigerant. See chapter 4.2.

6.6.4 NIL VOLTAGE BEARING CONDITION TEST

For the horizontal pump models it is possible to detect bearing wear during pump stand still. The external end of the sensor wire under the cap (77) can be used to measure the electrical resistance.

When a closed circuit with the pump housing is observed, the bearings are worn and the pump must be sent to the supplier for repair.

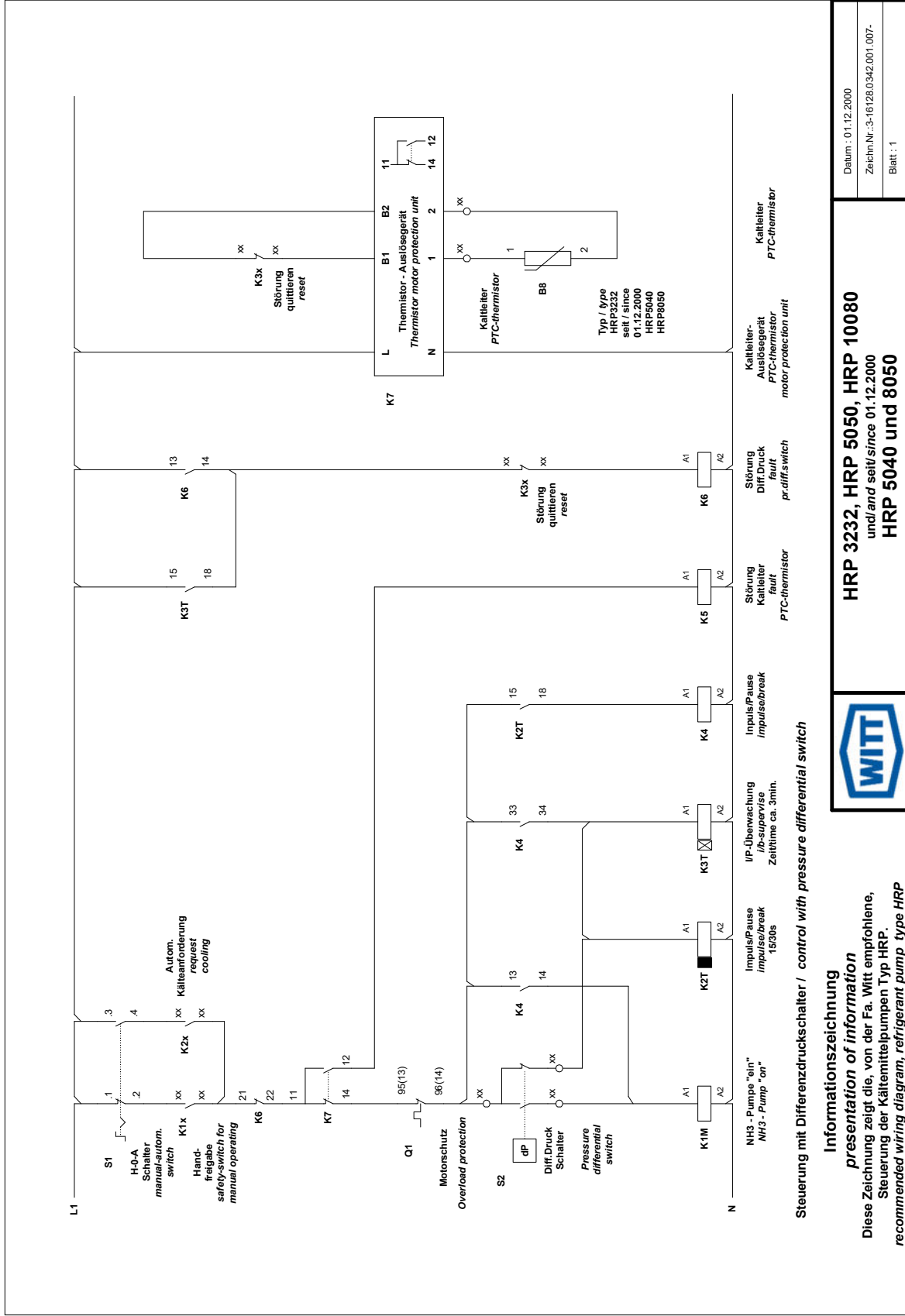

Fig. 7b Recommended electrical wiring diagram with differential pressure switch

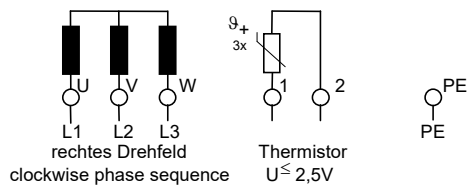

Fig. 8A

Wiring information inside the terminal box

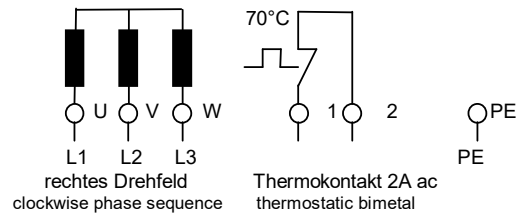

Fig. 8B

Old execution of HRP 8050 and HRP 5040 until 12/2000

The correct direction of rotation, indicated by the cast arrow on the pump housing, is obtained if the electric connections are made as detailed in the terminal box electric wiring diagram, fig. 8, with the phase sequence rotating clockwise. The direction of the phase sequence can be measured with specific measuring equipment. The electrical connection information is also available on the label inside the cover of the terminal box; see fig. 8.

The terminal box has two sizes of cable sockets. All cable and electrical connections including the terminal box have to be made to IP 54.

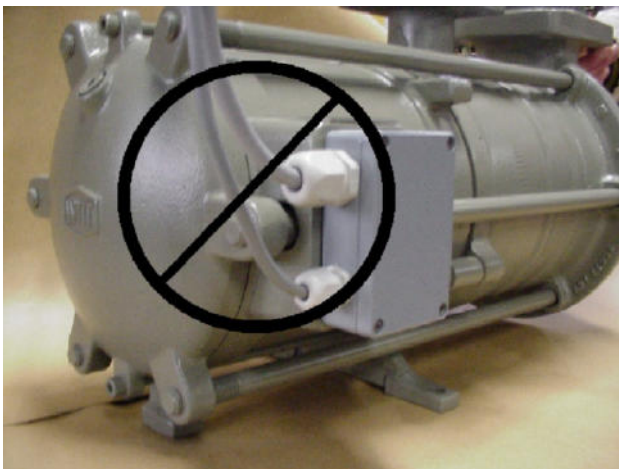

Fig. 9 a Wrong connection



Fig.9 b Correct connection with loop in electrical cable

It is important that all electrical cables are connected with a loop to the terminal box (see fig 9 b.)

By using a loop any condensate that may run along the cable is prevented from running into the terminal box.

The terminal box must be sealed at all times, to prevent dirt and moisture to come in; also touching of the connections has to be avoided.

The length of the loop shall be of sufficient length to enable the tilting and moving of the pump during inspection and replacement of the conical strainer in the pump suction connection.

7. TRANSPORT_AND_STORAGE

All connections are protected with yellow plastic caps to prevent any dirt or moisture contaminates the pump.

Storage shall be dry and protected from any dirt or debris.

Please lift the pumps according to the following photos.



 The terminal box must not be used when lifting the pump!

8. INSTALLATION AND APPLICATION



All of the following specified work must be carried out by knowledgeable and trained personnel experienced in installation and service of refrigeration systems!

8.1 PREPARING THE PUMP FOR INSTALLATION

Before the pump is installed the following functions should be carried out:

- unpack the pump and check for possible damage during shipping and the correct scope of equipment supplied. Pay special attention to the electric terminal box and the connection of the sensor wire (77). In case of any damages inform your supplier immediately.
- Excepts sensore wire cap (78,) remove all plastic caps or other sealings immediately prior to (and not before) installation of the pump.
- check that the conical suction strainer has been supplied and that the gaskets are on both sides of the suction strainer mounting ring.
- the gaskets must be clean and lightly covered with oil.
- Make sure all equipment connections are clear of plastic caps and rags.
- the piping system is to be clean and free of any moisture.



The HRP-pumps have undergone a short mechanical test run at ambient temperature with **refrigerant machine oil**, FUCHS Reniso synth 68, in the factory. If the pump is to be used in systems where contamination with this oil is not allowed, i.e. in cases with ester oil in the system, the residual oil must be removed and the pump cleaned by use of solvents.

8.2 MOUNTING INSTRUCTIONS

In order to drain the refrigerant pump for maintenance and cleaning of the suction strainer without completely dismantling it, sufficiently long threaded rods are required for suspended installation.



It is recommended to make them at least 180 mm long in order to ensure sufficient space for replacing the pointed screen.

A clearance of at least 95 mm must be provided below the refrigerant pump to allow the refrigerant pump to be lowered and an EA10 valve for oil drainage to be fitted if necessary.

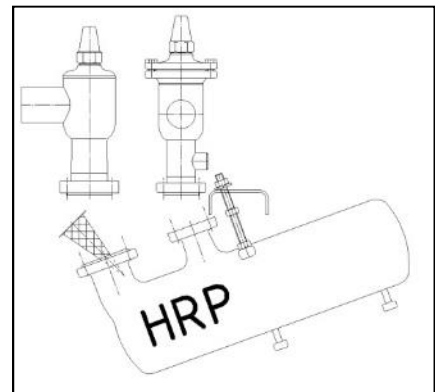

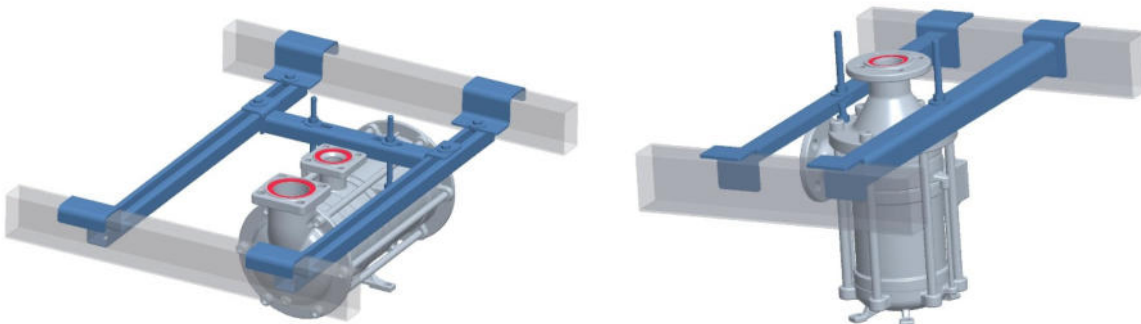

When HRP pumps are foot-mounted, the pump must be installed stress free to the base frame and the piping system. Special attention must be paid to the expected pipe contraction at low temperatures.

A hanging installation of the pump is to be preferred!

Advantages of the top mounting:

- A drip tray can be easily positioned and cleaned
- Thermal stress stress, caused by varying temperatures, is reduced.

For inspection and cleaning of the suction strainer it is sufficient to remove the screws of the flanges, loosen the nuts of the threaded rods and lower the refrigerant pump to the suction side.

It is important vertical pumps HRP3232 are aligned vertically, whereas the horizontal pumps HRP5040 to HRP10080 are horizontally aligned.

For pump arrangement see for instance fig. 6a, 6b and 6c.

Flange Alignment

Make sure the pump connection flange (grooves and tongues) are properly aligned. Do not use the flange bolts to align or "stretch" the pipe. Using flange bolts to pull together a too large gap will cause undue stress or distort the pump or the flange.

Do not use the mounting bolts to pull down the pump on to the frame work, the cast iron mounting footpads can fracture. Prior to mounting the pump it should be aligned with holes, using chims and if necessary use longer threaded bars with counter nuts.

The required torque to tighten the flange screws properly are given in the following table.

Nut size	Required torque	Suction flange of	Delivery flange of
M12	85 Nm	HRP5040 HRP5050	HRP5040 HRP5050 HRP8050
M16	210 Nm	HRP3232 HRP8050 HRP10080	HRP3232 HRP10080

Table 4

8.3 PRIOR TO COMMISSIONING

- the refrigeration system must be pressure tested, vacuum tested and be fully charged with refrigerant.
- the suction- and discharge valves must be fully open
- the valves of the pressure differential control, if fitted, must be fully open
- the pressure differential switch, if fitted, must be set at a difference of at least 20 kPa above the system static height. (static height means "liquid column + pressure difference between cooler inlet and separator")
- a sufficient volume of refrigerant must be present in the separator or low pressure receiver for a minimum running time of approximately 2-3 minutes.
- the electrical control system including all safety controls must be pre-tested prior to starting the pump.
- Check the wiring for the correct rotation of the motor.

8.4 COMMISSIONING PROCEDURE

- check and record the pressures in the system
- if the pressure difference is smaller than expected, the pump may be rotating in the wrong direction. Check proper rotation by measuring phase sequence. If it is necessary, switch off electrical system, change over two connecting cables and test pressure difference again.
- Close the discharge valve until the pressure difference reaches a maximum value as per table 1 and set the flow switch accordingly.
- If you hear unusual, or unfamiliar sounds from the pump, switch off the pump immediately and investigate the cause.

When the pump operates normally, check after 2 hours, after 8 hours and later the pressure difference and note the measured values. **After a period of trouble free operation (1 to 2 weeks) you should inspect the conical filter for dirt and contamination. Depending on the degree of contamination the conical filter should be regularly inspected and cleaned at planned intervals.**

8.5 DURING NORMAL OPERATION



During normal operation the pump does not require specific maintenance, there is no need to refill or to change the oil.

The maximum pressure lowering rate in the separator should not exceed a value of 2K/Min!

It is strongly recommended that the following items are checked frequently:

- check all screw connections for tight fit and leak tightness
- check the conical suction filter for contamination
- check the pumpre-circulation pipework for oil contamination
- check the pressure differential of the pump
- check the bearing wear
- listen to the running sound of the pump. Crackling noise indicates oil contamination
- once a year, or as dictated by the classification rules, the pump operation, settings and all safety provisions should be checked.
- The date, time and results of each inspection should be recorded together with the serial number.

8.6 PUMP STANDSTILL (STAND-BY)



During periods of pump standstill, only one valve may be closed, preferably the suction valve. When the suction and discharge valves are closed at the same time, trapping cold liquid in the pump, the pressure will increase rapidly, as the liquid warms up, to an unacceptable high value. This increase in pressure can very quickly damage the pump.

If there is oil contamination during standstill of the pump, the oil must be drained from the pump before restarting the pump; otherwise a malfunction may occur which may lead to the failure of the pump.

9. SERVICE AND MAINTENANCE

9.1 REMOVING A PUMP

Follow all national and local safety requirements when removing the pump. Particular care must be taken of the following:

- Check the plant room layout and exit doors so you can evacuate the area quickly in case of an emergency.
- Seek assistance to handle and remove the pumps.
- Wear the correct protective safety clothing, as minimum use a safety goggles and gloves, in case of NH₃ have a safety gas mask within easy reach.



Isolate the pump by switching off and locking off the electrical supply and the electrical controls. Make sure reconnection is not possible.

A label should be fixed to control panel to indicate pumps are switched off and are being worked on.

Note the sequence of electrical connections and disconnect the wiring.



A trained engineer or suitable qualified electrician in accordance with electrical engineering regulations should carry out any work on electrical equipment or controls.

Before moving or tilting the pump e.g. to access or to clean the conical suction filter, the refrigerant must be dis-charged. It is recommended that the refrigerant is purged to the dry gas side of the surge drum via the pressure gauge valve at the base of the discharge valve. Hot water may be used on the outside of the pump to accelerate the boiling off of the liquid refrigerant.



Never use naked flame or open fire to warm up the pump.

When there is no liquid refrigerant left in the pump, carefully open the slotted screw plug on the suction housing (58) by ¼ turn to depressurise the pump. When there is no residual pressure inside the pump the flange bolts can be carefully unscrewed. Be aware of any trapped liquid or leaking valves seats.

9.2 SHIPPING OF THE PUMP



When a pump has to be returned to the supplier or the factory be sure the pump is free of refrigerant, dirt and oil. **The risk of damages to goods or the environment by leaking oil during transport is at the senders risk.**

When returning the pump it is important that full information is provided stating the reason and cause of failure.

Therefore, please fill out the pump checklist, available on our website, as much as possible.

Always return the conical suction filter, in actual condition as found when the pump was opened, with the pump.

Please see chapter 7 for proper lifting of the pump.

9.3 GENERAL ADVICE

9.3.1 COMPRESSOR OIL IN THE PUMP



When too much oil flows into the pump from the separator, the pump will not operate properly or may be damaged.

Oil prevents sufficient cooling of the bearings resulting in an unacceptable overheating of the pump. Only the built in thermistor provides adequate safety.

Oil can be drained through a WITT EA 10 GÜ/GB stop valve which can be installed in place of the lower 1/4"-screw plug in the suction or discharge chamber.

Prior to installing the EA 10 GÜ/GB you have to make sure that the metal gasket 38 (see sectional drawing, fig. 3) has been removed. The counter nut of the EA 10 GÜ/GB needs to be screwed down entirely to mount the valve. When the valve is screwed in you fix the EA GÜ/GB with the counter nut in the chosen position.

When the oil is to be drained while the pump housing is still under pressure, a quick closing action valve must be used in addition to the drain valve. Oil from the discharge can only be removed from the pump through the drain plug on the discharge side. At low temperatures when oil flow is slow the pump must be warmed up on the outside with warm water to lower the viscosity of the oil making it flow more easily. The oil return system from the surge drum should be checked or modified to prevent further oil contamination of the pump.

9.3.2 DAMAGED ROTOR CAN

You cannot automatically detect whether the rotor can is damaged or is leaking since the stator housing is de-signed at the same compressive strength. To find out whether refrigerant has penetrated into the stator housing loosen carefully the 1/4" screw plug on the motor cover (09).



Always wear personal protective safety clothes, especially safety glasses!

Use a leak detector or if NH₃ was used you will simply smell whether refrigerant is present in the transformer oil.

9.3.3 PUMP INTERCHANGEABILITY

The inlet and outlet connection flanges of the HRP 5040, HRP 5050, HRP 8050 and HRP 10080 pumps are of the same sizes and diameters as FAS-flanges. All flanges are of a square design and have four (4) bolt holes.

The inlet and outlet connecting flanges of the HRP 3232 up to 40 bar are round type, EN 1092-1/11, C/DN32/PN40 (former DIN 2635/2512).

All other flanges are specially made and are therefore always delivered with counter flanges.

If you want to replace WITT GP pump models with HRP pump models please contact your supplier for further information.

9.4 REPARING A PUMP



It is not recommended you open and repair the pump. Preferably send the pump for repairing to your supplier or to the factory, if required request a replacement pump.

Repairs should only use factory supplied assemblies and be fitted by specially WITT trained personnel.

During the training a repair manual will be supplied by the manufacturer.

9.5 WARNINGS

WITT-HRP-pumps are of the canned type. All rotating parts, including bearings and motor rotor are in direct contact with the refrigerant.

Any unusual running conditions other than stable operation will have an influence on moving parts particularly the bearings. Dirt, oil and large pressure fluctuations may shorten the lifetime.



WITT HRP pumps are for refrigeration systems only. Read these instructions completely before selecting, using, or servicing these pumps. Only knowledgeable, trained refrigeration mechanics should install, operate, or service these pumps.

Stated temperature and pressure limits should not be exceeded.

Special attention must be paid to the national rules concerning the available materials.

Pump should not be removed unless system has been evacuated to zero pressure.



All local rules to refrigeration systems, and electric control and installation systems must complied with.

10. TROUBLE SHOOTING

No.	symptom	Possible causes
1	pump makes scratching noise	<ul style="list-style-type: none"> - noise comes from outside - foreign material in pump - operation against a too high pressure – check the setting of your overflow valve (or whether there is sufficient flow to the evaporators) - in CO2 systems check whether the minimum flow line is fully open - gas in the pump (e.g. level below minimum level in the surge drum, conical filter is blocked, too fast reduction of the evaporating temperature) - impellers or intermediate pieces worn out - bearings worn out - rotor in contact with can
2	capacity too low (valves on pump open)	<ul style="list-style-type: none"> - direction of rotation wrong - stop valves behind the pumps closed - too much gas in liquid (e.g. liquid level in separator too low, conical filter blocked, pump operates against a too high pressure) - valves on cooler closed - regulating valve not opened far enough - overflow valve pressure set too low - contamination is blocking the piping system - non return valve of an other pump leaks - dirt in the coolers - power supply not right, working on only 2 phases - impellers worn out - oil in pump at low temperature - wrong pump selection (not sufficient delivery head)
3	switched off on pressure difference control	<ul style="list-style-type: none"> - see number 2 - set value of pressure control not right - hand control valves in system opened too much - too quick start up or capacity steps of compressor(s) - too quick switch off of big capacities
	switched off on flow switch	<ul style="list-style-type: none"> - see number 2 - set value of flow switch not right - suction side or discharge side closed - too quick start up or capacity steps of compressor(s) - too quick switch off of big capacities
5	switched off by too high temperature	<ul style="list-style-type: none"> - Too much oil in the pump - Pump too warm (e.g. not sufficient cool down time right after installation, switching too much on/off, no minimum still-stand period (chap. 6.5)) - bearing filter (92) blocked
6	switched off by too high power consumption	<ul style="list-style-type: none"> - Too much viscous oil (at low temperatures) - Contamination with dirt, foreign material - Internal damages
7	life time of bearings too short	<ul style="list-style-type: none"> - too much gas in the pump, see above points - reverse flow through the pump (e.g. no or leaking check valve behind the pump, incorrect installed vent- or minimum flow lines, see chapter 6.4) - too much dirt in system
8	Motor protection/fuses trip the pump	<ul style="list-style-type: none"> - Moisture in the terminal box: check the connections and seal the terminal box - Pump is blocked (see above)

ANNEX

Steuerung 1: Pumpenstart nach Stillstand
Control 1: pump start after stand-still

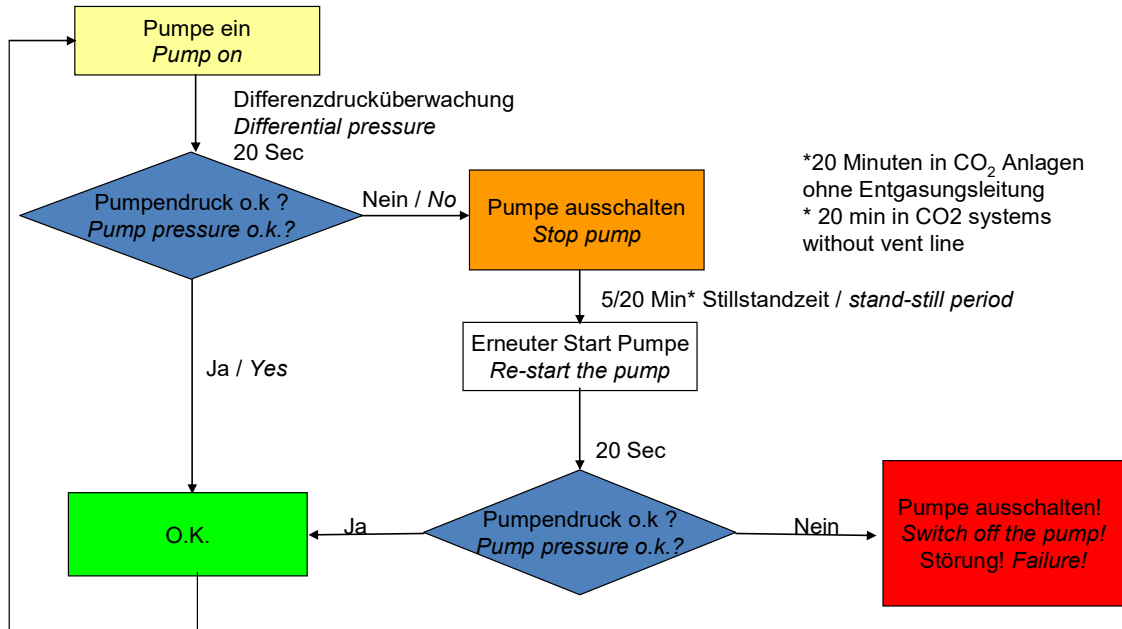

Recommendations for the control of HRP pumps

Steuerung 2 + 3: Betriebszustand (pro Pumpe)
Control 2 + 3: operation (for each pump)

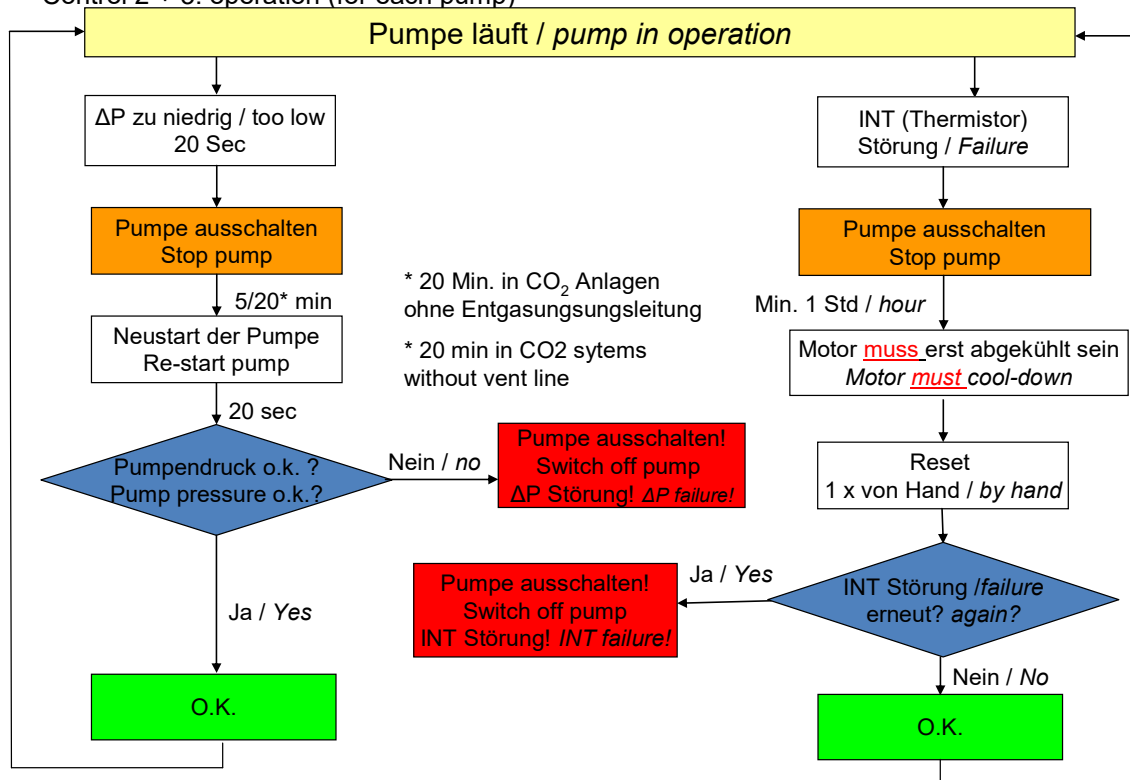

Steuerung 4: Betrieb mit 2 oder mehr Pumpen
 Control 4: operation with 2 or more pumps

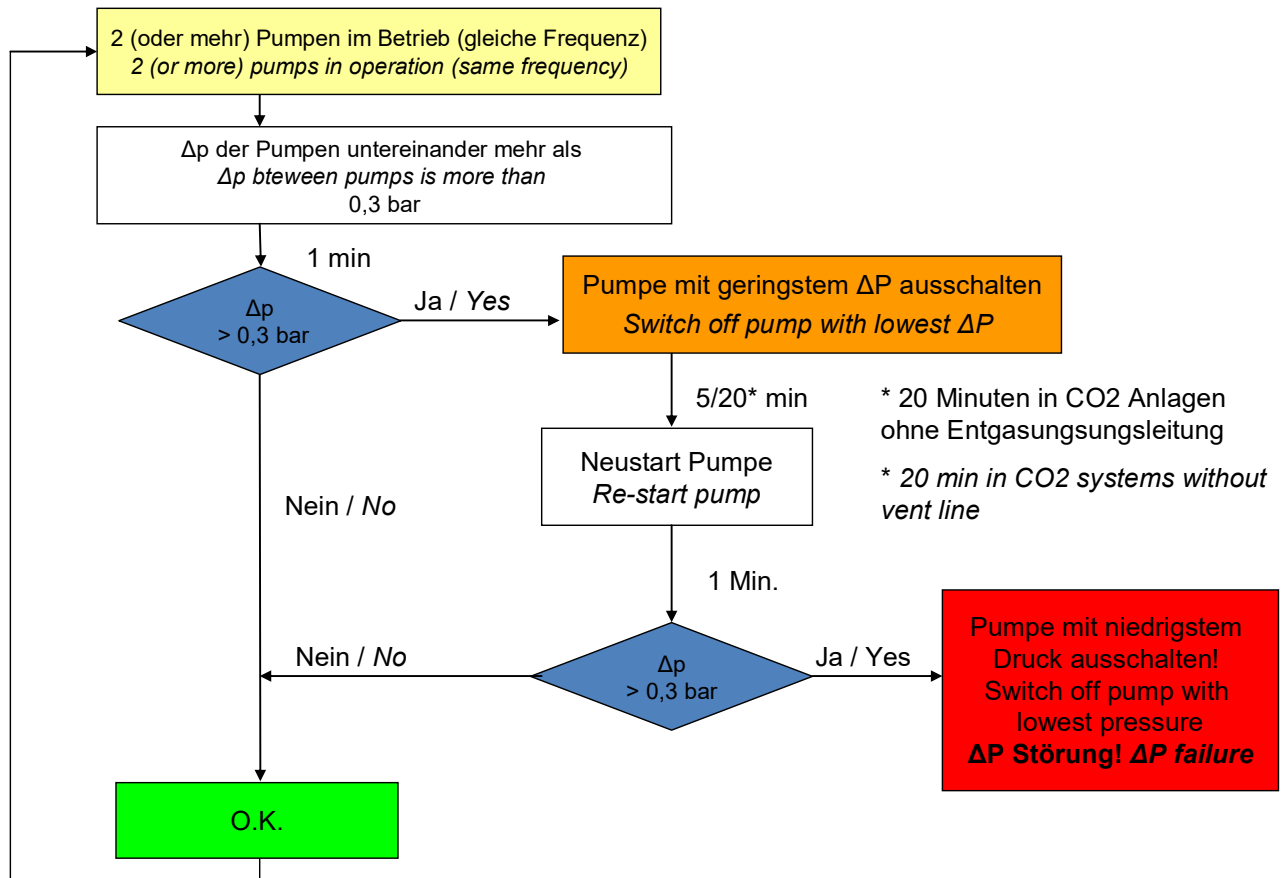

Possible causes ΔP failure

- Pump gets too much gas
- Pump contaminated
- Pump damaged

Steuerung 5: Betriebssituation, gilt für alle Pumpen
 Control 5: operating condition, for all pumps

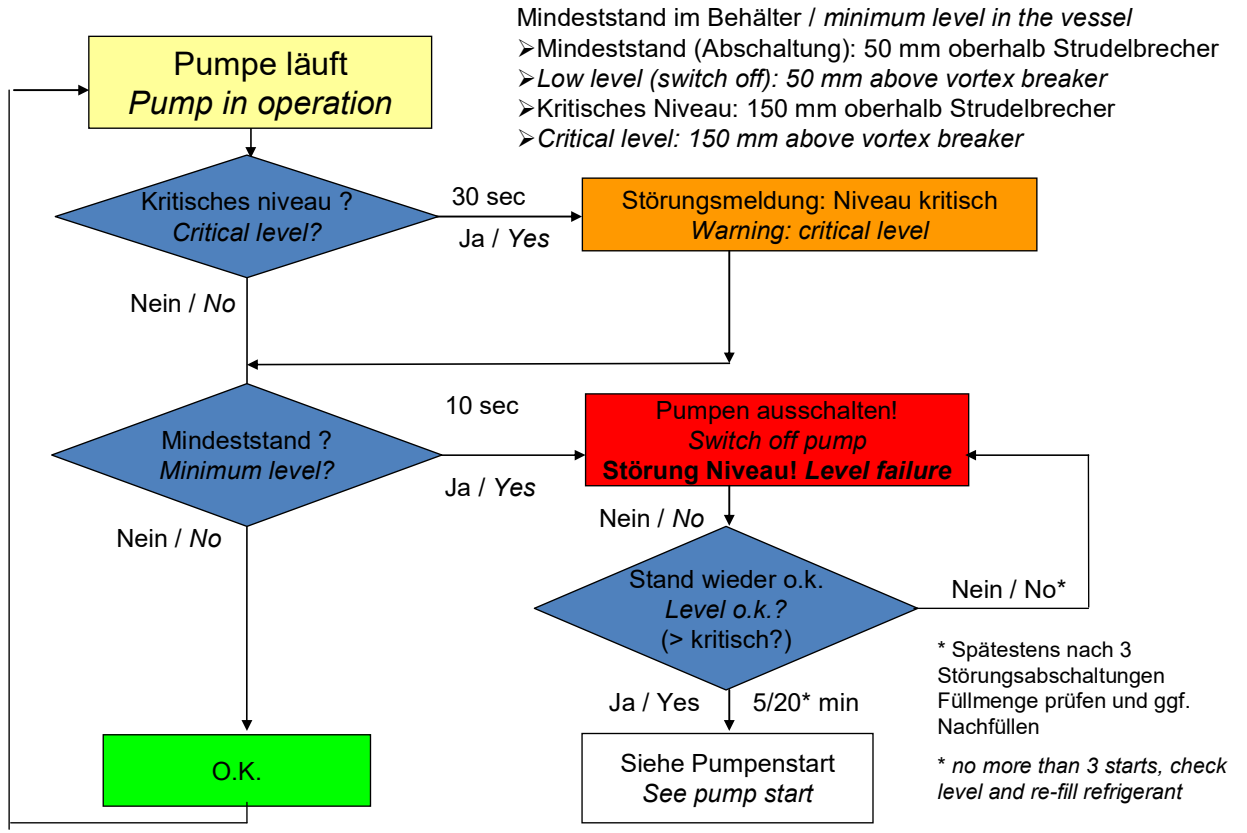

Possible causes ΔP failure

- Pump gets too much gas
- Pump contaminated
- Pump damaged

Frequency converters

Settings:

- Frequency for each pump must be the same
- Steep start ramp (1 - 2 sec), so the check valve behind the pump can open fast enough. The start-ramp in CO2 systems with minimum flow line right in front of the check valve can be increased to 10 sec to allow for a soft start
- Minimum 40 Hz, maximum 60 Hz
- Select current of the frequency converter as high as possible (less heat development in the pump)

Typischer Verlauf von Anlagen mit mehreren Pumpen und Frequenzumrichter
Typical trend of systems with multiple pumps and frequency control

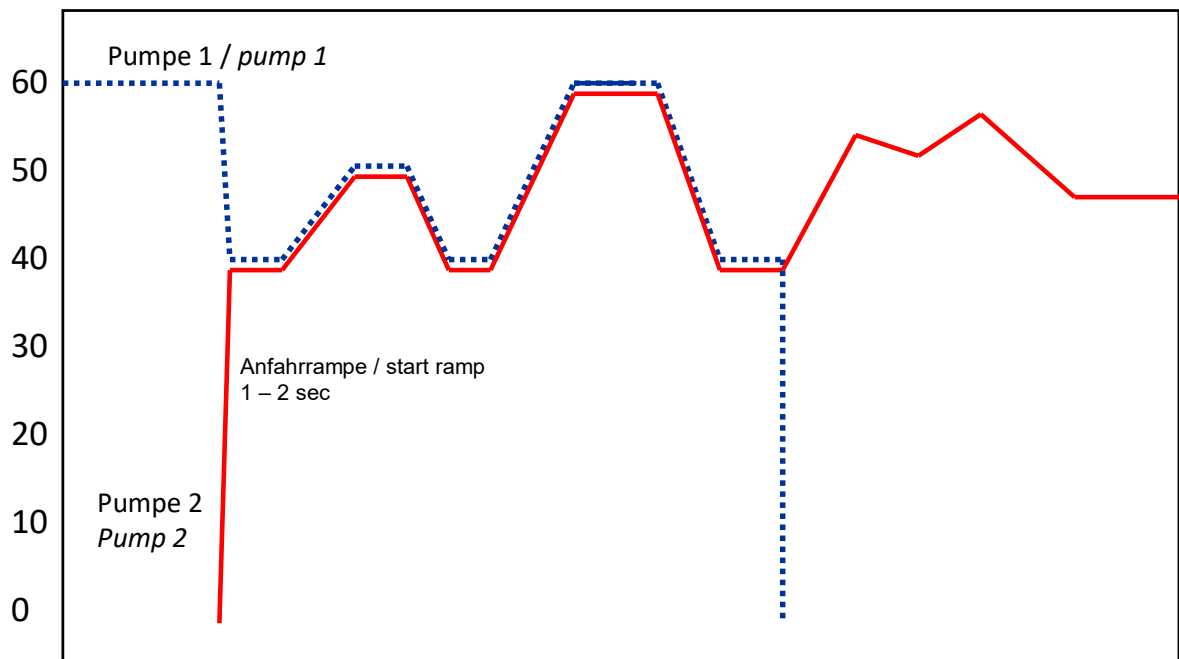

Pumpe nach dem Einschalten mindestens 5 min. im Betrieb lassen
Keep pump running for about 5 min. after starting



TH.WITT
Kältemaschinenfabrik
GmbH

Lukasstraße 32, 52070 Aachen, Germany
Tel. +49 241 18208-0
sales@th-witt.com

www.th-witt.com