

HS8A with Close-Coupled ST050 Strainer

INTRODUCTION

This heavy-duty HS8 refrigeration solenoid valve is compact and pilot-operated. It is now more dirt resistant, erosion resistant, and corrosion resistant than other similar refrigerant valves. A dirt controlling Teflon piston seal helps prevent sticking. The valve body has improved, erosion resistant flow passages. The HS8 is used to provide on-off control of refrigerant flow. When the coil is energized, a pressure difference across the piston opens the valve seat. When the coil is de-energized, a spring closes the main Teflon seat to stop all flow.

APPLICATIONS

The HS8 is ideal as a liquid line solenoid valve. While primarily for ammonia, this valve is also suitable for R22, R134a, CO₂ and other compatible refrigerants. The most common use of this valve is to control flow to: expansion devices, recirculating liquid overfeed evaporators, hot gas defrost, and small capacity evaporator suction. In addition, the HS8 makes an ideal noncondensable gas (air) purge point solenoid valve, and is recommended for use with Hansen AUTO-PURGER.

MAXIMUM RATINGS, AMMONIA

Liquid, Receiver Pressure: 110 Tons (387 kW)

Recirculation, 4 to 1: 36 Tons (127 kW)

Hot Gas: 10 Tons (35 kW)

Suction: 5.0 Tons (18 kW)

Flow Factor: Cv = 3.3 (2.9 Kv)

Specifications, Applications, Service Instructions & Parts

**HS8A & HS8W
SOLENOID VALVE
1/2" (13mm) PORT**

**3/8" thru 3/4"
FPT, SW, WN, ODS
for refrigerants**



KEY FEATURES

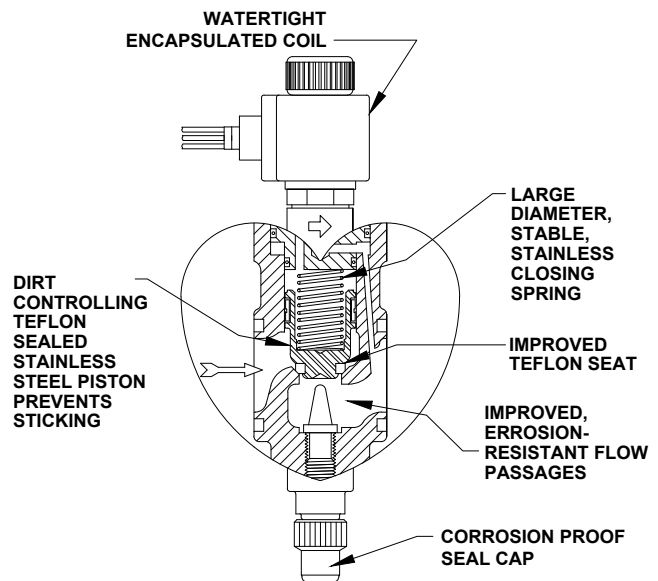

ADDITIONAL FEATURES

Low-wattage coil

300 psi (20 bar) MOPD, 500 psi (34 bar) for CO₂

Teflon main & pilot seats

Close-couples to ST050 (100 mesh) strainer or

HS8W integral strainer

Heavy-duty construction

CSA certified status

Wireless pilot lights (see page 2)

Replaceable Seat (HS8W)

MATERIAL SPECIFICATIONS

Body: HS8A - Cast ductile iron, corrosion-resistant coated
 HS8W - Cast Steel, ASTM 32, grade LCB, painted
 Bonnet Cartridge: Steel, plated
 Piston: Stainless steel, Teflon seal
 Plunger: Stainless steel
 Pilot Orifice: Stainless Steel
 Seats: Teflon, pilot and main
 Valve Seats: HS8A - Integral, Ductile Iron
 HS8W - Replaceable 303 Stainless steel
 MOPD: 300 psi (20 bar) AC coils only
 500 psi (34 bar) available
 Safe Working Pressure: 400 psig (28 bar)
 600 psig (42 bar) for CO2
 Operating Temperature: -60°F to +240°F (-50°C to +115°C)

ELECTRICAL

The coil draws 16 watts and will operate properly between 85% and 110% of rated voltage (24V coil draws 19 watts). Standard coil connection is a 1/2" fitting (NPSM) for conduit, with two 18" wire leads and ground wire. Coils with DIN plug or 1/2" NPSM quick disconnect plug are available. Contact the factory. All coils are totally encapsulated and meet NEMA 3R (rainproof) and NEMA 4 (splash proof, approx. IP65) requirements. The coil should only be energized while on the solenoid tube. Otherwise, immediate coil burnout may occur. To avoid bending the solenoid tube, remove the coil from valve before connecting any electrical conduit. Pilot lights are available.

COIL OPTIONS



Voltage	Frequency (Hertz)	Inrush Amps	Holding Amps	Resistance at Room Temperature (Ohms)
115VAC	60	0.73	0.24	56± 6
	50	0.93	0.31	
208/230VAC	60 (208V)	0.32	0.11	226± 23
	60 (240V)	0.41	0.14	
	50 (230V)	0.47	0.16	
24VAC	60	3.42	1.14	2± .2
	50	4.56	1.52	
24VDC	DC	1.2	1.2	20± 2

OPTIONAL BEACON PILOT LIGHTS

Pilot Light Kit includes Beacon pilot light, knob and o-ring.
 A/C Coils Only.

Beacon Pilot Light Kits	
Color	Part No.
Red	70-1100
Amber	70-1101
Green	70-1102



INSTALLATION

Protect the interior of the valve from dirt before and during installation. A close-coupled inlet strainer is normally installed and recommended. Allow 2.25" (57 mm) above the valve for coil removal and 3" (76 mm) below the strainer for screen removal. The arrow on the valve body must point in the direction of system flow. If a pressure reversal can occur use a check valve on the outlet side of the HS8A. The check valve can be close coupled directly to the HS8A outlet. For proper flange gasket sealing, care must be taken when threading or welding to assure flanges are parallel to each other and perpendicular to pipe. Also, gaskets should be lightly oiled and all bolts must be tightened evenly. During welding, the manual opening stem should be opened upward several turns to protect the Teflon seat from weld heat.

INSTALLATION DIMENSIONS

INCHES (MILLIMETERS)

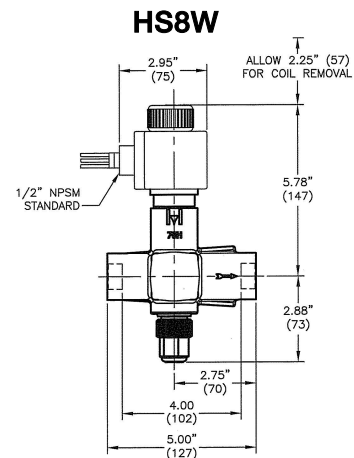
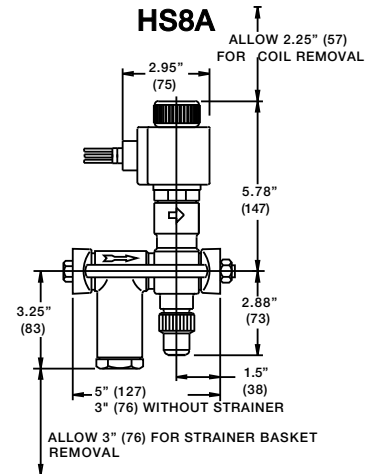

HS8W TOP VIEW

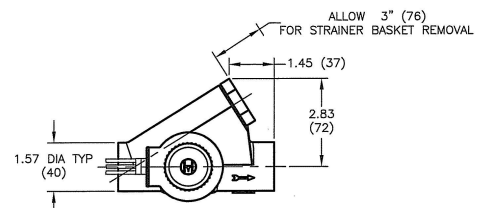

PARTS LIST

Item	Description	Qty	Part No.
1a	Coil Kit (115V) 1/2" Fitting w/leads Coil Kit	1	70-1085
1b	(208/230V) 1/2" Fitting w/leads Coil Kit	1	70-1086
1c	(24V) 1/2" Fitting w/leads Coil Kit (Other Voltages / Connections)	1	70-1087
	Coil Kit (Other Voltages / Connections)		FACTORY
	<i>Above kits consist of:</i>		
1	Bare Coil	1	
2	Coil Knob	1	
3	Coil O-Ring	1	
	Solenoid Tube/Plunger Kit	1	70-1059
	<i>Above kit consists of:</i>		
5	Plunger	1	
6	Solenoid Tube	1	
7	Solenoid Tube O-Ring	1	
8	Tube Screws	4	
2	Coil Knob	1	
3	Coil O-ring	1	
	Gasket Kit	1	70-1005
	<i>Above kit consists of:</i>		
7	Solenoid Tube O-Ring	1	
9	Upper Body O-Ring	1	
10	Lower Body O-Ring	1	
11	Flange Gasket Stem	3	
12	O-Ring Packing	1	
13	Packing	1	
14	Seal Cap O-Ring	1	
19	Packing Washer	1	
20	Packing Nut	1	
31	Seat O-Ring	1	
3	Coil O-Ring	1	
	Bonnet Cartridge Kit	1	70-1001
	<i>Above kit consists of:</i>		
15	Cartridge Assembly	1	
	Gasket Kit	1	
	Solenoid Tube/Plunger Kit	1	
	Piston Assembly Kit	1	70-1002
	<i>Above kit consists of:</i>		
16	Piston Assembly	1	
17	Closing Spring	1	
	Gasket Kit	1	
	Seat Kit (HS8W Only)	1	70-1302
	<i>Above kit consists of:</i>		
30	Seat Ring	1	
	Removal Tool	1	
	Seal Cap Kit	1	70-1075
	<i>Above kit consists of:</i>		
21	Seal Cap	1	
14	Seal Cap O-Ring	1	
	Strainer Screen Kit	1	78-1001
	<i>Above kit consists of:</i>		
22	Screen Assembly, 100 mesh	1	
23	Strainer Cap Gasket	1	
	Bolt and Nut Kit		
	For HS8A less Strainer (a)		78-1006
	For HS8A with Strainer (b)		78-1007
	<i>Above kits consist of:</i>		
25	Nut, 7/16-14	2	
26a	Bolt, 7/16-14x3 3/4	2	
26b	Bolt, 7/16-14x5 1/2	2	
18	Stem	1	
24	Strainer Cap	1	
27	Body	1	
29	Flanges	2	

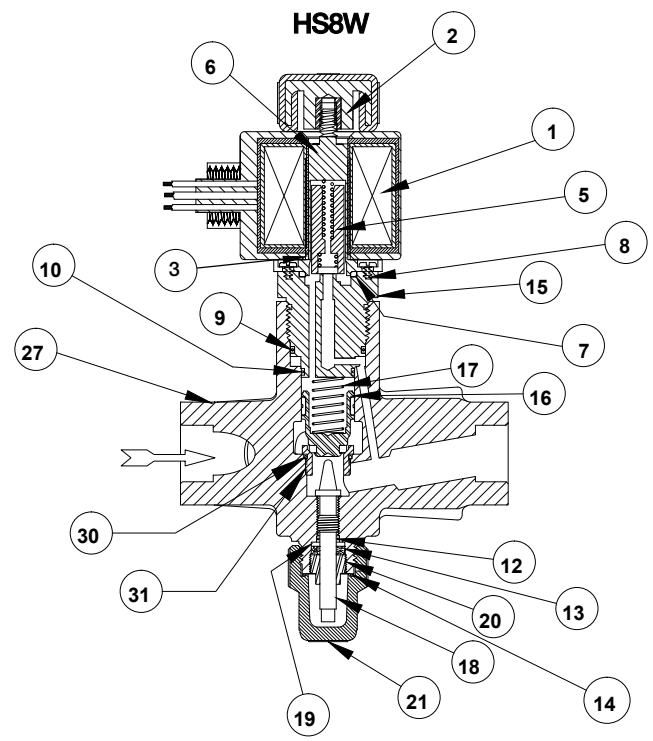
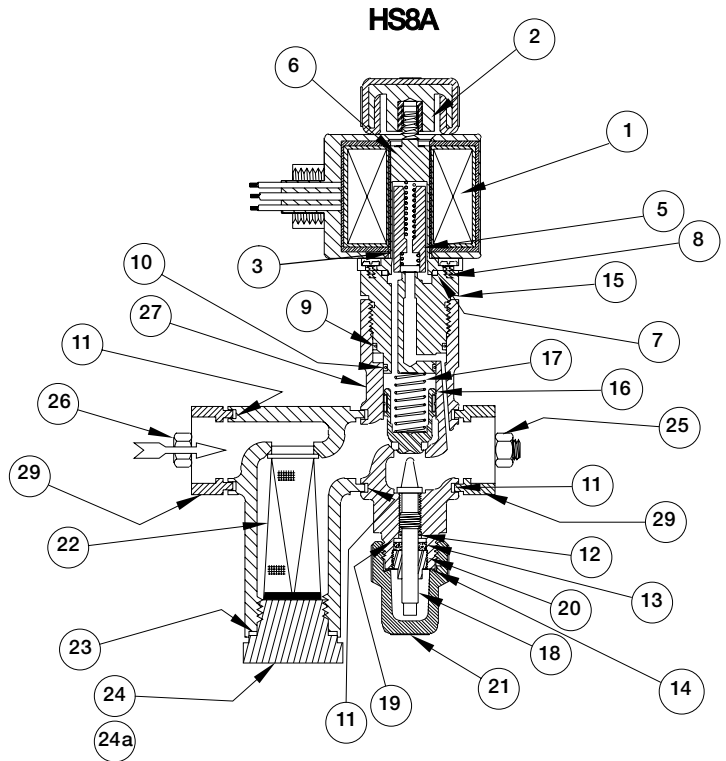

HS8W TOP VIEW

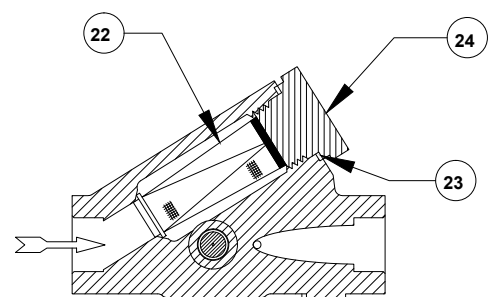

SERVICE AND MAINTENANCE

Failure to open: Wrong coil voltage; low line voltage; electric controlling device is not switching; coil is burned-out; inlet/outlet pressure differential is too high; piston or solenoid coil plunger is jammed closed with dirt.

Failure to close: Electric controlling device is not switching; manual-opening stem is turned in; piston or solenoid coil plunger is jammed open by dirt; damage or dirt at main valve seat or pilot valve seat.

Before opening the valve for service, be sure it is isolated from the system and all refrigerant is removed. Disconnect electrical power from coil. Remove the coils by unscrewing the coil knob. To remove internal parts, use a large wrench to slowly unscrew the bonnet cartridge (15), proceeding cautiously to detect any remaining refrigerant inside the valve. Then, remove the closing spring (17) and piston (16). Check for dirt on the piston (16), Teflon piston seal, and seat. Clean and reinstall or install new parts. Check the upper (9) and lower (10) body O-rings and replace if necessary. Use refrigerant oil or grease when installing the O-rings.

To check the pilot section of the valve, first loosen the four solenoid tube screws (8). Then, break the seal between the solenoid tube (6) and bonnet cartridge (15), being careful to avoid any refrigerant which may remain. Check the face of the Teflon seat in the plunger (5), the plunger spring, and the pilot seat orifice on the bonnet cartridge (15). Clean or replace parts as necessary. The pilot seat is integral with the bonnet cartridge. Install a new solenoid tube gasket (7) and oil lightly. Reassemble the bonnet cartridge (15) to the valve body (27), using 75 ft-lbs (102 N-m) torque to tighten the secondary, metal, knife-edge seal. Carefully check the valve for leaks before restoring to service.

CAUTION

Hansen valves are for refrigeration systems only. These instructions must be read completely and understood before selecting, using, or servicing these valves. Only knowledgeable, trained refrigeration technicians should install, operate, or service these valves. Stated temperature and pressure limits should not be exceeded. Bonnets, solenoid tubes, etc., should not be removed from valves unless the system has been evacuated to zero pressure. See also Safety Precautions in the current List Price Bulletin and the Safety Precautions sheet supplied with product. Escaping refrigerant can cause injury, especially to the eyes and lungs.

WARRANTY

All Hansen products, except electronics, are guaranteed against defective materials or workmanship for one year F.O.B. factory. Electronics are guaranteed against defective materials or workmanship for 90 days F.O.B. factory. No consequential damages or field labor is included.

ORDERING INFORMATION

Connection Style & Sizes Inches (Millimeters)			
FPT, SW, WN			ODS
STYLE	STD	ALSO	STD
HS8A	1/2" (13)	3/4" (20) 3/8" (10)	5/8" (16)
HS8W	1/2" (13)	3/4" (20) 1" (25) BW	5/8" (16) 7/8" (22) 1-1/8" (28)

FPT: Female Pipe Thread (American National Standard)

SW: Socket Weld to accommodate American and API pipe

WN: Weld Neck to match American pipe

ODS: Outside Diameter Sweat, for American copper tubes

Standard encapsulated solenoid coil is included for 50/60Hz 208/230, 115, or 24 volts; other voltages offered. Standard coil connection is a 1/2" fitting (NPSM). Coils with DIN plug or 1/2" NPSM quick disconnect plug are available; please specify when ordering. Pilot lights are also available.

TO ORDER

Specify type, connection type and size, volts, and strainer if required. Unless otherwise specified, standard coil with 1/2" connection will be supplied.

TYPICAL SPECIFICATIONS

"Refrigerant solenoid valves shall have encapsulated, watertight coils, Teflon seats, steel or ductile iron bodies, spring closing pilot and main valve seats, and be suitable for a safe working pressure of 400 psig (28 bar), as manufactured by Hansen Technologies Corporation or approved equal."



Hansen Technologies Corporation
681 Commerce Street

Burr Ridge, Illinois 60527 USA

Tel: 630.325.1565 Fax: 630.325.1572 Toll: 800.426.7368

Email: info@hantech.com Web: www.hantech.com

© 2021 Hansen Technologies Corporation