



SEE-LEVEL™ H1100-R

INTRODUCTION

Hansen SEE-LEVEL™ liquid indicators provide simple indication of true liquid levels in industrial and commercial refrigeration systems. When liquid is present the distinctive reflex lens appears dark; when vapor is present, the lens is light. The long universal housing provides adequate length for ease of welding as well as insulation clearance for low temperature applications. The optional frost shield facilitates clear viewing of liquid level under frosting conditions.

APPLICATION

SEE-LEVEL™ liquid indicators are suitable for ammonia, R22, R134a, CO2 and other approved refrigerants. Typical uses include: refrigerant receivers, level columns, accumulators, intercoolers, suction lines, oil lines, and liquid lines.

MATERIAL SPECIFICATIONS

Housing: Steel, ASME SA36 (ASTM A36), traceable, zinc chromate plated

Lens: Soda lime glass, fused in steel retainer ring

Retainer ring: Cold rolled steel (ASTM A108), zinc chromate plated

O-Ring/Pressure Gasket: Neoprene

Retainer Rotation Gasket: Red fiber

Frost Shield: Lucite, 2" (51 mm) long (4" optional)

Shield O-Ring: Buna-N

Safe Working Pressure: 600 psig (41 bar)

Operating Temperature: -60°F to +250°F
(-51°C to +121°C)

Specifications, Applications, Service Instructions & Parts

**SEE-LEVEL™
REFRIGERANT
LIQUID INDICATORS**

**ASME SA36
Housing Material**



ORDERING INFORMATION

CAT NO REFLEX LENS	CAT NO CLEAR LENS	DESCRIPTION	
H1100-R	H1100		Standard SEE-LEVEL™
H1100-RN	H1100-N		With Frost Shield
H1100C-R	H1100C		With Saddle Milled Housing
H1100C-RN	H1100C-N		With Saddle Milled Housing & Frost Shield

Shipping weight: 2 lbs.

ORDERING INFORMATION

Specify catalog number, and whether material certificate is required. For extended frost shield, order standard SEE-LEVEL™ plus p/n 77-1044.

ADVANTAGES

Hansen SEE-LEVEL™ housings meet the material requirements of ASME for direct welding to vessels, receivers, level columns or liquid lines. Furthermore, each is marked for material traceability; certifications are available upon request. The SEE-LEVEL™ has a large diameter reflex lens for easy viewing. Clear lens is also available. Frost shield length is suitable for temperatures down to -60°F (-50°C). Standard housing can be welded (fillet weld) into a 1.94"/2" diameter opening or 1½" socket weld fitting, or butt welded to a 1½" pipe (Schedule 80). The scarfed (saddle milled) housing is available for simplified welding over a 1.5" (38 mm) hole, onto 2½", 3", or 4" pipe, such as for level columns or liquid lines.

INSTALLATION

Do not install lens or gaskets before welding. Locate the SEE-LEVEL™ in an accessible area away from the movement of material and equipment. To prevent distortion of housing and protect threads from welding sparks and damage, leave retainer ring (less glass and gaskets) in housing during welding. Welds should be annealed as necessary in accordance with good practice. Painting of welds is recommended for corrosion protection.

After welding, remove retainer ring and then insert (in order) neoprene gasket (o-ring for clear lens), reflex lens, install the reflex lens with the raised glass rings in contact with the fluid, and fiber gasket into housing. Lubricate threads and screw retainer ring into housing and tighten to 30 ft/lbs (41 Nm) torque. Before putting into service, all pipe weld connections and the lens should be tested for leaks at pressure levels called for in appropriate codes. Test for leaks before inserting the optional frost shield.

To install frost shield, lightly coat the frost shield o-ring with refrigerant oil. Press frost shield into housing while holding a pliable thin-walled plastic straw across the o-ring; this allows air to escape. Withdraw straw once frost shield is fully inserted into housing.

INSTALLATION DIMENSIONS

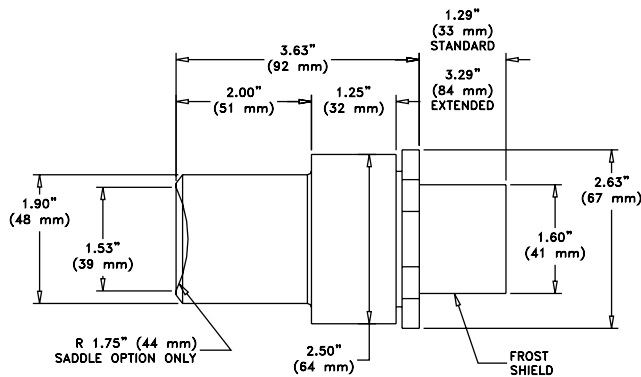

CAUTION

Hansen SEE-LEVEL™ liquid indicators are only for refrigeration systems. These instructions and related safety precautions must be read completely and understood before selecting, using or servicing these liquid indicators. Only knowledgeable, trained refrigeration mechanics should install or service these liquid indicators. Stated temperature and pressure limits should not be exceeded. Sight glass lenses should be inspected routinely and replaced if damaged.

See also safety precautions in current List Price Bulletin and Safety Precautions sheet supplied with product. Escaping refrigerant might cause personal injury, particularly to the eyes and lungs.

PARTS LIST

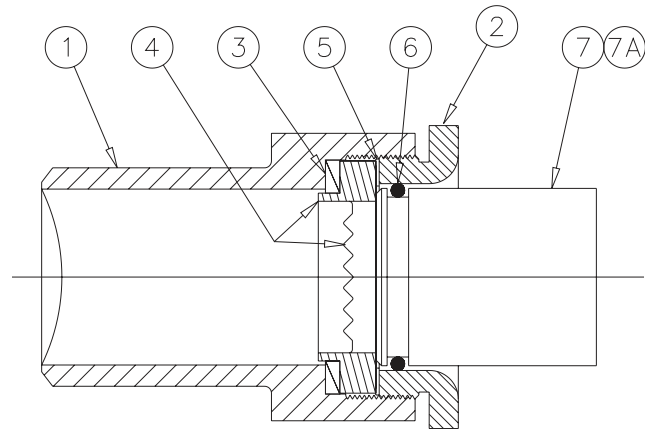

ITEM	DESCRIPTION	QTY	PART NO
1a	Standard Housing	1	77-0465
1b	Saddle Milled Housing	1	77-0475
2	Retainer Ring	1	77-0487
	Reflex Lens Kit Consists of:		77-1002
3a	Neoprene Gasket	1	77-0504
4a	Reflex Lens, Fused to Metal Ring	1	77-0792
5	Fiber Gasket	1	77-0505
	Clear Lens Kit Consists of:		77-1043
3b	O-Ring	1	75-0908
4b	Clear Lens, Fused to Metal Ring	1	77-2002
5	Fiber Gasket	1	77-0505
	Frost Shield Kit Consists of:		77-1003
6	O-Ring	1	77-0526
7	Frost Shield	1	77-0519
7a	Frost Shield Extended	1	77-1044

WARRANTY

All Hansen products, except electronics, are guaranteed against defective materials or workmanship for one year F.O.B. factory. Electronics are guaranteed against defective materials or workmanship for 90 days F.O.B. factory. No consequential damages or field labor is included.

TYPICAL SPECIFICATIONS

“Liquid indicators shall have steel housings made from code approved materials suitable for direct welding into ASME vessels, with glass reflex (or clear) lenses fused in steel retainer ring, and frost shields suitable for temperatures down to -60°F, and a maximum safe working pressure of 600 psig (40 bar). Liquid indicators shall be SEE-LEVEL™ as manufactured by Hansen Technologies Corporation or approved equal.”

HANSEN

Hansen Technologies Corporation
 400 Quadrangle Drive, Suite F
 Bolingbrook, Illinois 60440 USA
 Tel: 630.325.1565 Fax: 630.325.1572 Toll: 866.4HANSEN
 Email: sales@hantech.com Web: www.hantech.com
USA · Asia · Europe · India · Latin America · Middle East
 © 2010 Hansen Technologies Corporation